

# Safe Area Wash System

## DATA SHEET

### Description

The gas turbine compressor wash system is designed to clean gas turbine compressor blades in non-hazardous areas by using a high-pressure hot water jet, with a maximum pressure of 150 bar.

The unit is free standing and has a three phase 50 Hz or 60 Hz, 380 through 690 VAC, 4 kW motor driving high-pressure water pump.

There is also a water tank within the unit with an integrated 6 kW temperature controlled heating element. Wash System components are suitable for Safe Area only.



### Features

Static or wheeled portable versions

Non-hazardous or Safe Area application

Hot, high-pressure system

Stainless or mild steel cabinet versions

All wetted parts in passivated stainless steel

Self-contained

### Applications

- Gas turbines

### Technical data

#### Electrical information

Max. power consumption	6 kW
Voltage	380 through 690 VAC, 3 phase
Frequency	50/60 Hz
Motor power	4 kW/5.5 Hp
Heating element	6 kW
Water requirements	60 °C
Max. inlet temperature	
Min. inlet pressure	2 bar
Performance data maximum working pressure	150 bar
Maximum water flow rate	15 l/min
Maximum output temperature	70 °C
Sound pressure	85 dB (A)
All electric components	IP65 or above

# Dimensions

Typical Wash System General Arrangement Drawing (please see note\*)

WEIGHT, DRY = 90 Kg  
WEIGHT, WET = 160 Kg

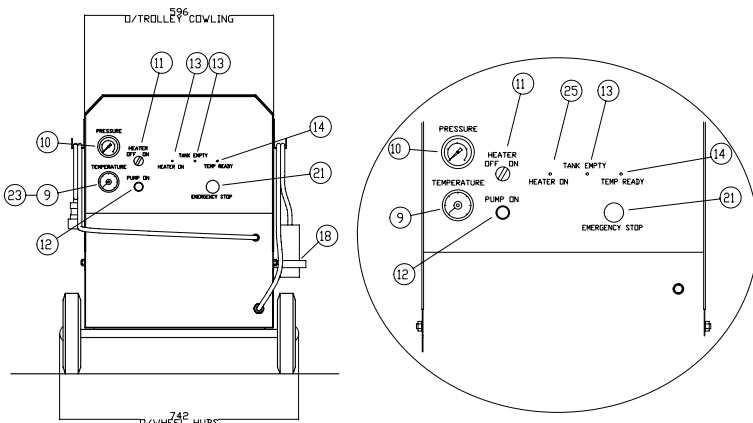
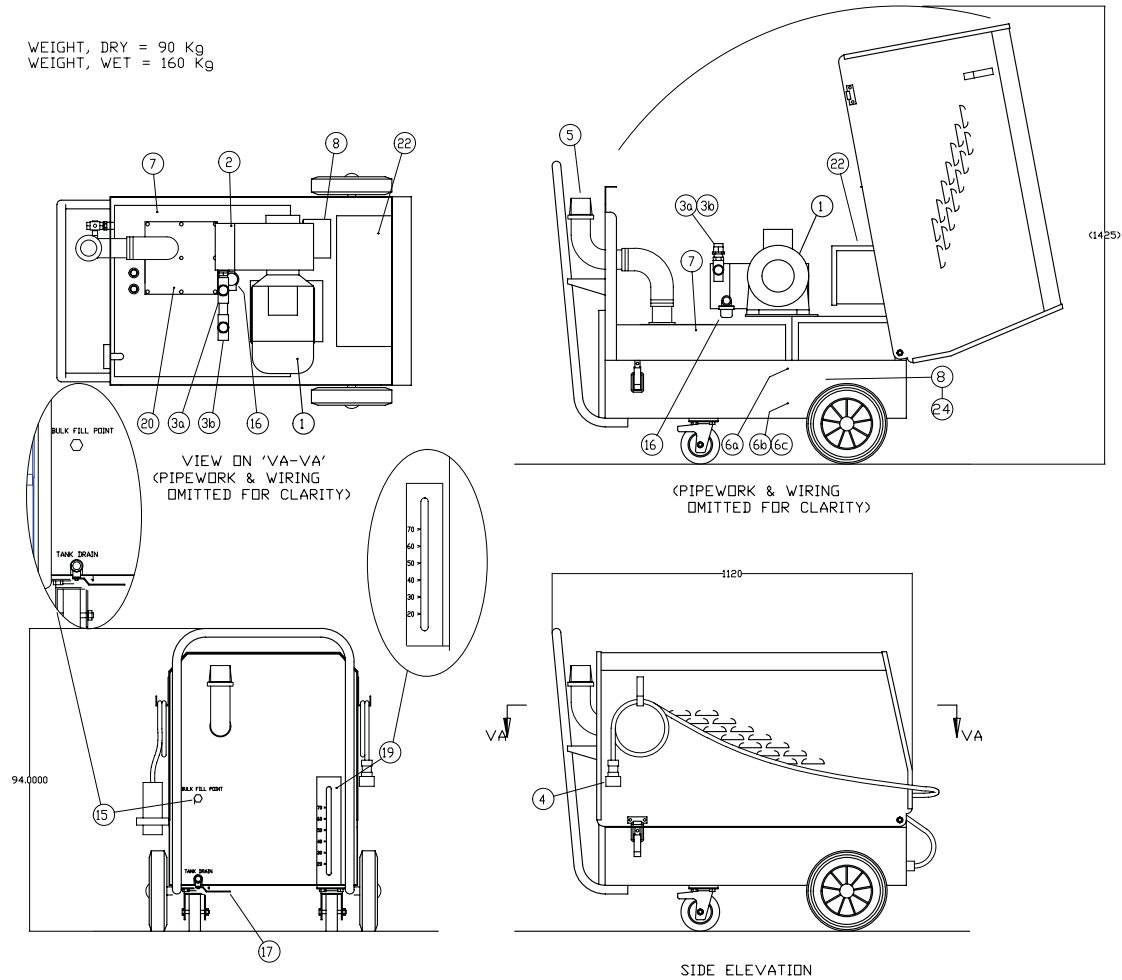

KEY COMPONENT LEGEND			
KEY No.	DESCRIPTION	SIZE	TAG No.
1.	MOTOR		XM15
2.	PUMP	23D.020	MULTI-PISTON XP6
3a.	PRESSURE CONTROL VALVE	1/2" NPT	40A002 PCV34
3b.	SAFETY VALVE	1/2" NPT	40A002 PSV57
4.	WASH FLUID OUTLET (HANSEN Q.R.)	1/2" HK SERIES	SOCKET & DUSTCAP FNC
5.	TANK FILLER WITH FILTER	76mm	FILTER-AB.68918 XF85
6a.	TANK 'LOW LEVEL SWITCH'		FLDAT SWITCH-RSF40 LS78A
6b.	TANK 'LOW LEVEL SWITCH'		FLDAT SWITCH-RSF40 LS78B
6c.	TANK 'LOW LEVEL SWITCH'		FLDAT SWITCH-RSF40 LS78D
7.	TANK (s.s.)	925x545x283	
8.	HEATING ELEMENT		RESISTIVE ELEMENT IH7A
9.	TEMPERATURE GAUGE		TI23
10.	PRESSURE GAUGE	9C.001; G1/4"	LIQUID FILLED PI56
11.	HEATER SWITCH (ON/OFF)		2 POS'N SWITCH HS77
12.	PUMP SWITCH (ON/OFF)		MOMENTARY PUSHBUTTON HS98
13.	TANK EMPTY INDICATOR		RED LED INDICATOR XL56
14.	TEMPERATURE READY INDICATOR		GREEN LED INDICATOR XL55
15.	TAP FILL POINT	3/8" BSPP FEMALE	JVC
16.	FILTER ELEMENT	78.002 - 50 MICRON	INLINE FILTER XF109
17.	DRAIN VALVE	3/8" NPT FEMALE	HV117
18.	ELECTRIC CONNECTION PLUG		
19.	TANK LEVEL GAUGE	1/2"	CLEAR TUBE LG7
20.	TANK INSPECTION COVER		
21.	EMERGENCY STOP BUTTON		MUSHROOM HD P/BUTTON HS97
22.	CONTROLS ENCLOSURE		
23.	TEMP. SWITCH (CONTROL)		TS78
24.	TEMP. SWITCH (CUT-OUT)	(PART OF HEATER)	BI-METALLIC STRIP TS80
25.	HEATER ON INDICATOR		RED LED INDICATOR

\* Note. Please ask manufacturer for the exact drawing against your order. Wash systems may vary in control and layout arrangements depending on the application.

