



Heinzmann GmbH & Co. KG

Engine & Turbine Controls

Am Haselbach 1
D-79677 Schönau (Schwarzwald)
Germany

Phone +49 7673 8208-0

Fax +49 7673 8208-188

E-mail info@heinzmann.com





www.heinzmann.com

V.A.T. No.: DE145551926

HEINZMANN®
Digital Electronic Speed Governors

Operating Instructions Hand Programmer

HP 03 - 03

 <p>Warning</p>	<p>Read this entire manual and all other publications appertaining to the work to be performed before installing, operating or servicing your equipment.</p> <p>Practice all plant and safety instructions and precautions.</p>
 <p>Danger</p>	<p>Failure to follow instructions may result in personal injury and/or damage to property.</p> <p>HEINZMANN will refuse all liability for injury or damage which results from not following instructions</p>
 <p>Danger! High Voltage</p>  <p>Danger</p>	<p>Please note before commissioning the installation:</p> <p>Before starting to install any equipment, the installation must have been switched dead!</p> <p>Be sure to use cable shieldings and power supply connections meeting the requirements of the <i>European Directive concerning EMI</i>.</p> <p>Check the functionality of the existing protection and monitoring systems.</p>
 <p>Danger</p>	<p>To prevent damages to the equipment and personal injuries, it is imperative that the following monitoring and protection systems have been installed:</p> <p>Overspeed protection acting independently of the speed governor</p> <p>Overtemperature protection</p> <p>HEINZMANN will refuse all liability for damage which results from missing or insufficiently working overspeed protection</p> <p>Generator installation will in addition require:</p> <p>Overcurrent protection</p> <p>Protection against faulty synchronization due to excessive frequency, voltage or phase differences</p> <p>Reverse power protection</p>
	<p>Overspeeding can be caused by:</p> <p>Failure of the voltage supply</p> <p>Failure of the actuator, the control unit or of any accessory device</p> <p>Sluggish and blocking linkage</p>



 Warning	<p>With electronically controlled injection (MVC) the following provisions must in addition be observed:</p> <p>With Common Rail systems, a separate mechanical flow limiter must be provided for every injector pipe.</p> <p>With Pump-Pipe-Nozzle (PPN) and Pump-Nozzle (PNE) systems, fuel delivery may be enabled only with the control piston of the magnetic valve moving. By this, fuel delivery to the injection nozzle will be inhibited should the control piston be blocked or jamming.</p>
 Warning	<p>Any examples, data and any other information contained in this manual are intended exclusively as instruction aids and should not be used in any particular application without independent testing and verification by the person making the application.</p>
 Danger	<p>Independent testing and verification are especially important in any application where malfunction might result in personal injury or damage to property.</p>
	<p>HEINZMANN make no warranties, express or implied, that the examples, data, or other information in this volume are free of error, that they are consistent with industry standards, or that they will meet the requirements for any particular application..</p>
	<p>HEINZMANN expressly disclaim the implied warranties of merchantability and of fitness for any particular purpose, even if HEINZMANN have been advised of a particular purpose and even if a particular purpose is indicated in the manual.</p>
	<p>HEINZMANN also disclaim all liability for direct, indirect, incidental or consequential damages that result from any use of the examples, data, or other information contained in this manual.</p>
	<p>HEINZMANN make no warranties for the conception and engineering of the technical installation as a whole. This is the responsibility of the user and of his planning staff and specialists. It is also their responsibility to verify whether the performance features of our devices will meet the intended purposes. The user is also responsible for correct commissioning of the whole installation.</p>

Table of Contents

	Page
1 Safety Instructions and Related Symbols.....	1
1.1 Basic Safety Measures for Normal Operation.....	2
1.2 G Basic Safety Measures for Servicing and Maintenance	2
1.3 V Before Putting an Installation into Service after Maintenance and Repair Works.....	3
2 Introduction	4
3 Operating and Display Elements	6
3.1 LC Display.....	6
3.2 Keypad.....	7
4 Operating Modes and Functions.....	8
4.1 Initialization.....	8
4.2 Programmer Mode.....	8
4.3 Measuring Window Mode	10
4.4 Function Selection Menu.....	11
4.4.1 Changing Over to Programmer Mode	12
4.4.2 Changing Over to Measurement Window Mode.....	13
4.4.3 Read Out Error Memory and Error Environment Data	13
4.4.4 Store Data in Control Unit	15
4.4.5 Clear Current Errors.....	15
4.4.6 Clear Error Memory.....	15
4.4.7 Clear Operating Data	17
4.4.8 Upload Parameter Data Set.....	17
4.4.9 Download Parameter Data Set.....	18
4.4.10 Using Parameter Masks/User Masks	19
4.4.11 Hand Programmer Settings and Device Information.....	20
4.4.12 Automatic Actuator Adjustment.....	21
4.4.13 Activate/De-activate Click Test.....	22
4.4.14 Reset Control Unit	23
4.5 Hand Programmer in PC Operating Mode	23
4.5.1 Programme in HP.....	24
4.5.2 Send All Data.....	24
4.5.3 Send Data of Selection.....	25
4.5.4 Get Data	25
4.5.5 Close	25

5 Technical Data	26
5.1 Specification	26
5.2 Device Dimensions	27
5.3 Connection Cables	27
5.3.1 Adapter Governor – Hand Programmer HP 03	27
5.3.2 Adapter Hand Programmer HP 03 – DC 1-03	28
5.3.3 Adapter Hand Programmer HP 03 – MVC	28
5.3.4 Adapter PC – Hand Programmer HP 03	29
6 Index of Figures	30
7 Index of Tables	31
8 Index	32
9 Order Specifications for Manuals	33

1 Safety Instructions and Related Symbols

This publication offers specific safety instructions, wherever necessary, to indicate inevitable residual risks when operating the engine. These residual risks imply dangers to

- persons
- product and engine
- environment.

The symbols used in this publication are in the first place intended to direct your attention to the safety instructions!



Warning

This symbol is to indicate that there may exist dangers to the engine, to the material and to the environment.



Danger

This symbol is to indicate that there may exist dangers to persons. (Danger to life, personal injury).



**Danger!
High
Voltage**

This symbol is to indicate that there exist particular dangers due to electrical high tension. (Mortal danger).



Note

This symbol does not refer to any safety instructions but offers important notes for better understanding the functions that are being discussed. They should at any rate be observed and practiced. The respective text is printed in italics.

The primary issue of these safety instructions is to prevent personal injuries!

Whenever some safety instruction is preceded by a warning triangle labelled “Danger” this is to indicate that it is not possible to definitely exclude the presence of danger to persons, engine, material and/or environment.

If, however, some safety instruction is preceded by the warning triangle labelled “Warning” this will indicate that danger of life or personal injury is not involved.

The symbols used in the text do not supersede the safety instructions. So please do not skip the respective texts but read them thoroughly!

In this publication the Table of Contents is preceded by diverse instructions that among other things serve to ensure safety of operation. It is absolutely imperative that these notes be read and understood before commissioning or servicing the installation.

1.1 Basic Safety Measures for Normal Operation

- The installation may be operated only by authorized persons who have been duly trained and who are fully acquainted with the operating instructions so that they are capable of working in accordance with these instructions.
- Before turning the installation on please verify and make sure that
 - only authorized personnel are present within the working range of the engine;
 - nobody will be in danger of suffering injuries by starting the engine.
- Before starting the engine always check the installation for visible damages and make sure it is not put into operation unless it is in perfect condition. On detecting any faults please inform your superior immediately!
- Before starting the engine remove any unnecessary material and/or objects from the working range of the installation/engine.
- Before starting the engine check and make sure that all safety devices are working properly!

1.2 Basic Safety Measures for Servicing and Maintenance

- Before performing any maintenance or repair work make sure the working area of the engine has been closed to unauthorized persons. Put on a sign warning that maintenance or repair work is being done.
- Before performing any maintenance or repair work switch off the master switch of the power supply and secure it by a padlock! The key must be kept by the person performing the maintenance and repair works.
- Before performing any maintenance and repair work make sure that all parts of engine to be touched have cooled down to ambient temperature and are dead!
- Refasten loose connections!
- Replace at once any damaged lines and/or cables!

- Keep the cabinet always closed. Access should be permitted only to authorized persons having a key or tools.
- Never use a water jet to clean cabinets or other casings of electric equipment!

1.3 Before Putting an Installation into Service after Maintenance and Repair Works

- Check on all slackened screw connections to have been retightened.
- Make sure the control linkage has been reattached and all cables have been reconnected.
- Make sure all safety devices of the installation are in perfect order and are working properly.

2 Introduction

The Hand Programmer HP 03-03 is a HEINZMANN diagnosis tool for configuring and visualizing input and output data of digital HEINZMANN Control Units. This diagnosis tool has been conceived as a support for work on test benches and for use in production, commissioning and maintenance or service work. The control devices will work independently of the Hand Programmer once the parameters have been suitably configured for the respective application and have been stored.

The general operation of the Hand Programmer is identical for all HEINZMANN Controls and does not depend on whether a diesel and/or gas engine speed control or a generator control or an electric motor control is being used. Additional menu items offer device specific indications that will appear only when the respective control unit has been selected.

The Hand Programmer is shipped with an access authorization conforming with the admissible software versions. Due to this authorization, the customer can access only his own control units, i.e., control units using his specific software version. Any attempt to establish communication with control devices of other HEINZMANN customers will be inhibited and produce an error message.

In addition, every Hand Programmer is given an identification number which is used by the control unit to keep a record of which diagnosis tool was used last for saving the data. By this, the actual data set in the control unit includes information on which group of persons may be held responsible for the adjustment of the parameters.

The parameters of all HEINZMANN control devices are subdivided into four groups:

- Configuration parameters defining the operating mode of the functions of the control unit,
- Measuring and calculation values providing measured and calculated data,
- Function parameters determining which functions of the control unit are to be active, and
- Parameters for characteristic curves and maps representing series of reference values and limit values.

Every parameter consists of a parameter number, a parameter name, its current value within a given value range, its respective measuring unit and an access level.

The Hand Programmer and the HEINZMANN Controls are based on a level oriented concept of access. Each parameter is associated with a fixed level in the control unit determining a criterion from which upward the parameter will be visible for the user of the diagnosis tool.

The different levels and their significations are described in the below Table 1:

Level	User	Access
1	End user	Indication of the most relevant operation data and error conditions. Modification of the control and engine data is not possible.
2	Plant manufacturer	Speeds, dynamics and performance can be adjusted within the permissible ranges.
3	Service	Except for certain engine parameters the majority of parameters can be modified.
4	Engine manufacturer	All control parameters are accessible.
5	Manufacturers of particular engines	Additional customer specific software modifications and expansions can be parameterized.
6	Manufacturer of control devices	Permits of modifying the functionality and configuration of inputs/ outputs.

Table 1: Access Level

The higher the level, the more parameters and hence control functions can be modified. When being shipped, the Hand Programmer is set to the maximum level that can be ordered by the customer. The programme will display only those parameters whose access level is not higher than this maximum level. Though the access level may be temporarily reduced via the Hand Programmer, it can never be set to a value higher than the fixedly set maximum value.

The control unit will accept any modifications of the parameter values, and after storing them temporarily in a volatile memory it will operate using the modified values immediately but for a few exceptions. After a reset, however, or on turning power off these data is bound to get lost unless it has been transferred to the control's permanent memory by an explicit storing procedure.

3 Operating and Display Elements

3.1 LC Display

The Hand Programmer HP 03-03 includes as a display element a backlit liquid crystal (LC) display of four lines with 20 characters each. Depending on the operating mode of the device, this display will offer the operator different types of information.

The three figures below show each an example of the different outputs of the display:

- in Programmer Mode; for this mode refer to section [↑ 4.2 Programmer Mode](#), configuration of the display as in Figure 1,
- in Measurement Window Mode; for this mode refer to section [↑ 4.3 Measuring Window Mode](#), configuration of the display as in Figure 2, and
- in Function Selection Mode; for this mode refer [↑ 4.4 Function Selection Menu](#), configuration of the display as in Figure 3.

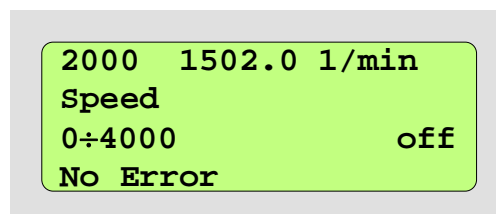

Figure 1: LCD in Programmer Mode

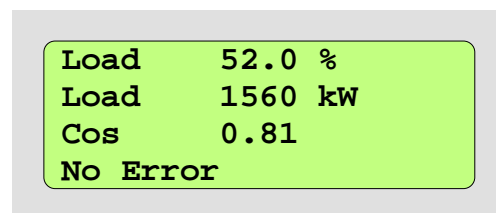

Figure 2: LCD in Measurement Window Mode

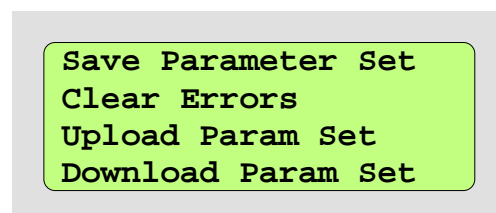

Figure 3: LCD in Function Selection Mode

3.2 Keypad

Manual operation of the Hand Programmer by the user is by means of the foil keyboard and its seven push keys. The keypad as a control panel is shown in Figure 4:

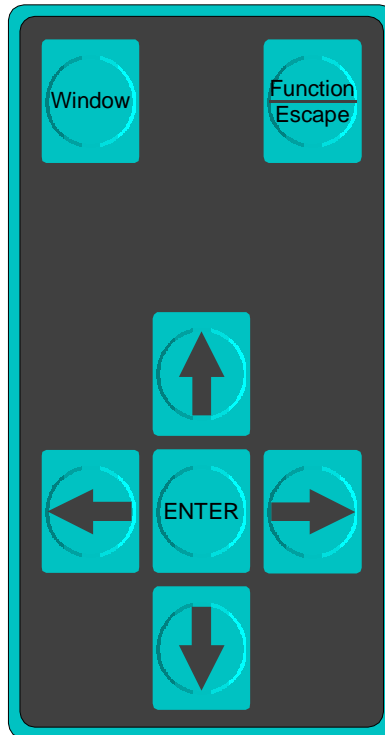

Figure 4: Keypad

Table 2 below describes the basic functions of the individual keys.





Keys	Function
	Moving to the next parameter list or parameter group (available exclusively in Programmer Mode)
	Calling the function selection menu or leaving the function menus or returning to the last standard operating mode
	Moving within parameter lists, function menus, etc., or for changing values when entering values
	Moving between characters/decimal places when entering values/passwords
	Selection/Acknowledgment

Table 2: Basic Key Functions

4 Operating Modes and Functions

4.1 Initialization

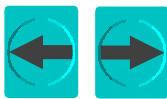
On being powered up, the Hand Programmer HP 03-03 will start operation by the initialization phase and by establishing communication with the connected HEINZMANN control unit. The display will in this phase show the address and phone number of the HEINZMANN Company. Then two indication windows are displayed with the permanently programmed maximum user level, the identification number and the serial number as well as the access masks

The initialization phase and the setup of communication will have been successful when in accordance with the specific level the first parameter of the connected control unit is being shown. The Hand Programmer is now in Programmer Mode and ready for operation (see also section [↑ 4.2 Programmer Mode](#)).

During initialization, it is checked by means of the access masks that have been set whether the diagnosis tool has been assigned the right of accessing the connected control unit, see also the chapter [↑ 2 Introduction](#). In case access should be denied the error message

“Access to this control unit is not allowed!”

is output by the display, and communication between the two devices is aborted.

If communication with the control unit cannot be established for any other reasons, the display will after initialization read

“No connection to control unit! Trying to reconnect.”

In this event, the device will try every second to establish communication with the control unit. This procedure is visualized by two arrows moving against each other in the fourth line of the display. In order to eliminate this problem the operator should check the plug connection and/or execute a reset of the control unit.

4.2 Programmer Mode

Besides the Measurement Window Mode the Programmer Mode is one of the Hand Programmer's two standard operating modes, see also section [↑ 4.3 Measuring Window Mode](#). Depending on the user level, it is in this operating mode that individual parameters can be displayed and adjusted as well as individual measuring or calculating values visualized.

Figure 5 shows the layout of the display in Programmer Mode.

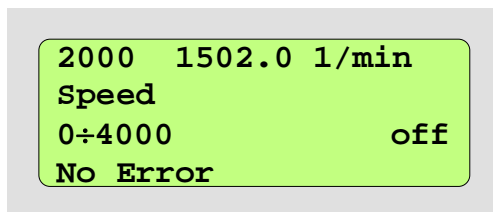











Figure 5: LCD in Programmer Mode

For every parameter/measurement, the parameter number, the current value and the measuring unit are output in the first line of the display. When a measurement or a calculating value is being shown, it will continuously be updated. The second line contains the parameter name, the third line the value range and, optionally, information concerning the user mask, (see also section [↑] 4.4.10 *Using Parameter Masks/User Masks*). The fourth line serves for indicating currently occurring errors. If several errors are active, the error indication will cyclically display the individual errors in turn. If currently no error has occurred, the text

“No Error”

is output in this line.

Table 3 below lists the operating options in Programmer Mode.

Action	Keys
Parameter indication: Show next/preceding parameter/measurement	 
Parameter indication: Activate direct parameter selection (first digit of parameter number is blinking)	
Parameter indication: Stop/continue updating the indicated value or edit the parameter being shown (last digit of parameter value is blinking)	
Input of parameter value/number: Moving between the decimal places	 
Input of parameter value/number: Increasing/decreasing the value of the blinking decimal place	 
Input of parameter value/number: Terminate without confirmation	





Action	Keys
Input of parameter value/number: Terminate with confirmation	
Parameter indication: Activation of the Function Selection Menu	
Parameter indication: Got to next parameter list (parameter shown last in list)	
Changing between parameter lists: Show parameter at end/beginning of list	 

Table 3: Operating Options in Programmer Mode

4.3 Measuring Window Mode

In dependence of the connected control unit, the Hand Programmer can also be operated in Measurement Window Mode as a standard operating mode. This mode offers the possibility of displaying up to three measuring or calculating values simultaneously. An example with three measurements is shown in Figure 6.

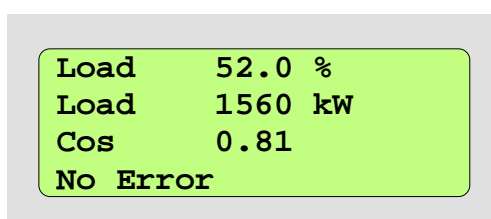



Figure 6: LCD in Measurement Window Mode

For each of the measurements, an abbreviated identifier, the current value and the measuring unit are indicated, and the displayed values are updated continuously.

The fourth line serves for indicating currently occurring errors. If several errors are active, the error indication will cyclically display the individual errors in turn. If currently no error has occurred, this line will read

“No Error”.

Table 4 below lists the operating options in Measurement Window Mode.

Action	Keys
Show next/preceding group of measurements	 



Action	Keys
Activation of the Function Selection Menu	
Stop/Continue updating the indication values	

Table 4: Operating Options in Measurement Window Mode

4.4 Function Selection Menu

The Function Selection Menu is to be activated by actuating the key ‘*Function/Escape*’ when the Hand Programmer is being used in the initial state of either standard operating mode (see also sections ↑ 4.2 *Programmer Mode* and ↑ 4.3 *Measuring Window Mode*). This menu allows to invoke additional functions of the Hand Programmer or to change over to other operating modes.

Figure 7 shows the display with the menu for the selection of functions where the selected function is displayed with its text line blinking and where it may be activated by pressing the key ‘*Enter*’.

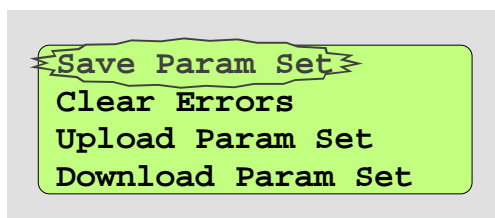

Figure 7: LCD with Function Selection Menu

Table 5 below lists the operating options of the Function Selection Menu.





Action	Keys
Select next/preceding menu item	 
Execute function selected	
Exit menu, return to the standard operating mode selected last	

Table 5: Operating Options of the Function Selection Menu

The possible menu items are explained in the below Table 6 listing the display entries and brief descriptions of their functions. Depending on the type of control unit and its specific functionality, the Function Selection Menu will show but a restricted number of functions.

Function Selection Menu	Brief Description
<i>'Parameter Display'</i>	Change-over to Programmer Mode
<i>'Measurement Window'</i>	Change-over to Measurement Window Mode
<i>'Read Error Memory'</i>	Read out error memory error environment data
<i>'Save Param Set'</i>	Store data in control unit
<i>'Clear Errors'</i>	Clear current errors
<i>'Clear Error Memory'</i>	Clear error memory
<i>'Clear Operating Data'</i>	Clear operating data
<i>'Upload Param Set'</i>	Upload parameter data set from control unit into memory of Hand Programmer
<i>'Download Param Set'</i>	Download parameter data set from memory of Hand Programmer to control unit
<i>'Mask On/Off'</i>	Enable/Disable parameter mask
<i>'Param In Mask On/Off'</i>	Modify parameter mask in control unit
<i>'Panel Settings/Info'</i>	Settings of Hand Programmer
<i>'Automatic Adjust'</i>	Automatic adjustment of actuator
<i>'Start Click-Test'</i>	Activate click test
<i>'Stop Click-Test'</i>	De-activate click test
<i>'Reset Control Unit'</i>	Reset control unit

Table 6: Overview of Function Selection Menu

In the following sections, every menu function is described in more detail. On exiting the individual functions the Hand Programmer will change back to the operating mode in which the Function Selection Menu had been selected.

4.4.1 Changing Over to Programmer Mode

The function *'Parameter Display'* switches the Hand Programmer over into Programmer Mode as a standard operating mode.

This menu item is displayed only if the control unit supports the Measurement Window Mode and if the Function Selection Menu has been called from out of the Measurement Window Mode. If in Function Selection Menu the menu item *'Parameter Display'* is

not displayed, then the change-over to Programmer Mode is as before achieved by pressing the key '*Function/Escape*'.

4.4.2 Changing Over to Measurement Window Mode

By calling the function '*Measurement Window*' the Hand Programmer is switched over into Measurement Window Mode as a standard operating mode.

This menu item is displayed only if the control unit supports the Measurement Window Mode and if the Function Selection Menu has been called from out of the Measurement Window Mode. If in Function Selection Menu the menu item '*Measurement Window*' is not displayed, then the change-over to Measurement Window Mode is as before achieved by pressing the key '*Function/Escape*'.

4.4.3 Read Out Error Memory and Error Environment Data

The menu item '*Read Error Memory*' is available for the user only if the control unit supports the expanded error memory with error environment data. On activating the function '*Read Error Memory*' the first allocated storage location, i.e. the first error stored, will be output by the display.

The below Figure 8 shows an example of Error Memory Indication

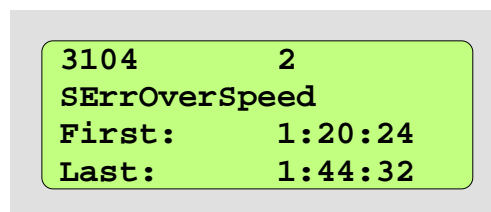

Figure 8: LCD Error Memory Indication

For the first two lines the layout of Error Memory Indication is the same as for the familiar standard presentation of a parameter/measurement consisting of number, value and name. The actual parameter value indicates the number of occurrences of the respective error since clearing the error memory the last time (see also section [↑ 4.4.6 Clear Error Memory](#)). On the third and fourth lines of the display, the time of the first and the last occurrence of the error is indicated by Error Memory Indication. This point in time is identical with the current state of the working hour meter which is recording the engine operating time.

Errors occurring but once and disappearing immediately (such as a loose contact) will be recorded only once per second. Since the time difference by seconds relates to the working hour meter this implies that these errors will continue to be recorded only with the engine running.

In addition, the so-called error environment data are also stored together with the time of the error's occurrence. The maximum number of recordable environment data is preset by the control unit. For all possible error conditions of the control unit, the same environment data will be stored but, of course, each time with the actual value of the last occurrence of the error.

The error environment data can be viewed from out of the Error Memory Indication. An example of the layout of the display showing error environment data is

Figure 9 shows an example of the layout of the display indicating error environment data.

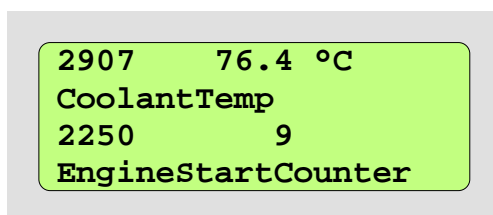

Figure 9: LCD Indication of Error Environment Data

The Hand Programmer presents within one display window of the Indication of Error Environment Data two environment variables by their parameter numbers, stored values, units and names.

Table 7 lists the operating options for reading out error environment data from the control unit.





Action	Keys
Indication of error memory: Select next/preceding Error Memory Indication	 
Proceed to next indication of error environment data until there is another error memory indication	
Error Memory Indication: Exit menu, return to standard operating mode selected last	
Indication of Error Environment Data: Return to Error Memory Indication	

Table 7: Operating Options for Reading Out Error Environment Data

If the error memory does not contain any stored data the display will for about two seconds show the message

“Error memory is empty”

before returning to the standard operating mode used last.

4.4.4 Store Data in Control Unit

The control unit will store any modified parameter values in the volatile memory only. It is only by selecting the menu item ‘*Save Param Set*’ that the control unit will store the data in its permanent memory so that after a reset the last adjustments of the parameter will be the valid ones.

The user is informed about the storage procedure by the display reading

“Saving param values in governor”.

Subsequently, the display will for about two seconds signal whether storage has been successful either by a positive message

“Saving of param values was successful”

or in the negative:

“Param values couldn't be saved”.



Note

In normal cases, the control unit will immediately operate using the new values. Some parameter changes, however, require storing the data in the permanent memory and resetting the control unit before the new values are accepted. All of these parameters are safety relevant and are described in the documentations of the control units.

4.4.5 Clear Current Errors

By invoking the menu function ‘*Clear Errors*’ all currently active errors and error messages on the control unit will be cleared. While the clearing procedure within the control unit is being executed the message

“Clearing errors”

is output by the display. Errors whose causes were not eliminated will be active again immediately after clearance and continue to be output on the fourth line of the display.

4.4.6 Clear Error Memory

By activating the menu item ‘*Clear Error Memory*’ the complete internal error memory of the device including the associated error environment data (see section [↑ 4.4.3 Read Out Error Memory and Error Environment Data](#)), as well as the currently active errors will be reset or cleared, respectively. Errors whose causes were not eliminated will be active again immediately after clearance and continue to be output on the fourth line of the display.

This is visualized by the display showing the messages

“Clearing error memory”

while clearance is executed, and then for about two seconds

“Clearing of error memory was successful”

when clearance has been successful, or

“Error memory couldn't be cleared”

as an error message.

Depending on the access level, this feature is password protected. The error memory cannot be cleared unless a password has been entered by the user.

Figure 10 exhibits the layout of the display for entering a password.

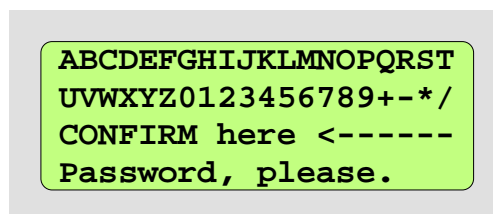

Figure 10: LCD Password Input

Navigation through the screen for password input is by means of the cursor keys. The first two lines serve for selecting the characters of the password whereas by confirming the entered password on the third line clearance of the error memory will be initiated. Erroneous input is signalled by the error message

“Invalid password”.

Table 8 gives an overview of the possible inputs.







Action	Keys
Moving among the characters of the lines 1 and 2	 
Changing over between the lines 1, 2 and 3	 
Exit menu, return to standard operating mode selected last	
Selection of characters from lines 1 and 2, or acknowledgment of password in line 3	

Table 8: Password Input



Note

The password can be requested or purchased from HEINZMANN. Specification of the password will require the serial number and the identification number of the diagnosis tool to be communicated as exhibited on its type plate.

4.4.7 Clear Operating Data

The menu item ‘*Clear Operating Data*’ is available only for control units equipped with an operating data storage. Activating this function will clear or reset the operating data within the control unit. Which data has been stored as operating data and will be erased by this action is explained in the documentation of the control unit.

While clearance is being executed, the display will read:

“Clearing operational data”.

The message

“Clearing of operational data was successful”

will signal the user for about two seconds that resetting the operating data has been successful, and

“Operational data couldn't be cleared”

that resetting has failed.

Depending on the access level, execution of this function will require entering a password. Password input is described in section [↑ 4.4.6 Clear Error Memory](#).

4.4.8 Upload Parameter Data Set

The routine ‘*Upload Param Set*’ permits to transfer all current parameter values from the connected control unit to the Hand Programmer where the uploaded data set will be stored in the internal permanent memory. It will be not be possible to store more than one single parameter data set in the Hand Programmer which implies that any previously stored data set is going to be overwritten.

On invoking the upload of a data set, it is executed automatically without any further confirmation. Execution is indicated by the message:

“Receiving data from the control unit”

and by a progress bar on the fourth LCD line. The time required for transferring the data will depend on the number of parameters.

On terminating execution of this function, success will be signalled for about two seconds by the positive message

“Reception complete!”

Otherwise one of the following error messages will be output:

“Abort, because not enough memory!”

“Abort, because communication or E²PROM access error!”

4.4.9 Download Parameter Data Set

The routine ‘*Download Param Set*’ can be used to transfer a parameter data set stored in the internal permanent memory of the Hand Programmer to the connected control unit (see also section \uparrow 4.4.8 *Upload Parameter Data Set*). Prior to transferring the data, both the software version numbers of the control unit and of the data set stored in the permanent memory will be displayed to be checked for consistency. After checking on the correctness of the software version numbers, the procedure is to be confirmed by actuating the ‘*Enter*’ key. In case of doubts, the routine must at this point be aborted by the key ‘*Function/Escape*’. Further visualization for the user is by the message

“Transmitting data to the control unit”

and by a progress bar on the fourth LCD line. The data will have been successfully transferred to the control unit when the display reads the message

“Save param values in governor?”

Otherwise, the respective negative message

“Abort, because of communication or E²PROM access error!”

will be displayed. When transferring the parameter values has been successful, the data can immediately be stored in the control unit without any further acknowledgment by means of the ‘*Enter*’ key, see also section \uparrow 4.4.4 *Store Data in Control Unit*. On pressing the key ‘*Function/Escape*’ the parameter values are not stored, but will be temporarily available in the volatile memory area.

This routine will be automatically aborted with the below error message in case:

- no data set has been stored in the internal permanent memory: *“No dataset stored in the memory”*,
- some inconsistent data set has been stored in the internal permanent memory: *“Abort, because the dataset is inconsistent!”*, or
- the versions numbers of the hardware of the control unit and that of the data set stored in the internal memory are not identical: *“Abort, because the hardware version is different!”*.

These error messages will be output by the display for about two seconds.

**Note**

It is always the complete data set that is going to be downloaded. Due to this, it cannot be excluded that also such parameter values are overwritten that must necessarily be different for different control units or even for different software versions. For more detailed information, please refer to the documentations of the specific control units being used.

4.4.10 Using Parameter Masks/User Masks

To enhance perspicuity when the Hand Programmer is operating in Programmer Mode, the number of accessible parameters may be reduced by activating a parameter mask/user mask. However, as this functionality depends on the system being used the specific functions will not be available in the Function Selection Menu for certain control units.

A parameter can be included in the mask or removed from it by calling the Function Selection Menu with the respective parameter displayed in Programmer Mode and then selecting the menu item '*Param In Mask On/Off*'.

The mask itself is to be enabled or disabled by selecting the item '*Mask On/Off*' from the Function Selection Menu. When trying to enable the mask when no parameter has been parameterized for the mask, the display message

"No parameter in mask!"

will be output.

In Programmer Mode, the status of the mask with respect to the parameter currently displayed will be indicated at the end of the third line:

- On* The parameter mask/user mask is not active; the parameter is being displayed even if the mask is active,
- Off* The parameter mask/user mask is not active; the parameter is not displayed when the mask is active,
- MASK* The parameter mask/user mask is active; only the parameters included in the mask will be displayed.

**Note**

Similarly to the modification of parameter values, parameterization of the parameter mask/user mask is performed only in the volatile memory of the control unit. If the parameterization made is to be preserved permanently the data must be stored in the control unit, see section ↑ 4.4.4 Store Data in Control Unit.

4.4.11 Hand Programmer Settings and Device Information

The menu item ‘Panel Settings/Info’ permits adjustment of brightness and contrast of the LC display and serves to indicate status values and electric operating parameters of the Hand Programmer. There are four different display windows that can be chosen.

The first window serves for indicating and setting the values for brightness and contrast of the display and, in addition, for indicating the version number of the firmware of the diagnosis tool.







The second window serves to indicate the actual voltage value of the supply voltage provided by the control unit as well as the internal 5 Volts reference voltage.

The third and fourth windows show the system data of the Hand Programmer:

- the permanently programmed maximum user level,
- the identification number,
- serial date and serial number, and
- the valid access masks.

These data are also displayed during the initialization phase.

Table 9 shows the input options during indication of the settings and the device information for the Hand Programmer:

Action	Keys
Adjustment of contrast and brightness (first window only)	
Adjustment of contrast and brightness: Changing places (lines 1 and 2 only)	 
Adjustment of contrast and brightness: Incrementing/Decrementing the value of the blinking place	 
Adjustment of contrast and brightness: Terminating input without confirming the modifications	





Action	Keys
Adjustment of contrast and brightness: Changing from brightness to contrast	
Adjustment of contrast: Confirming entries	
Switching between the windows	 
Exit menu, return to standard operating mode selected last	

Table 9: Settings and Device Information

4.4.12 Automatic Actuator Adjustment

The item ‘*Automatic Adjust*’ of the Function Selection Menu can be enabled only with control units on engines with conventional injection. When invoked, an automatic adjustment of the control unit connected is executed. If the control unit has been configured for several actuators, one actuator must have been selected in advance. The procedure is described in Table 10.





Action	Keys
Select next/previous actuator	 
Confirm selected actuator	
Exit menu, return to standard operating mode selected last	

Table 10: Selection of Actuator

Due to an additional safety prompt, there exists the possibility of either abandoning the procedure via the key ‘*Function/Escape*’ before executing the automatic adjustment and to return to the standard operating mode selected last, or of enabling execution definitely by pressing the key ‘*Enter*’.

The display of the Hand Programmer will then show the message

“Adjusting actuator, wait please...”

until acknowledgment by the control unit is received. The user is signalled successful execution for about two seconds by the message

“Actuator adjust finished successfully”.

In case automatic adjustment could not be executed properly one of the following error messages will be displayed instead of indication of success:

- *“Selected actuator isn't connected.”* if the selected actuator had not been connected.
- *“Actuator adjust couldn't be started”* if automatic adjustment could not be started, or
- *“Error on actuator adjust”* if some error has occurred during automatic adjustment.

These are potential error causes of the last two error messages:

- The speed pickup is sensing engine speed above zero, i.e., the engine is running.
- The speed pickup is sensing engine speed greater than zero although the engine is not running. In this case, it might be the cabling of the actuator and/or the speed pickup that is causing the error. If the cable screening is missing or wrongly connected the actuator current may cross feed upon the speed pickup line and simulate speeds greater than zero.
- The line of the control unit is interrupted so control current cannot flow.
- With any feedback error active, automatic actuator adjustment will not be possible. In this case the error limits for the actuator feedback must temporarily be set to zero and maximum until adjustment has been performed..



Note

For detailed descriptions of the procedure of automatic actuator adjustment and its effects on the existing system, and for the necessary manual adjustments, please refer to the documentations of the control units that are being used.

4.4.13 Activate/De-activate Click Test

The click test function is available only with control units on engines with electronically controlled injection systems.

This menu item permits to check the order of actuation of the magnetic valves and consequently that of their cabling. It should by all means be invoked before the engine is started for the first time. This test cannot be enabled unless the engine is standing, and with common rail engines there is an additional check to ensure that injection pressure is below 20 bar to prevent fuel from being injected.

During this testing procedure all magnetic valves are shortly actuated cyclically one after another in the order of A1, A2, ... , B1, B2, ... with a delay of 1.5 seconds. On

switching banks from A to B or from B to A the delay time will be 10 seconds. Checking on the correct firing order is conducted acoustically on the engine by the operator.

The click test cycle is started by confirming the menu item '*Start Click Test*' and will continue until the user stops the test by '*Stop Click Test*'. With each execution, the menu item changes its labelling indicating which action will be performed next.

The respective messages:

- "*Click-Test is activated.*" for activated click test,
- "*Click-Test is deactivated.*" for de-activated click test,
- "*Click-Test couldn't be started.*" if the click test could not be started, and
- "*Click-Test couldn't be stopped.*" if the click test could not be terminated,

will after acknowledgment be output on the display for about two seconds to inform the user about the status of the click test.

4.4.14 Reset Control Unit

The menu item '*Reset Control Unit*' is available only with control units supporting the automatic reset function. After selecting this menu function, execution of the reset may either be confirmed by pressing '*Enter*' or denied by pressing '*Function/Escape*' which will lead back to the standard operating mode selected last without executing a reset.

While the reset is being executed the Hand Programmer will display the following message:

"Waiting for Reset...".

Following the successful execution of the reset, communication with the control unit will build up again.

If due to reasons of safety the reset cannot be executed – a reset will, e.g., be possible only with the engine standing – a message to this effect will be output for about two seconds

"Reset not possible Engine is running".

4.5 Hand Programmer in PC Operating Mode

As an additional operating option, the Hand Programmer offers the so-called PC Operating Mode where it is used in combination with the Windows programme DcDesk 2000. For more detailed information on the functionality of DcDesk 2000, please refer to the operating instructions of the communication programme DcDesk 2000 by HEINZMANN.

For utilizing the PC Operating Mode, the following steps have to be taken:

- Connect the Hand Programmer to a PC via the additional Adapter PC–Hand Programmer HP 03 (see also section ↑ 5.3.4 Adapter PC – Hand Programmer HP 03),
- Use mains supply unit to establish voltage supply,
- Keep key ‘Function/Escape’ pressed during the initialization phase until the message “Waiting for command from DcDesk 2000” is being output by the display,
- Run DcDesk 2000 on the PC and call the item “Hand Held Programmer” from the menu “Extras”.

As soon as DcDesk 2000 has successfully recognized the Hand Programmer, the window ‘Hand Programmer’ as shown in Figure 11 will be active.

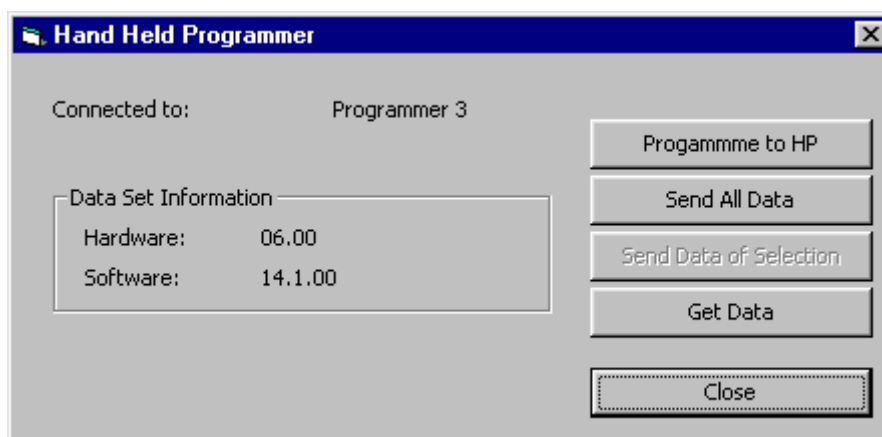

Figure 11: DcDesk 2000 Window Hand Programmer

The Hand Programmer window of the PC software DcDesk 2000 contains the relevant information on the type of the Hand Programmer connected and the version numbers of the hardware and software of the control unit data set stored in the internal permanent memory of the Hand Programmer. The following sections contain descriptions of the signification of the buttons and their functionalities.

4.5.1 Programme to HP

This button will be available only if the dongle of DcDesk 2000 permits access by at least level 6. By this feature, it is possible to update the firmware of the Hand Programmer itself.

4.5.2 Send All Data

When with DcDesk 2000 in offline mode a control unit and the respective parameter file have been loaded, this button will be enabled. It may then be employed to send to

the Hand Programmer and store there as a data set all parameter values that are contained in the four lists and buffer them there. The Hand Programmer can then forward this data to the respective control units.

Data transfer is signalled on the Hand Programmer's display by the message:

“Receiving data form DcDesk 2000”.

4.5.3 Send Data of Selection

When with DcDesk 2000 in offline mode, a control unit and an associated parameter file have been loaded and a selection activated, this button will be enabled. It can then be used to send the parameter values of the selection to the Hand Programmer where they will be stored as a data set that may in its turn be sent to other control units of the same type.

Data transfer is signalled on the Hand Programmer's display by the message:

“Receiving data form DcDesk 2000”.

4.5.4 Get Data

On clicking this button, the parameters stored in the Hand Programmer will be loaded into the list windows of DcDesk 2000 provided DcDesk 2000 has been connected at least once with the type control unit the data set in the Hand Programmer is coming from. A selection is automatically made from the parameters received.

DcDesk 2000 will then be able to store the values in parameter files via the usual menu items.

During transfer of data the display of the Hand Programmer will show the text:

“Transmitting data to DcDesk 2000”.

4.5.5 Close

By clicking the button “Close” the Hand Programmer window is exited and the programme returns directly to the DcDesk 2000 Main Window.

5 Technical Data

5.1 Specification

Operating voltage	9 V to 32 V DC (directly from control unit)
Current consumption	<100 mA
LC display	4 x 20 characters, backlit
Keypad	Foil keyboard, 7 keys
Connector	Communication: 1 x 8-pole, male
Admissible ambient temperatures	
Storage	-40 °C to +70 °C
Operation	0 °C to +50 °C
Admissible air humidity	max. 70 %
Protection grade	IP 23
Weight	0.3 kg

5.2 Device Dimensions

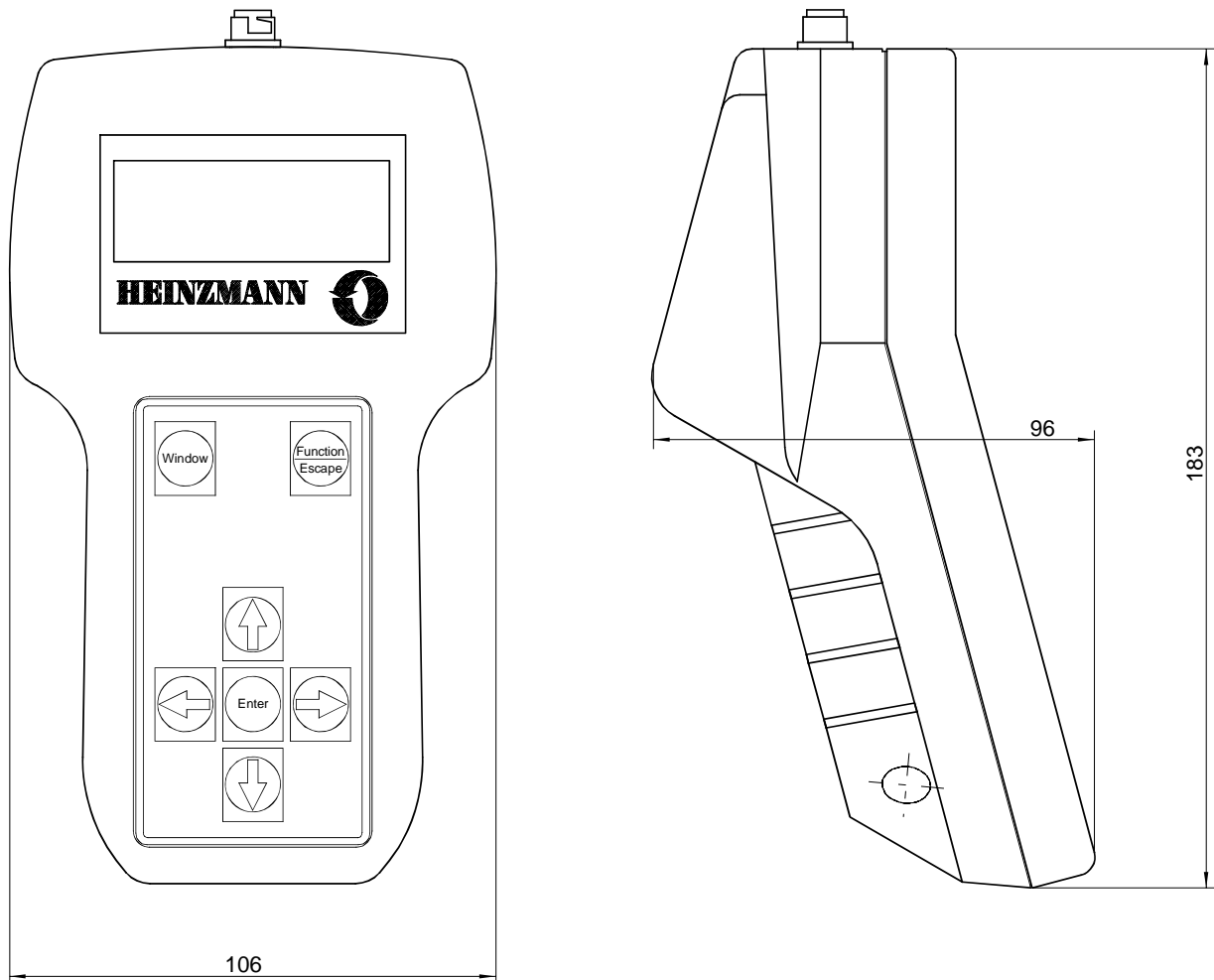

Figure 12: Dimensions Hand Programmer

Order Number : 620-00-054-04

5.3 Connection Cables

The figures contained in this chapter are not true to scale and should, therefore, be interpreted as schematic drawings.

5.3.1 Adapter Governor – Hand Programmer HP 03

The adapter Governor – Hand Programmer HP 03 is to be used for control types with Sub-D 9-pole communication sockets, such as: HELENOS, THESEUS, PANDAROS, KRONOS, HELIOS2 and PHAETON.

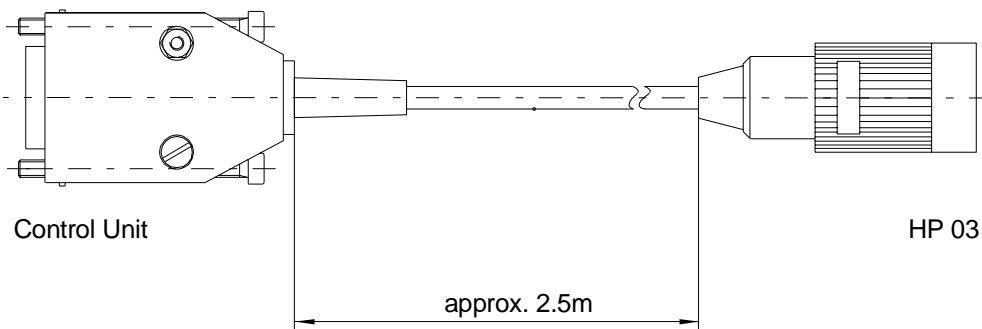

Figure 13: Dimensions Adapter Governor – HP 03

Order Number: 620-00-059-00

5.3.2 Adapter Hand Programmer HP 03 – DC 1-03

The adapter Hand Programmer HP 03 – DC 1-03 is to be used for control types with CANNON communication sockets, such as PRIAMOS and ARTEMIS.

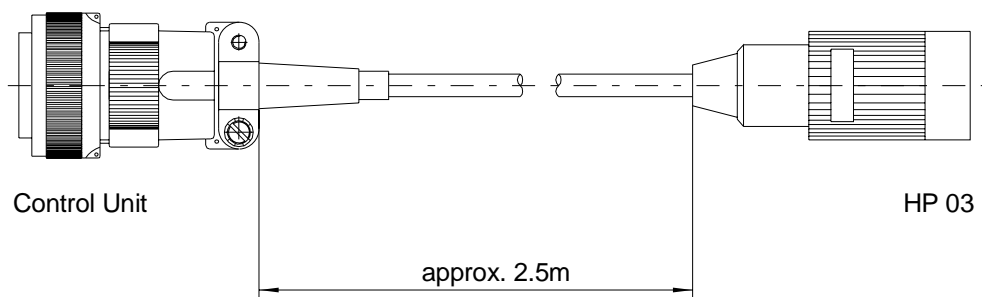

Figure 14: Dimensions Adapter HP 03 – DC 1-03

Order number: 620-00-067-00

5.3.3 Adapter Hand Programmer HP 03 – MVC

The adapter Hand Programmer HP 03 – MVC is to be used exclusively with control units type MVC01 or DARDANOS.

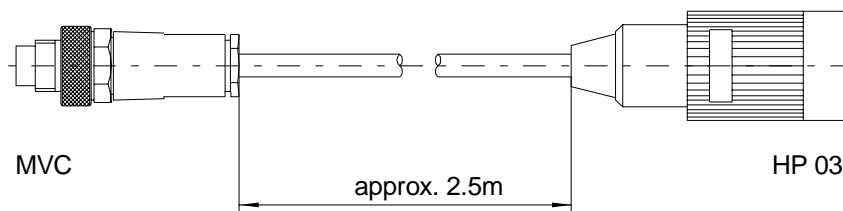

Figure 15: Dimensions Adapter HP 03 – MVC

Order number: 620-00-068-00

5.3.4 Adapter PC – Hand Programmer HP 03

The adapter PC – Hand Programmer HP 03 is to be used for connection with the PC for communication with DcDesk 2000.

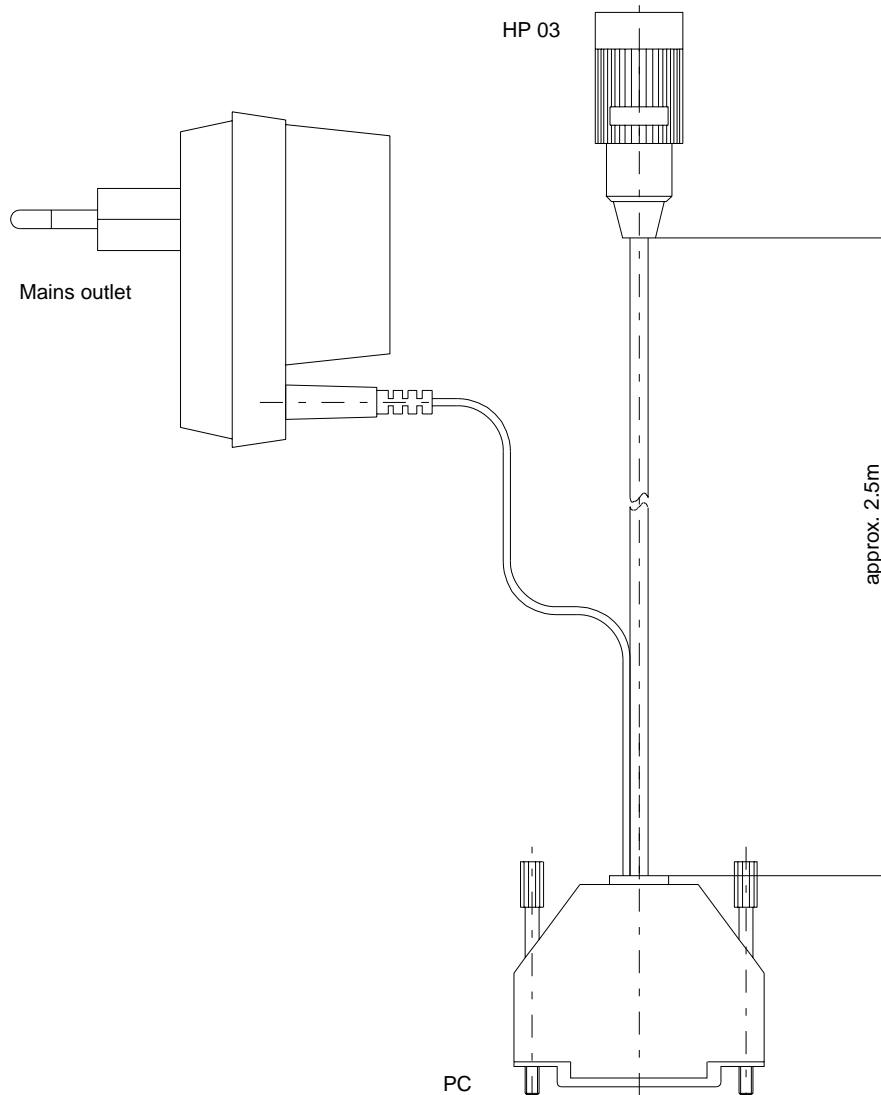

Figure 16: Dimensions Adapter PC – HP 03

Order number: 620-00-058-00

6 Index of Figures

Figure 1: LCD in Programmer Mode	6
Figure 2: LCD in Measurement Window Mode	6
Figure 3: LCD in Function Selection Mode	6
Figure 4: Keypad	7
Figure 5: LCD in Programmer Mode	9
Figure 6: LCD in Measurement Window Mode	10
Figure 7: LCD with Function Selection Menu	11
Figure 8: LCD Error Memory Indication	13
Figure 9: LCD Indication of Error Environment Data	14
Figure 10: LCD Password Input	16
Figure 11: DcDesk 2000 Window Hand Programmer	24
Figure 12: Dimensions Hand Programmer	27
Figure 13: Dimensions Adapter Governor – HP 03	28
Figure 14: Dimensions Adapter HP 03 – DC 1-03	28
Figure 15: Dimensions Adapter HP 03 – MVC	28
Figure 16: Dimensions Adapter PC – HP 03	29

7 Index of Tables

Table 1: Access Level	5
Table 2: Basic Key Functions	7
Table 3: Operating Options in Programmer Mode.....	10
Table 4: Operating Options in Measurement Window Mode	11
Table 5: Operating Options of the Function Selection Menu	11
Table 6: Overview of Function Selection Menu	12
Table 7: Operating Options for Reading Out Error Environment Data	14
Table 8: Password Input.....	16
Table 9: Settings and Device Information.....	21
Table 10: Selection of Actuator	21

8 Index

Access Authority	20	Adapter HP 03 – MVC	29
Access Authorization	4, 8	Adapter PC – HP 03	29
Access Level	<i>see</i> Level	HP 03–03	27
Access Mask	<i>see</i> Access Authorization	Parameter Mask	9, 19
Automatic Adjustment	21	Parameters	4, 8, 19
Click Test	22	Abbreviated Identifier	10
Control Panel	7	Characteristics and Maps	4
DcDesk 2000	23	Data Set	17, 18
Display		Function Parameters	4
Brightness	20	Groups	4
Contrast	20	Measurements	4, 8, 10
Display Element	6	Measuring Unit	4, 9, 10
Error Environment Data	13, 15	Name	4, 9, 13
Error Indication	9, 10	Number	4, 9, 13
Error Memory	13, 15	Value	4, 9, 10, 13, 15, 17, 25
Error Memory Indication	13	Value Range	4, 9
Firmware	20, 24	Password Input	16, 17
Identification Number	4, 8, 20	Reference Voltage	20
Indication of Error Environment Data	14	Reset	5, 8, 15, 23
Level	4, 8, 16, 17, 20, 24	Serial Date	20
Memory		Serial Number	8, 20
Permanent Memory	5, 15	Software Version	4
Volatile Memory	5	Supply Voltage	20
Volatile Memory	18	User Level	<i>see</i> Level
Order Number		User Mask	<i>see</i> Parameter Mask
Adapter Governor – HP 03	28	Working Hour Meter	13
Adapter HP 03 – DC 1-03	28		

9 Order Specifications for Manuals

There is no charge for technical manuals ordered in reasonable quantities.

Order the necessary manuals on our speed governors from your nearest

[HEINZMANN location](#).

(Please click on “HEINZMANN location” to see the list of our subsidiaries and agents in the world).

Please include the following information:

- your name,
- the name and address of your company (you can simply include your business card),
- the address where you want the manuals sent (if different from above),
- the number(s) and title(s) of the desired manual(s) or
- technical data of your **HEINZMANN** equipment and
- the quantity you want.

You can directly use the following fax-form for ordering one or several manuals.

Most of the manuals are available as acrobat PDF-files, too. On request they can be send via e-mail.

We solicit comments about the content and the presentation of our publications. Please, send your comments to:

HEINZMANN GmbH & Co. KG

Service Department

Am Haselbach 1

D-79677 Schönau

Germany

Fax Reply

Order for HEINZMANN technical manuals

Fax Hotline +49 7673 8208 194

Please send me the following brochures:

Quantity	Manual Reference Number	Title

Please send me your new sales documentation on

- () HEINZMANN Analogue Controls. Application:
- () HEINZMANN Digital Controls. Application:
- () HEINZMANN Gas Engine Equipment. Application:

Company

Contact

Department

Address..... Country/Code/Town.....

Phone..... Fax

e-mail.....

Activity.....

Date