



Heinzmann GmbH & Co. KG

Engine & Turbine Controls

Am Haselbach 1
D-79677 Schönau (Schwarzwald)
Germany

Phone +49 7673 8208-0

Fax +49 7673 8208-188

E-mail info@heinzmann.com





www.heinzmann.com

V.A.T. No.: DE145551926

HEINZMANN®
Electronic Speed Governor

Electronic Setpoint Potentiometer

ESW 01

 <p>Warning</p>	<p>Read this entire manual and all other publications appertaining to the work to be performed before installing, operating or servicing your equipment.</p> <p>Practice all plant and safety instructions and precautions.</p>
 <p>Danger</p>	<p>Failure to follow instructions may result in personal injury and/or damage to property.</p> <p>HEINZMANN will refuse all liability for injury or damage which results from not following instructions</p>
 <p>Danger! High Voltage</p>  <p>Danger</p>	<p>Please note before commissioning the installation:</p> <p>Before starting to install any equipment, the installation must have been switched dead!</p> <p>Be sure to use cable shieldings and power supply connections meeting the requirements of the <i>European Directive concerning EMI</i>.</p> <p>Check the functionality of the existing protection and monitoring systems.</p>
 <p>Danger</p>	<p>To prevent damages to the equipment and personal injuries, it is imperative that the following monitoring and protection systems have been installed:</p> <p>Overspeed protection acting independently of the speed governor</p> <p>Overtemperature protection</p> <p>HEINZMANN will refuse all liability for damage which results from missing or insufficiently working overspeed protection</p> <p>Generator installation will in addition require:</p> <p>Overcurrent protection</p> <p>Protection against faulty synchronization due to excessive frequency, voltage or phase differences</p> <p>Reverse power protection</p>
	<p>Overspeeding can be caused by:</p> <p>Failure of the voltage supply</p> <p>Failure of the actuator, the control unit or of any accessory device</p> <p>Sluggish and blocking linkage</p>



Warning

The examples, data and any other information in this manual are intended exclusively as instruction aids and should not be used in any particular application without independent testing and verification by the person making the application.



Danger

Independent testing and verification are especially important in any application in which malfunction might result in personal injury or damage to property.

HEINZMANN make no warranties, express or implied, that the examples, data, or other information in this volume are free of error, that they are consistent with industry standards, or that they will meet the requirements for any particular application.

HEINZMANN expressly disclaim the implied warranties of merchantability and of fitness for any particular purpose, even if **HEINZMANN** have been advised of a particular purpose and even if a particular purpose is indicated in the manual.

HEINZMANN also disclaim all liability for direct, indirect, incidental or consequential damages that result from any use of the examples, data, or other information contained in this manual.

HEINZMANN make no warranties for the conception and engineering of the technical installation as a whole. This is the responsibility of the user and of his planning staff and specialists. It is also their responsibility to verify whether the performance features of our devices will meet the intended purposes. The user is also responsible for correct commissioning of the total installation.

Contents

	Page
1 Safety Instructions and Related Symbols.....	1
1.1 Basic Safety Measures for Normal Operation.....	2
1.2 Basic Safety Measures for Servicing and Maintenance	2
1.3 Before Putting an Installation into Service after Maintenance and Repair Works.....	3
2 Application.....	4
3 Function Mode.....	5
4 Functional Block Diagram.....	6
5 Specification.....	7
6 Electrical Connection.....	8
6.1 Basic Systems E 1-F and E 2-F	8
6.1.1 Wiring without Manual Potentiometer	8
6.1.2 Wiring with Manual Potentiometer	9
6.2 Basic Systems E 6 to E 40.....	10
6.2.1 Wiring without Manual Potentiometer	10
6.2.2 Wiring with Manual Potentiometer	10
6.3 Basic System E 2000	11
6.3.1 Wiring without Manual Potentiometer	11
6.3.2 Wiring with Manual Potentiometer	11
7 Measurements.....	12
7.1 Plastic Case for DIN Skid Mounting.....	12
7.2 Metal Case	13
8 Adjustment.....	14
8.1 Operation and Indication Elements	14
8.2 Adjustment of Installations without Manual Potentiometer.....	15
8.3 Adjustment of Installations with Manual Potentiometer.....	16
9 Order Specifications.....	17
10 Figure List.....	18
11 Order Specifications for Manuals.....	19

1 Safety Instructions and Related Symbols

This publication offers wherever necessary practical safety instructions to indicate inevitable residual risks when operating the engine. These residual risks imply dangers to

persons

product and engine

environment.

The symbols used in this publication are in the first place intended to direct your attention to the safety instructions!



Warning

This symbol is to indicate that there may exist dangers to the engine, to the material and to the environment.



Danger

This symbol is to indicate that there may exist dangers to persons. (Danger to life, personal injury))



**Danger!
High
Voltage**

This symbol is to indicate that there exist particular danger due to electrical high tension. (Mortal danger).



Note

This symbol does not refer to any safety instructions but offers important notes for better understanding the functions that are being discussed. They should by all means be observed and practiced. The respective text is printed in italics.

The primary issue of these safety instructions is to prevent personal injuries!

Whenever some safety instruction is preceded by a warning triangle labelled “Danger” this is to indicate that it is not possible to definitely exclude the presence of danger to persons, engine, material and/or environment.

If, however, some safety instruction is preceded by the warning triangle labelled “Caution” this will indicate that danger of life or personal injury is not involved.

The symbols used in the text do not supersede the safety instructions. So please do not skip the respective texts but read them thoroughly!

In this publication the Table of Contents is preceded by diverse instructions that among other things serve to ensure safety of operation. It is absolutely imperative that these hints be read and understood before commissioning or servicing the installation.

1.1 Basic Safety Measures for Normal Operation

- The installation may be operated only by authorized persons who have been duly trained and who are fully acquainted with the operating instructions so that they are capable of working in accordance with them.
- Before turning the installation on please verify and make sure that
 - only authorized persons are present within the working range of the engine;
 - nobody will be in danger of suffering injuries by starting the engine.
- Before starting the engine always check the installation for visible damages and make sure it is not put into operation unless it is in perfect condition. On detecting any faults please inform your superior immediately!
- Before starting the engine remove any unnecessary material and/or objects from the working range of the installation/engine.
- Before starting the engine check and make sure that all safety devices are working properly!

1.2 Basic Safety Measures for Servicing and Maintenance

- Before performing any maintenance or repair work make sure the working area of the engine has been closed to unauthorized persons. Put on a sign warning that maintenance or repair work is being done.
- Before performing any maintenance or repair work switch off the master switch of the power supply and secure it by a padlock! The key must be kept by the person performing the maintenance and repair works.
- Before performing any maintenance and repair work make sure that all parts of engine to be touched have cooled down to ambient temperature and are dead!
- Refasten loose connections!
- Replace at once any damaged lines and/or cables!
- Keep the cabinet always closed. Access should be permitted only to authorized persons having a key or tools.

- Never use a water hose to clean cabinets or other casings of electric equipment!

1.3 Before Putting an Installation into Service after Maintenance and Repair Works

- Check on all slackened screw connections to have been tightened again!
- Make sure the control linkage has been reattached and all cables have been reconnected.
- Make sure all safety devices of the installation are in perfect order and are working properly!

2 Application

The Electronic Motor Potentiometer ESW 01-1 will be used in combination with the analogue electronic HEINZMANN speed governors E 1-F, E 2 F, E 6 to E 40 and E 2000 as an interface to existing generator sets operating with power control devices. There, they can serve for synchronization and (in droop mode) for adjustment of power output by PLC or some other control signal.

For applications with an extended range of speed adjustment, such as heat pumps, the version ESW 01-2 is provided.

3 Function Mode

The device affects the speed setpoint by adding a positive or negative signal from an integrator circuit to raise or lower the governor's speed setting.

When the unit is powered up, the integrator will be set to neutral position. This can any time also be achieved by bridging the terminals 10 and 11. As long as these terminals are connected the integrator will be kept in neutral position regardless of the signals of the Up/Down inputs. Once the connection is interrupted again the integrator will be able to process the Up/Down signals. The integrator is controlled by the Up/Down logics which will also indicate whether the integrator has reached its limit. Green LEDs are provided to indicate the UpDown signals and red LEDs to indicate the limits.

Integration time can be set using the RUN TIME potentiometer.

4 Functional Block Diagram

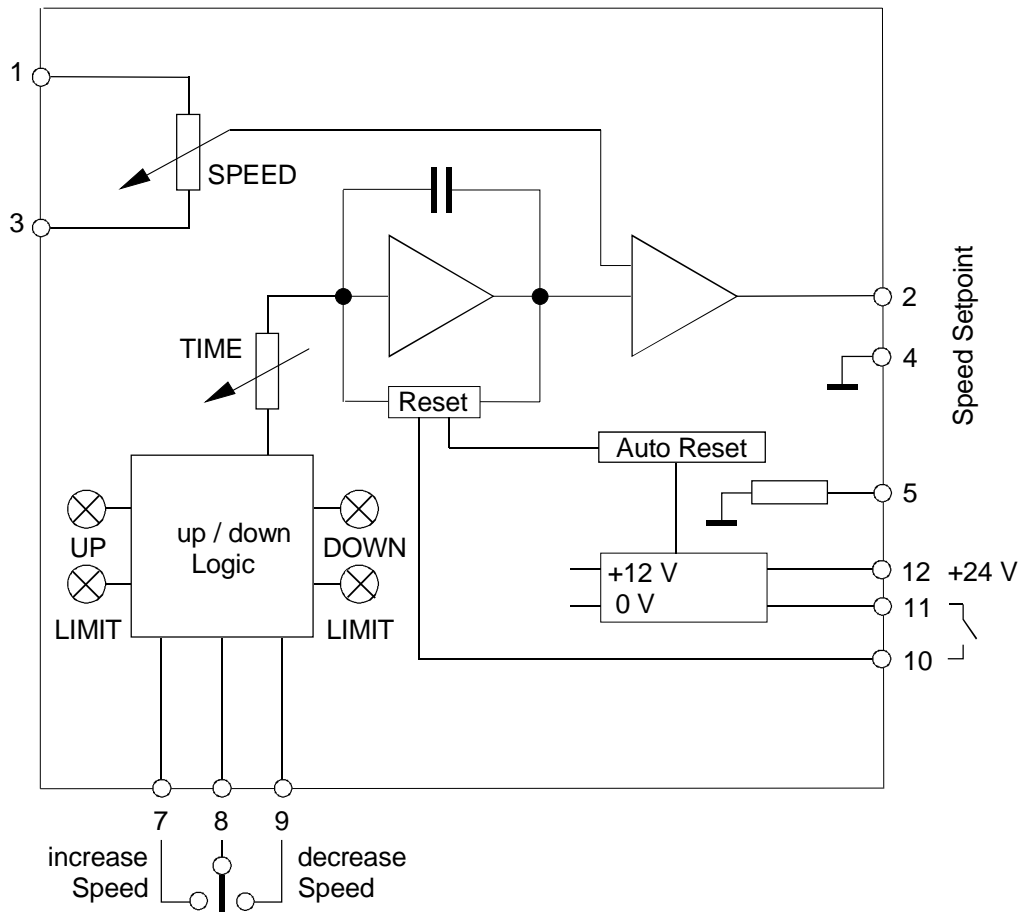

Figure 1: Functional Block Diagram ESW 01

5 Specification

Supply voltage	24 V DC \pm 20%	
Maximum residual ripple of supply voltage	10% at 100 Hz	
Current consumption	approx. 80 mA	
Setpoint voltage range	within 1 – 5 V DC depending on basic system and governor setting	
Variation of setpoint voltage	\pm 250 mV \pm 10 mV	(ESW 01-1)
	1 : 2.5	(ESW 01-2)
Resulting speed variation	\pm 5% of rated speed	(ESW 01-1)
	1 : 2.5	(ESW 01-2)
Minimum settable adjustment time	10 seconds	(ESW 01-1)
	45 seconds	(ESW 01-2)
Maximum settable adjustment time	35 seconds	(ESW 01-1)
	60 seconds	(ESW 01-2)
Speed deviation within 24 hours at +25°C (without adjustment pulses)	max. \pm 0.2 %	(ESW 01-1)
	max. \pm 3 %	(ESW 01-2)
Temperature range	0 to +70 °C	
Protection type		
with plastic case	IP 00	
with metal case	IP 55	
Weight		
with plastic case	0.22 kg	
with metal case	1.7 kg	
EMI suitable version	with metal case	

6 Electrical Connection

The wiring diagrams show the connections to the speed governors systems E 1-F / E 2-F, E 6 to E 40 and E 2000, each including usage of the internal setpoint potentiometer ESW 01 or of the external manual potentiometer. Care should be taken to correctly connect the shielded lines in order to avoid control problems and damages to the governor.

The line connecting the ESW 01 with the E 1-F and E 2-F control units should be chosen as short as possible and by no means exceed the length of 5 meters.

6.1 Basic Systems E 1-F and E 2-F

6.1.1 Wiring without Manual Potentiometer

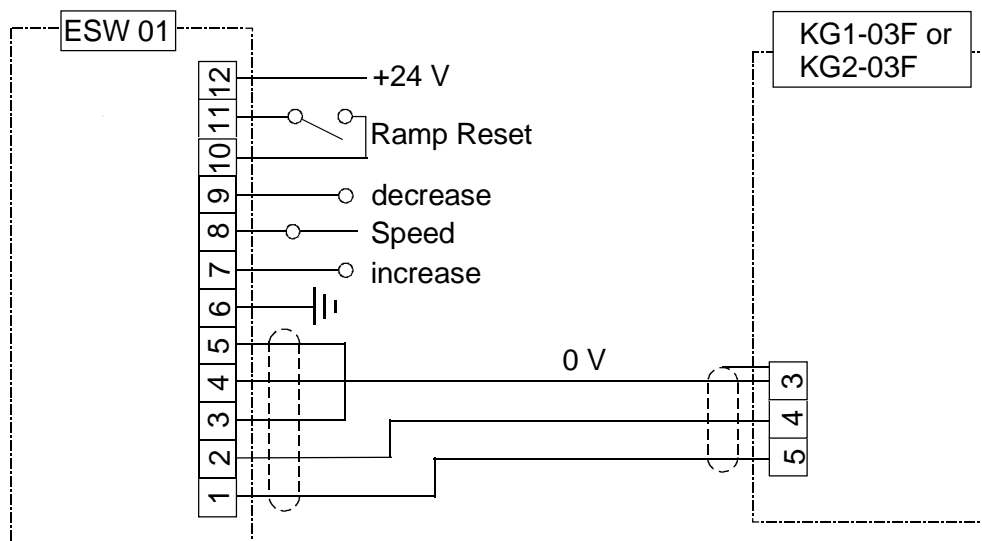

Figure 2: Wiring of ESW 01 for E 1-F and E 2-F

The wiring of 0.V of the supply voltage may be conducted only via the governor, plug 3.

6.1.2 Wiring with Manual Potentiometer

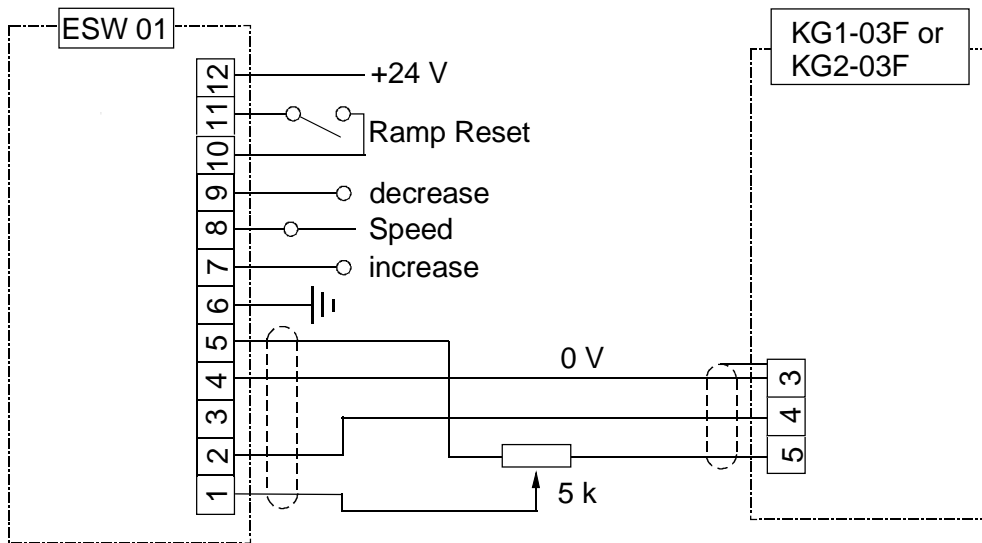

Figure 3: Wiring of ESW 01 for E 1-F and E 2-F with Additional Manual Potentiometer

This mode of connection applies only to ESW 01-02, but not to ESW 01-1 with limited adjustment range.

The wiring of 0.V of the supply voltage may be conducted only via the governor, plug 3.

6.2 Basic Systems E 6 to E 40

6.2.1 Wiring without Manual Potentiometer

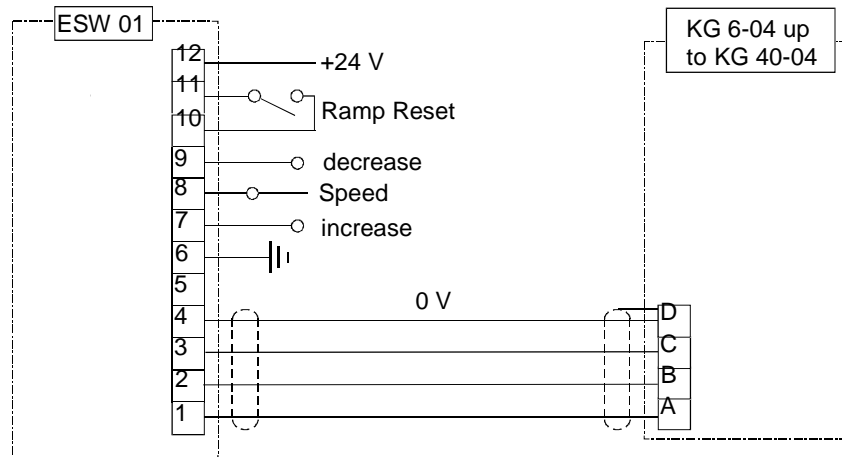

Figure 4: Wiring of ESW 01 for E 6 to E 40

The wiring of 0.V of the supply voltage may be conducted only via the governor, plug 1 pin D or plug 3 pins A or H.

6.2.2 Wiring with Manual Potentiometer

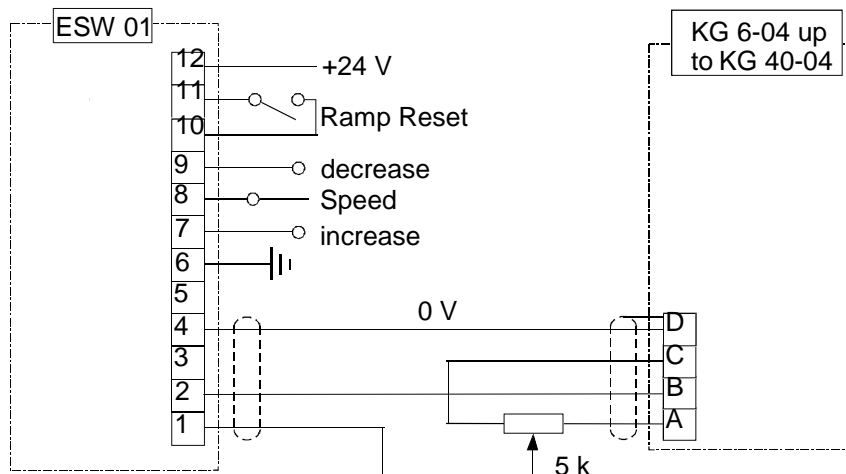

Figure 5: Wiring of ESW 01 for E 6 to E 40 with Additional Manual Potentiometer

This mode of connection applies only to ESW 01-02, but not to ESW 01-1 with limited adjustment range.

The wiring of 0.V of the supply voltage may be conducted only via the governor, plug 1 pin D or plug 3 pins A or H.

6.3 Basic System E 2000

6.3.1 Wiring without Manual Potentiometer

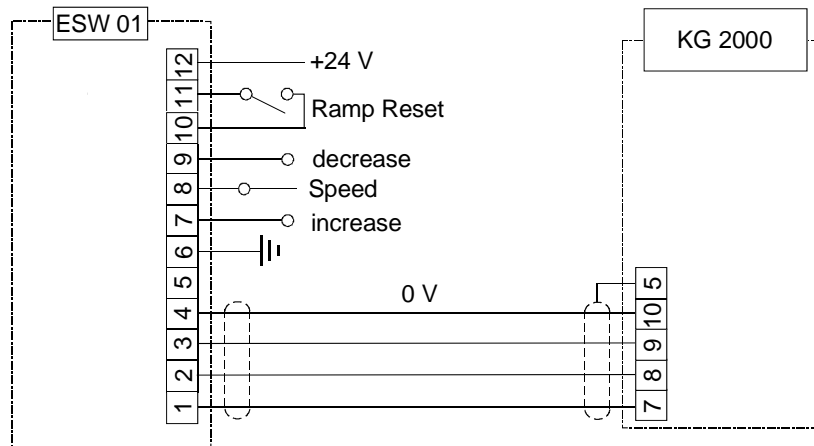

Figure 6: Wiring of ESW 01 for E 2000

The wiring of 0.V of the supply voltage may be conducted only via the governor, plug 1 pin D or plug 3 pins A or H.

6.3.2 Wiring with Manual Potentiometer

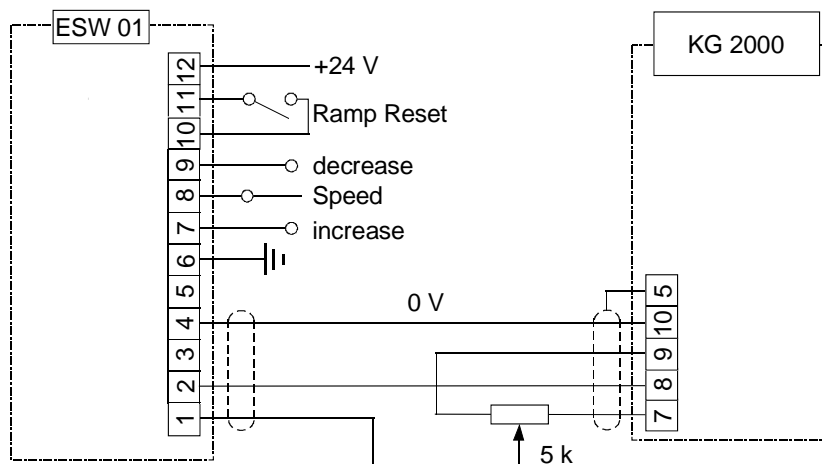

Figure 7: Wiring of ESW 01 for E 2000 with Additional Manual Potentiometer

This mode of connection applies only to ESW 01-02, but not to ESW 01-1 with limited adjustment range.

The wiring of 0.V of the supply voltage may be conducted only via the governor, plug 1 pin D or plug 3 pins A or H.

7 Measurements

7.1 Plastic Case for DIN Skid Mounting

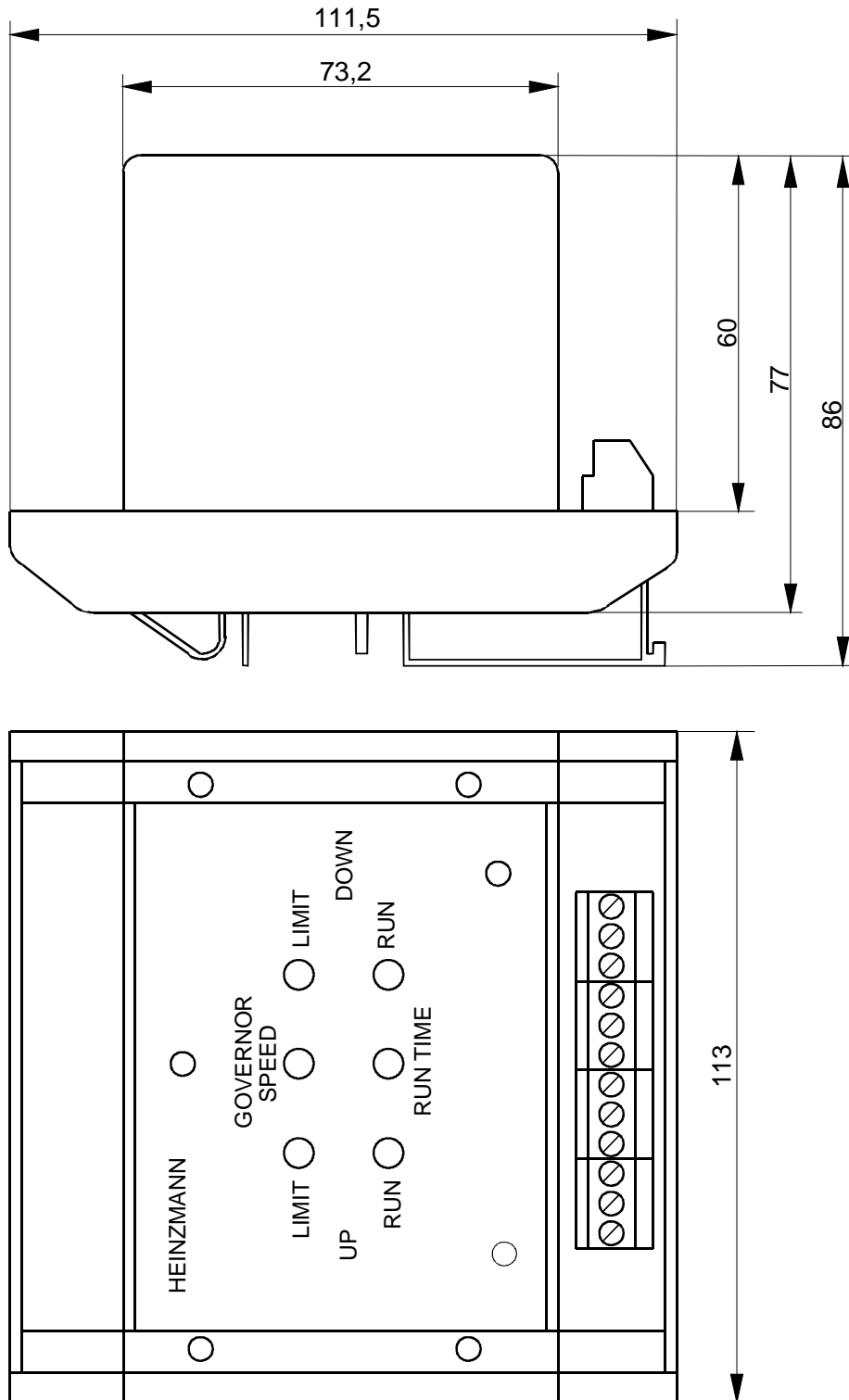

Figure 8: Dimensions of ESW 01 with Plastic Case IP 00

7.2 Metal Case

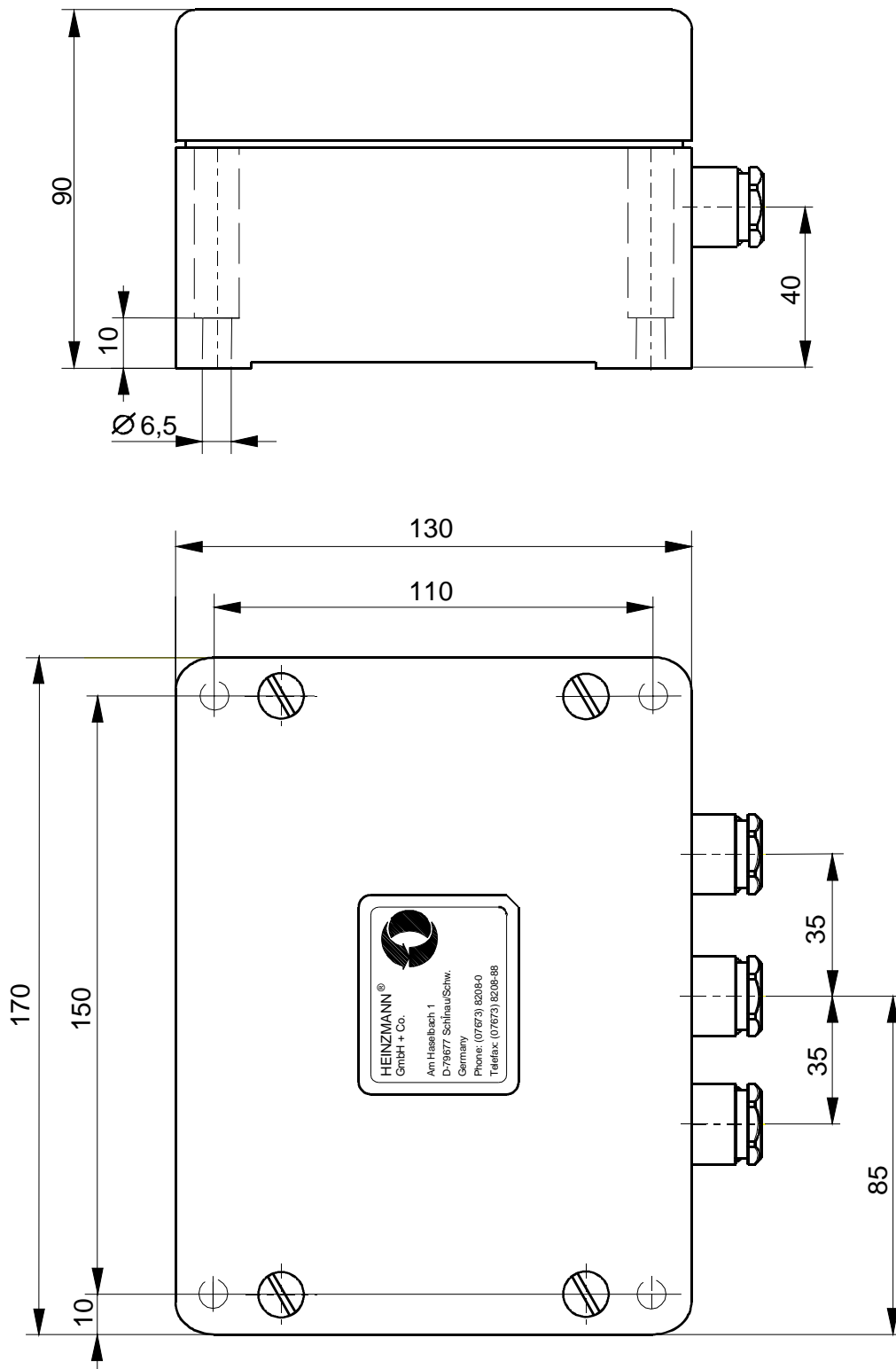

Figure 9: Dimensions of ESW 01 with Metal Case IP 55

8 Adjustment

For setting speed, the ramp function must be deactivated. To ensure this, the terminals 10 and 11 are to be bridged.

For generator sets with fixed speed, the minimum speed potentiometer must have been turned fully clockwise. On commissioning installations with an extended range of speed adjustment it is first set to neutral position to use it for setting minimum speed later on.

8.1 Operation and Indication Elements

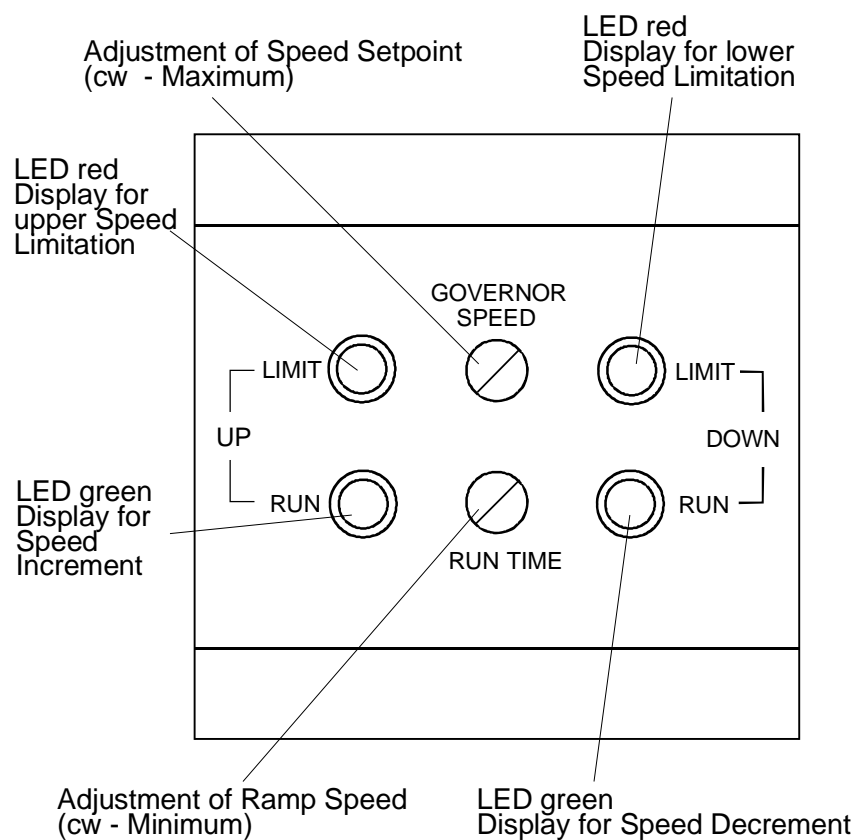

Figure 10: Operation and Indication Elements of ESW 01

8.2 Adjustment of Installations without Manual Potentiometer

Make an external link between terminal 10 and 11 at ESW 01.

Presetting of the stationary engine can be conducted using the HEINZMANN test unit PG 01. On selecting the operating mode engine simulation, speed can be set by means of the potentiometer GOVERNOR SPEED of the ESW 01.

If no test unit PG 01 is available, the potentiometer SPEED of the ESW 01 must be turned counterclockwise to its leftmost stop (minimum speed) prior to starting the engine.

Follow the operating instructions of the respective governor basis system and practice all safety requirements (overspeed protection) when starting the engine.

Turn the potentiometer GOVERNOR SPEED of the ESW 01 clockwise until rated speed is attained.

Turn the potentiometer RUN TIME of the ESW 01 clockwise to its stop (minimum ramp time).

After that, the connection of terminals 10 and 11 may be removed and the ramp function tested. With closing a potentialfree contact between terminals 7 and 8 the speed has to increase and with closing the contacts between terminals 8 and 9 the speed has to decrease. The end of the adjusting range is indicated by red LEDs "LIMIT UP" and "LIMIT DOWN". The closing of the switches is indicated by green LEDs.

Using the potentiometer RUN TIME you can now set the desired speed adjustment rate.



Note

During engine start up at gensets it is recommended to link the terminals 10 and 11 up to the synchronizing request. Then the engine will start exactly with rated frequency.

8.3 Adjustment of Installations with Manual Potentiometer

Make an external link between terminal 10 and 11 at ESW 01.

The potentiometer GOVERNOR SPEED of the ESW 01 must be fully turned to its rightmost stop.

Presetting of the stationary engine can be conducted using the HEINZMANN test unit PG 01. On selecting the operating mode engine simulation, speed can be set by means of the manual potentiometer.

If no test unit PG 01 is available, the manual potentiometer must be turned anticlockwise to its leftmost stop (minimum speed) prior to starting the engine.

Follow the operating instructions of the respective governor basis system and practice all safety requirements (overspeed protection) when starting the engine.

Set rating speed by means of the manual potentiometer.

Turn the potentiometer RUN TIME of the ESW 01 clockwise to its stop (maximum ramp time).

After that, the connection of terminals 10 and 11 may be removed and the ramp function tested. With closing a potentialfree contact between terminals 7 and 8 the speed has to increase and with closing the contacts between terminals 8 and 9 the speed has to decrease. The end of the adjusting range is indicated by red LEDs "LIMIT UP" and "LIMIT DOWN". The closing of the switches is indicated by green LEDs.

Using the potentiometer RUN TIME you can now set the desired speed adjustment rate.



Note

During engine start up at gensets it is recommended to link the terminals 10 and 11 up to the synchronizing request. Then the engine will start exactly with rated frequency.

9 Order Specifications

The order specification for the Electronic Setpoint Potentiometer with plastic case (standard model IP 00) is:

ESW 01-1 (for generator installations)

ESW 01-2 (for heat pumps)

Additional specifications (if required):

- Metal case (IP 55)
- Adjustment time if different from standard versions
- Variation of speed or setpoint voltage if different from standard versions

10 Figure List

Figure 1: Functional Block Diagram ESW 01	6
Figure 2: Wiring of ESW 01 for E 1-F and E 2-F.....	8
Figure 3: Wiring of ESW 01 for E 1-F and E 2-F with Additional Manual Potentiometer.....	9
Figure 4: Wiring of ESW 01 for E 6 to E 40.....	10
Figure 5: Wiring of ESW 01 for E 6 to E 40 with Additional Manual Potentiometer.....	10
Figure 6: Wiring of ESW 01 for E 2000	11
Figure 7: Wiring of ESW 01 for E 2000 with Additional Manual Potentiometer	11
Figure 8: Dimensions of ESW 01 with Plastic Case IP 00	12
Figure 9: Dimensions of ESW 01 with Metal Case IP 55.....	13
Figure 10: Operation and Indication Elements of ESW 01.....	14

11 Order Specifications for Manuals

There is no charge for our technical manuals ordered in reasonable quantities.

Order the necessary manuals on our speed governors from your nearest

[HEINZMANN location](#).

(Please click on “HEINZMANN location” to see the list of our subsidiaries and agents in the world).

Please include the following information:

- your name,
- the name and address of your company (you can simply include your business card),
- the address where you want the manuals sent (if different from above),
- the number(s) (as on front page bottom right) and title(s) of the desired manual(s),
- or the technical data of your HEINZMANN equipment,
- the quantity you want.

You can directly use the following fax-form for ordering one or several manuals.

We solicit comments about the content and the presentation of our publications. Please, send your comments to:

HEINZMANN GmbH & Co. KG

Service Department

Am Haselbach 1

D-79677 Schönau

Germany

Fax Reply

Order for HEINZMANN technical manuals

Fax-Hotline +49 7673 8208 194

Please send me the following manuals:

Quantity	No. of the manual	Title

Please send me your new sales documentation about

() the HEINZMANN Analogue Governors Application:.....

() the HEINZMANN Digital Governors Application:.....

() the HEINZMANN Gas Engine Equipment Application:.....

Company

Contact Person.....

Department

Address..... Country/Code/Town.....

Phone..... Fax.....

E-Mail.....

Activity.....

Date