



Heinzmann GmbH & Co. KG
Engine & Turbine Controls

Am Haselbach 1
D-79677 Schönau (Schwarzwald)
Germany





Phone +49 7673 8208-0
Fax +49 7673 8208-188
E-mail info@heinzmann.com
www.heinzmann.com



V.A.T. No.: DE145551926

HEINZMANN®
Electronic Speed Governors

Power Unit with Emergency Supply Unit

NG 08 + NSV 05

 Warning	<p>Read this entire manual and all other publications appertaining to the work to be performed before installing, operating or servicing your equipment.</p> <p>Practice all plant and safety instructions and precautions.</p>
 Danger	<p>Failure to follow instructions may result in personal injury and/or damage to property.</p> <p>HEINZMANN will refuse all liability for injury or damage which results from not following instructions</p>
 Danger! High Voltage  Danger	<p>Please note before commissioning the installation:</p> <p>Before starting to install any equipment, the installation must have been switched dead!</p> <p>Be sure to use cable shieldings and power supply connections meeting the requirements of the <i>European Directive concerning EMI</i>.</p> <p>Check the functionality of the existing protection and monitoring systems.</p>
 Danger	<p>To prevent damages to the equipment and personal injuries, it is imperative that the following monitoring and protection systems have been installed:</p> <p>Overspeed protection acting independently of the speed governor</p> <p>Overtemperature protection</p> <p>HEINZMANN will refuse all liability for damage which results from missing or insufficiently working overspeed protection</p> <p>Generator installation will in addition require:</p> <p>Overcurrent protection</p> <p>Protection against faulty synchronization due to excessive frequency, voltage or phase differences</p> <p>Reverse power protection</p>
	<p>Overspeeding can be caused by:</p> <p>Failure of the voltage supply</p> <p>Failure of the actuator, the control unit or of any accessory device</p> <p>Sluggish and blocking linkage</p>

 <p>Warning</p>	<p>Electronically controlled injection (MVC) will in addition require to observe the following:</p> <p>With Common Rail systems a separate mechanical flow limiter must be provided for each injector pipe.</p> <p>With Pump-Pipe-Nozzle (PPN) and Pump Nozzle (PNE) systems fuel release may be enabled only by the movement of control piston of the solenoid valve. This is to inhibit fuel from being delivered to the injection nozzle in case of seizure of the control piston.</p>
 <p>Warning</p>	<p>The examples, data and any other information in this manual are intended exclusively as instruction aids and should not be used in any particular application without independent testing and verification by the person making the application.</p>
 <p>Danger</p>	<p>Independent testing and verification are especially important in any application in which malfunction might result in personal injury or damage to property.</p>
	<p>HEINZMANN make no warranties, express or implied, that the examples, data, or other information in this volume are free of error, that they are consistent with industry standards, or that they will meet the requirements for any particular application.</p>
	<p>HEINZMANN expressly disclaim the implied warranties of merchantability and of fitness for any particular purpose, even if HEINZMANN have been advised of a particular purpose and even if a particular purpose is indicated in the manual.</p>
	<p>HEINZMANN also disclaim all liability for direct, indirect, incidental or consequential damages that result from any use of the examples, data, or other information contained in this manual.</p>
	<p>HEINZMANN make no warranties for the conception and engineering of the technical installation as a whole. This is the responsibility of the user and of his planning staff and specialists. It is also their responsibility to verify whether the performance features of our devices will meet the intended purposes. The user is also responsible for correct commissioning of the total installation.</p>

Contents

	Page
1 Safety Instructions and Related Symbols.....	1
1.1 Basic Safety Measures for Normal Operation.....	2
1.2 Basic Safety Measures for Servicing and Maintenance	2
1.3 Before Putting an Installation into Service after Maintenance and Repair Works.....	3
2 General Remarks.....	4
3 Technical Data	5
3.1 Power Supply.....	5
3.2 Battery Set	6
4 Function Mode.....	7
5 Electric Connection	8
6 Arrangement of Alarm Signals	9
7 Measurements.....	10
7.1 Power Supply in Housing.....	10
7.2 Build-in Power Supply	11
7.3 Battery Set	12
8 Calibration	13
9 Maintenance.....	13
10 Odering Specification.....	14
11 Order Specifications for Manuals.....	15

1 Safety Instructions and Related Symbols

This publication offers wherever necessary practical safety instructions to indicate inevitable residual risks when operating the engine. These residual risks imply dangers to

persons

product and engine

environment.

The symbols used in this publication are in the first place intended to direct your attention to the safety instructions!



Warning

This symbol is to indicate that there may exist dangers to the engine, to the material and to the environment.



Danger

This symbol is to indicate that there may exist dangers to persons. (Danger to life, personal injury))



Danger!
High
Voltage

This symbol is to indicate that there exist particular danger due to electrical high tension. (Mortal danger).



Note

This symbol does not refer to any safety instructions but offers important notes for better understanding the functions that are being discussed. They should by all means be observed and practiced. The respective text is printed in italics.

The primary issue of these safety instructions is to prevent personal injuries!

Whenever some safety instruction is preceded by a warning triangle labelled “Danger” this is to indicate that it is not possible to definitely exclude the presence of danger to persons, engine, material and/or environment.

If, however, some safety instruction is preceded by the warning triangle labelled “Caution” this will indicate that danger of life or personal injury is not involved.

The symbols used in the text do not supersede the safety instructions. So please do not skip the respective texts but read them thoroughly!

In this publication the Table of Contents is preceded by diverse instructions that among other things serve to ensure safety of operation. It is absolutely imperative that these hints be read and understood before commissioning or servicing the installation.

1.1 Basic Safety Measures for Normal Operation

- The installation may be operated only by authorized persons who have been duly trained and who are fully acquainted with the operating instructions so that they are capable of working in accordance with them.
- Before turning the installation on please verify and make sure that
 - only authorized persons are present within the working range of the engine;
 - nobody will be in danger of suffering injuries by starting the engine.
- Before starting the engine always check the installation for visible damages and make sure it is not put into operation unless it is in perfect condition. On detecting any faults please inform your superior immediately!
- Before starting the engine remove any unnecessary material and/or objects from the working range of the installation/engine.
- Before starting the engine check and make sure that all safety devices are working properly!

1.2 Basic Safety Measures for Servicing and Maintenance

- Before performing any maintenance or repair work make sure the working area of the engine has been closed to unauthorized persons. Put on a sign warning that maintenance or repair work is being done.
- Before performing any maintenance or repair work switch off the master switch of the power supply and secure it by a padlock! The key must be kept by the person performing the maintenance and repair works.
- Before performing any maintenance and repair work make sure that all parts of engine to be touched have cooled down to ambient temperature and are dead!
- Refasten loose connections!
- Replace at once any damaged lines and/or cables!
- Keep the cabinet always closed. Access should be permitted only to authorized persons having a key or tools.

- Never use a water hose to clean cabinets or other casings of electric equipment!

1.3 Before Putting an Installation into Service after Maintenance and Repair Works

- Check on all slackened screw connections to have been tightened again!
- Make sure the control linkage has been reattached and all cables have been reconnected.
- Make sure all safety devices of the installation are in perfect order and are working properly!

2 General Remarks

HEINZMANN electronic governors with higher output torques (from 64 Nm) require a higher voltage to the output stage to attain the necessary adjustment speed of the actuator; the rest of the electronic needs a normal voltage supply of 24V.

These voltages are provided by the power unit with emergency power supply NG 08 + NSV 05. The power supply may be used for feeding one governor DG 1801 or two governors DG 641 or DG 901.

This unit should be used for applications that require interrupt-free continuation of the governor's operation in case of mains failure (e.g., marine applications).

If the emergency supply is not necessary, the standard power supply NG 09 may be used.

The power supply is available in two versions: without housing for build-in applications and with housing for stand-alone applications. The battery set will be delivered separately and must be mounted in a housing, if necessary.

3 Technical Data

3.1 Power Supply

Voltage input		3 x 400 V ± 10% phase/phase or 3 x 440 V ± 10% phase/phase more voltages available on request
Frequency		50/60 Hz
Power input		750 VA
Output voltage in mains operation		27 V DC and 40 V DC
Residual ripple		< 10%
Output voltage in battery operation		24 V DC and 36 V DC
Output current		
	24/27 V- range	max. 2 x 2 A
	36/40 V- range	max. 12,5 A
Temperature range		- 20 °C to + 60 °C
Humidity		up to 90 %
Alarms		Phase error / supply failure Charging error Battery voltage too low
Contact rating of alarm relais		2 A at 380 V AC 5 A at 250 V AC 5 A at 30 V DC
Protection grade	build-in unit in housing	IP 00 IP 55
Weight	build-in unit in housing	approx. 26 kg approx. 37 kg

3.2 Battery Set

Battery voltage	3 x 12 V
Battery capacity	12,5 Ah
Battery life target	
200 cycles	with 100% discharge
700 cycles	with 60% discharge
for fully charged state	up to 8 years
Temperature range	- 20 °C to + 45 °C short-term up to + 55°C
Humidity	up to 90 %
Protection grade	IP 00
Weight	approx. 26 kg

4 Function Mode

By means of the power unit with emergency supply NG 08 + NSV 05, three-phase supply voltage is reduced by transformers to lower voltage and converted into DC voltage by a bridge rectifier. A downstream stabilized voltage regulator and a voltage limiter ensure constant output voltage.

In case of mains failure, an interrupt-free change-over to battery operation is automatically carried out. During normal operation, the battery is kept in charged state by a charging device.

By an alarm system, any occurring faults are indicated and transmitted to a control centre (bridge in case of ships). Alarms are indicated in order to spare the battery, but only if the governor switch is turned on.

The following alarms are issued:

- Battery voltage too low
- Battery charging
- Mains or battery operation



Warning

In case of mains disconnection, the governor switch is to be set to „Off“ in order to avoid discharging the battery!

5 Electric Connection

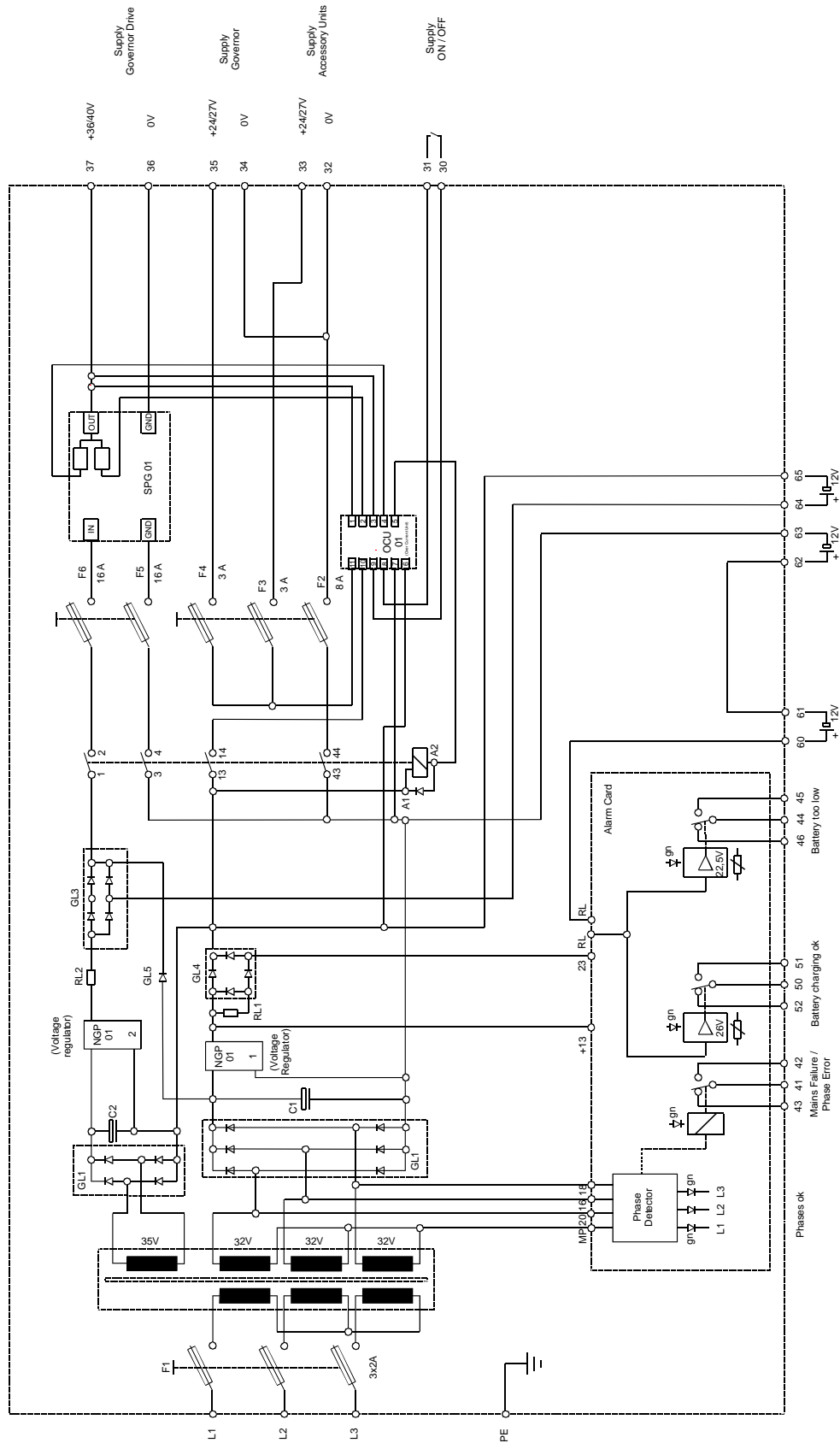

Figure 1: Electric Connection
Power Supply NG 08 + NSV 05

6 Arrangement of Alarm Signals

Battery voltage

Battery charge

Mains operation

Phase L1

Phase L2

Phase L3

LED 5 ● red

LED 6 ● green

LED 4 ● green

LED 1 ● green

LED 2 ● green

LED 3 ● green

Alarm panel

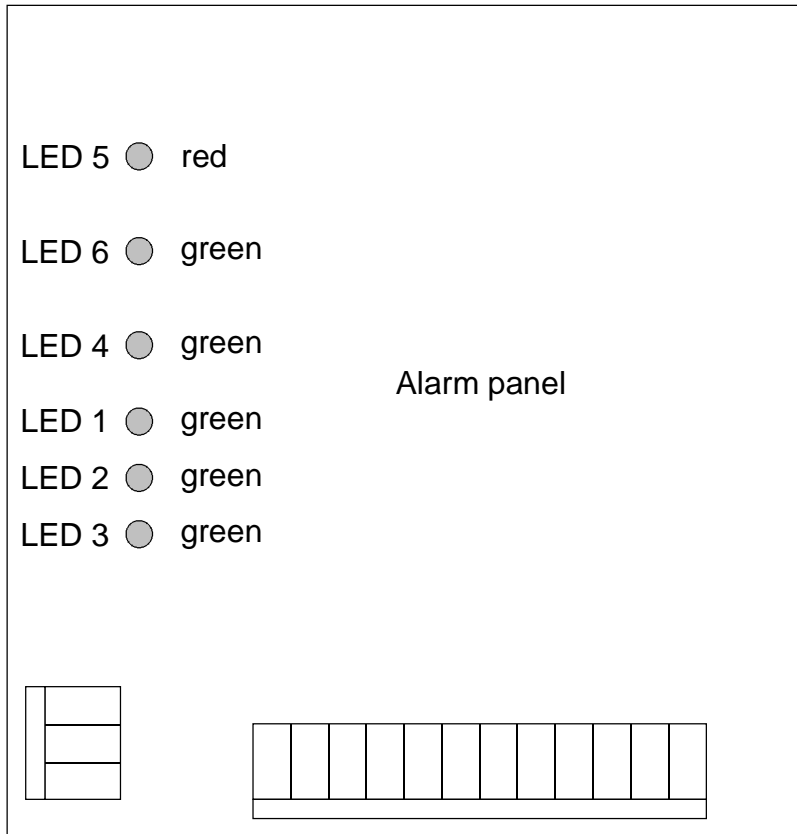

Figure 2: Arrangement of Alarm Signals

7 Measurements

7.1 Power Supply in Housing (EDV- No.: 600 00 033 00)

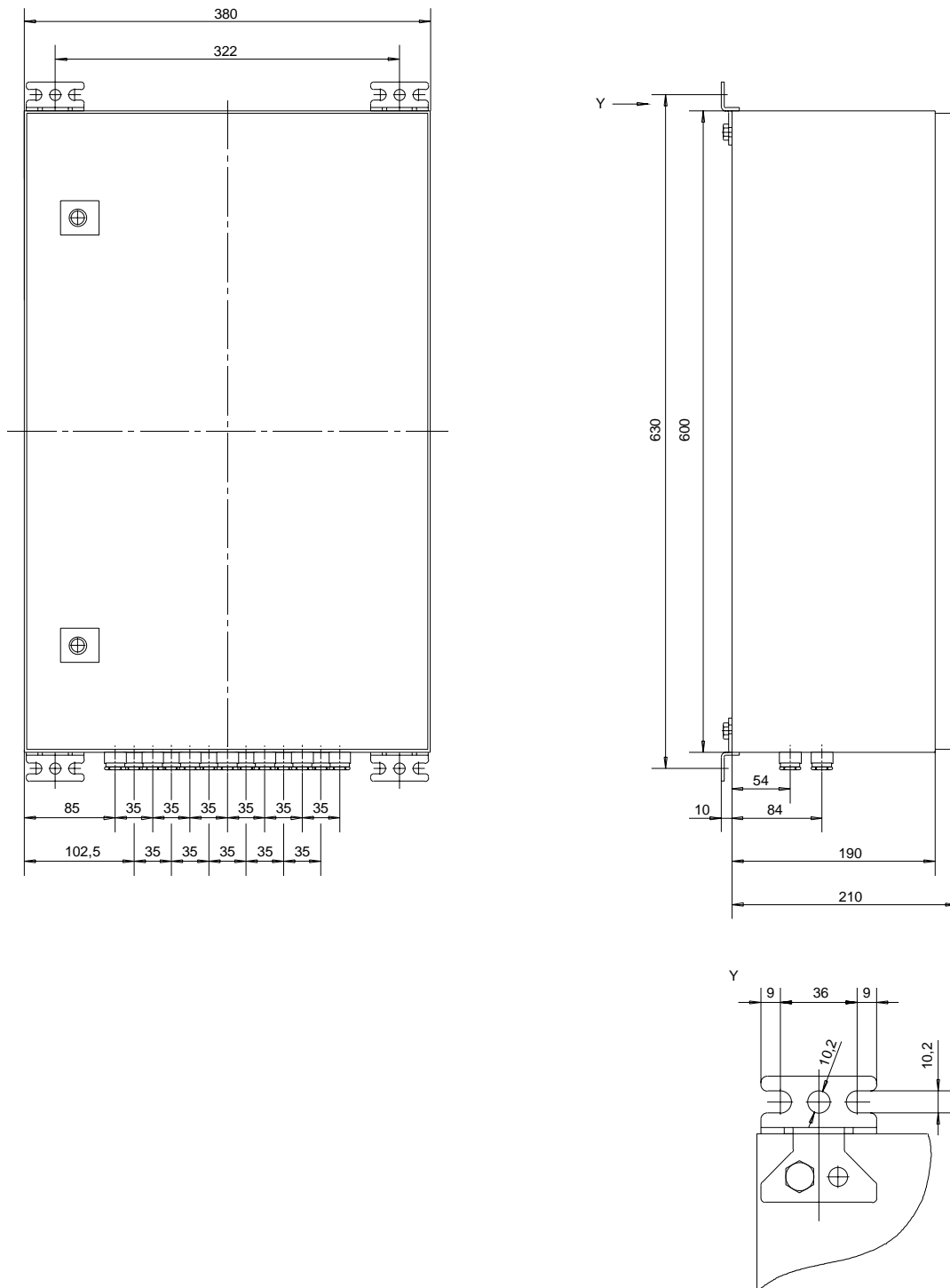

Figure 3: Dimensional Drawing of Power Supply in Housing

7.2 Build-in Power Supply (EDV-No.: 600 80 008 00)

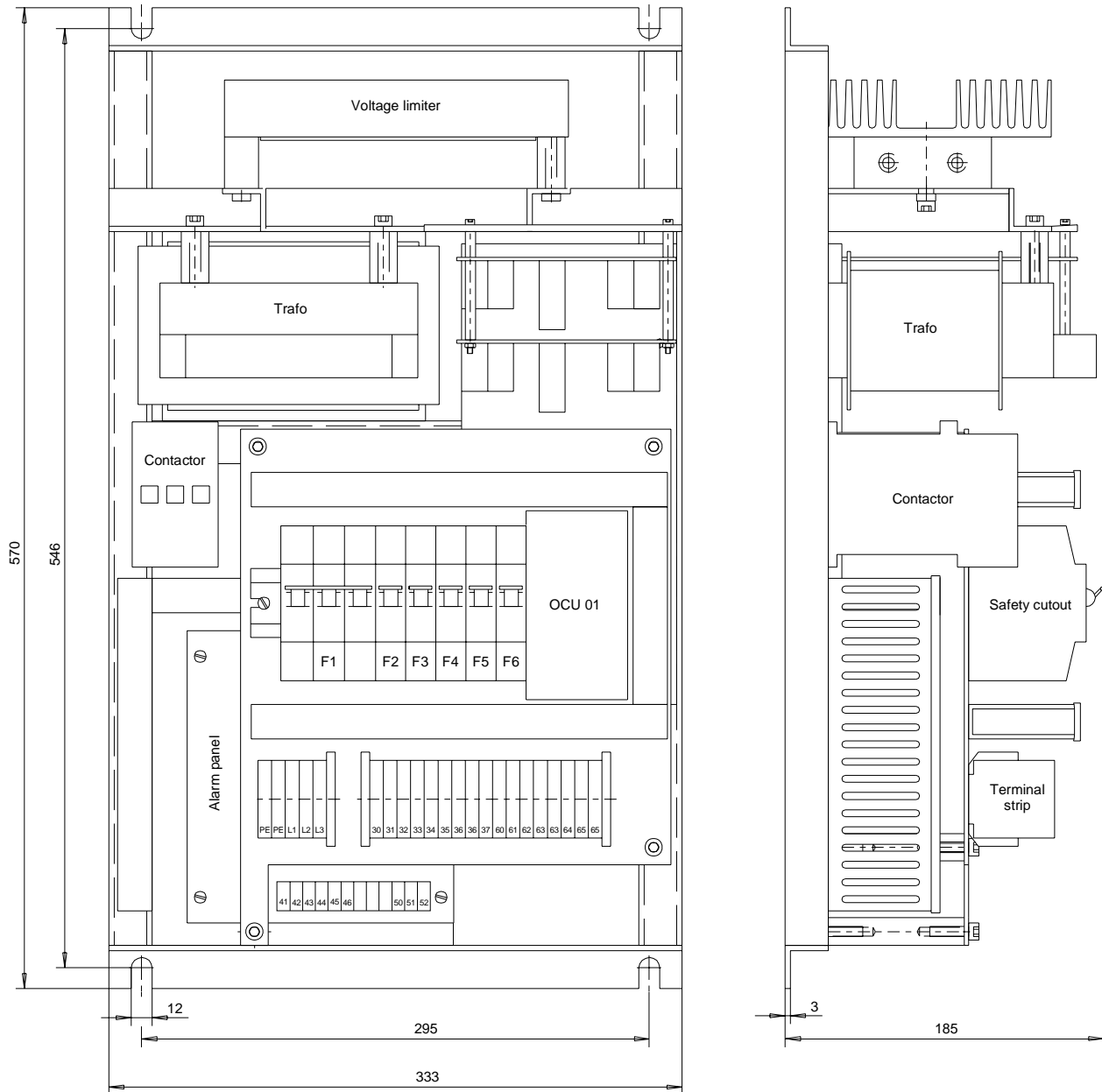

Figure 4: Dimensional Drawing of Build-in Power Supply

7.3 Battery Set (EDV- No.: 600 00 032 00)

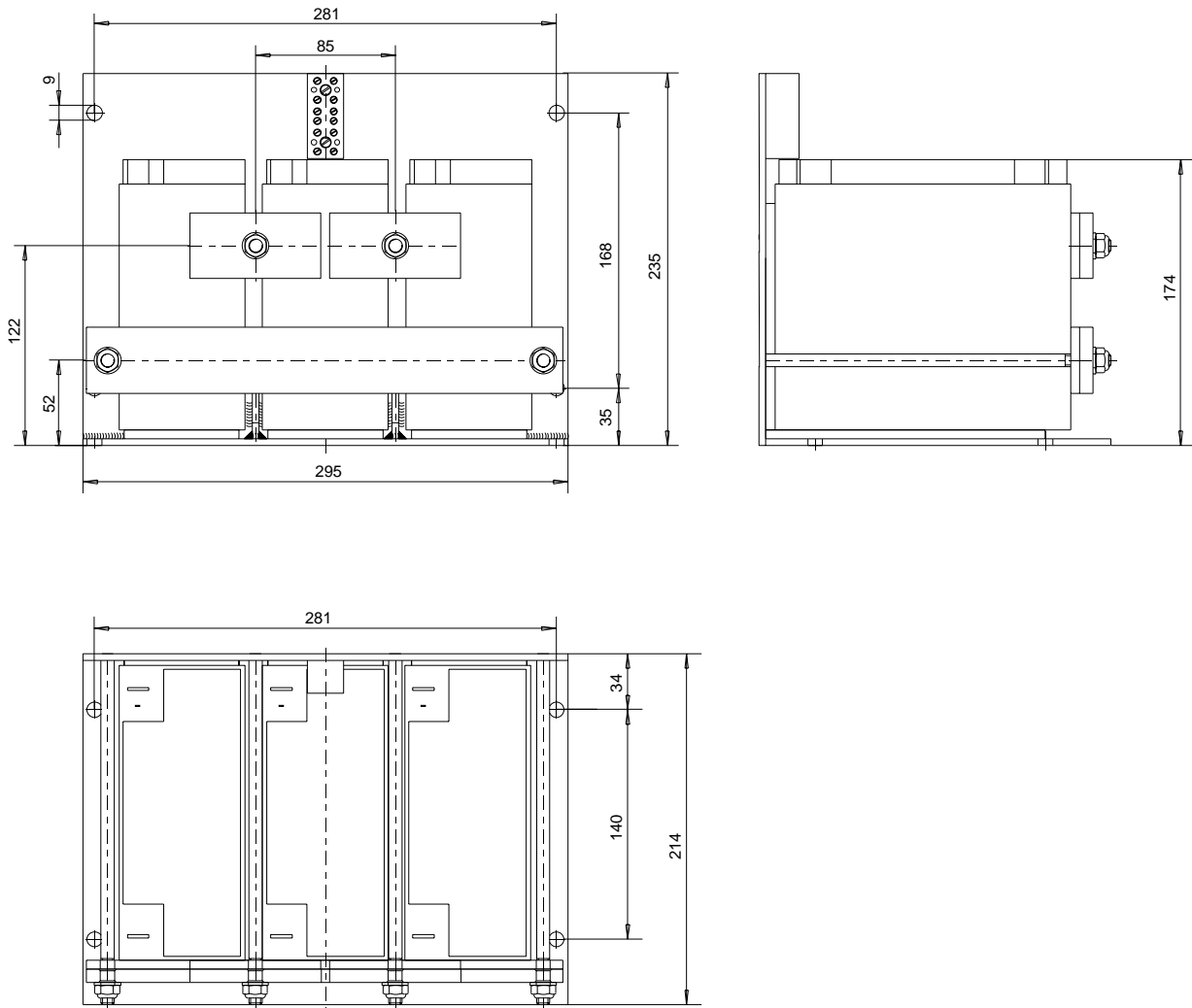

Figure 5: Dimensional Drawing of Battery Set

8 Calibration

The device has been calibrated in the factory; there is neither need for further calibration nor should any such adjustment be carried out.

9 Maintenance

Both the power unit and the battery are maintenance-free. The batteries, however, must regularly be checked for their state.

To do so, it is required every three month to change over to battery operation for 40 minutes after at least 24 hours of normal operation (the fuses will have to be removed).

It will be necessary to exchange the batteries, if during this time the alarm „battery voltage too low“ is issued.

When the batteries need to be changed, the complete battery set has to be re-newed. It is not allowed to change single batteries.



Warning

In case of mains disconnection, the governor switch is to be set to „Off“ in order to avoid discharging the battery!

10 Ordering Specification

The ordering designation is:

NG 08 + NSV 05

Furthermore, it is requested to give following informations:

- | | |
|--------------------|--------------------------|
| Build-in supply | <input type="checkbox"/> |
| in housing | <input type="checkbox"/> |
| Connection voltage | V |

11 Order Specifications for Manuals

There is no charge for our technical manuals ordered in reasonable quantities.

Order the necessary manuals on our speed governors from your nearest

[HEINZMANN location](#).

(Please click on “HEINZMANN location” to see the list of our subsidiaries and agents in the world).

Please include the following information:

- your name,
- the name and address of your company (you can simply include your business card),
- the address where you want the manuals sent (if different from above),
- the number(s) (as on front page bottom right) and title(s) of the desired manual(s),
- or the technical data of your **HEINZMANN** equipment,
- the quantity you want.

You can directly use the following fax-form for ordering one or several manuals.

Most of the manuals are available as acrobat PDF-files, too. On request they can be send via e-mail.

We solicit comments about the content and the presentation of our publications. Please, send your comments to:

HEINZMANN GmbH & Co. KG

Service Department

Am Haselbach 1

D-79677 Schönau

Germany

Fax Reply

Order for HEINZMANN technical manuals

Fax-Hotline +49 7673 8208 194

Please send me the following manuals:

Quantity	No. of the manual	Title

Please send me your new sales documentation about

- () the HEINZMANN Analogue Governors Application:.....
- () the HEINZMANN Digital Governors Application:.....
- () the HEINZMANN Gas Engine Equipment Application:.....

Company

Contact Person.....

Department.....

Address..... Country/Code/Town.....

Phone..... Fax.....

E-Mail.....

Activity.....

Date