

DK/StG 3-PD

DK/StG 3⁺-PD

DATA SHEET

Description

Combining the StG 3-PD positioner with a throttle valve, these devices are ideal for use as part of the control of gas or dual-fuel engines. The throttle valves are available with several cross-sections. The design is suitable for many gas types such as natural gas, landfill gas, biogas, or propane. An admixture of H₂ up to 30 % is permissible.

Controlled by standard voltage, current or PWM signals the positioners also have CAN communication.

Their robust and enduring design also makes the device applicable without restriction for mobile heavy-duty applications.

Uniformly strong torques over the entire range of adjustment are enabled by the special design of the solenoid system.

The armature is optimised for lowest heat build-up. Additionally, the design enhances heat transfer to the outside and so allows a wide working temperature range. Optionally the units are available with liquid cooled electronics.

Result of the direct acting mode of operation without gears are extremely short reaction times.

In principle, each device is equipped with a return spring which ensures that a zero position is reached in the event of power supply failure.

Application of special materials and long-duration lubricants assure maintenance-free operation and long service life. Mounting of the device is possible in any fitting position. The robust and enduring design with IP6K9K degree of protection allows operation under roughest ambient conditions.

Application range

- Small and medium-sized diesel or gas engines
- Gas and steam turbines

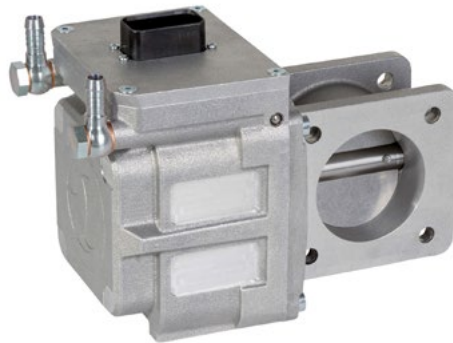

Features

Direct acting without gears

Quick response time

Enhanced service life due to optimised bearing

Working temperature range up to 150 °C possible

Suitable for any gas type (natural gas, landfill gas, biogas, propane), admixture of H₂ up to 30 % possible

Applicable as throttle valve as well as turbo bypass

Certificates

On request: CSA, ATEX, marine approval

Technical data

Positioner	DK/StG 3-PD	DK/StG 3+-PD
Mode of operation	4Q	4Q
Angle of rotation	72°	72°
Max. torque without return spring	approx. 3 Nm	approx. 6 Nm
Torque in steady state without return spring	approx. 1.5 Nm	approx. 3 Nm
Torque of return spring	0.50 ... 0.82 Nm	0.50 ... 0.82 Nm
No load response time (depending on controller)	< 40 ms	< 40 ms
Working voltage of armature	nom. 24 VDC 18 ... 32 VDC	nom. 24 VDC 18 ... 32 VDC *)
Max. permissible current consumption	6 A	6 A
Max. permissible current in steady state	3 A	3 A
Power supply position sensor	5 ±0.1 VDC	5 ±0.1 VDC
Position signal (0 ... 100 %)	0.5 ... 4.5 V	0.5 ... 4.5 V
Degree of protection / actuator	IP6K9K	IP6K9K
Degree of protection / plug	IP67	IP67
Weight	approx. 5.5 kg	approx. 5.5 kg
Ambient temperature	-20 ... +100 °C	-20 ... +100 °C

*) with voltage supply < 24 VDC temperature-related derating of maximum torque

Pin assignment

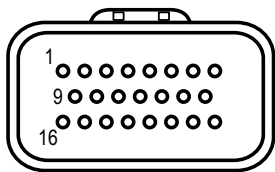

TYCO 23-pin,
coding-1,
view on plug side

Pin	Signal	Signal type
1	Power supply (+)	24 V
2	Auxiliary power out	24 V, max. 0.7 A
3	RS-232 TX	Communication
4	Analogue input (+) for setpoint	4 ... 20 mA or 0 ... 4.5 V Type selection via pin 19
5	Digital input 1 *)	open: run enable low side: stop (standard)
6	PWM shield	-
7	Digital input 2 *)	binary
8	Power output	5 V, max. 50 mA
9	Trottle position feedback, analogue output	0.5 ... 4.5 V
10	Digital input 4 isolated (-)	PWM or binary
11	RS-232 RX	Communication
12	GND	0 V
13	CAN high	Communication
14	CAN shield	-
15	GND	0 V
16	Power supply (-)	0 V
17	GND	0 V
18	Digital input 4 isolated (+)	PWM
19	Type selection of analogue input pin 4	connected to pin 20 (GND): 4 ... 20 mA open: 0.5 ... 4.5 V"
20	Analogue input 1 GND	0 V
21	CAN low	Communication
22	Digital input 3 *)	binary
23	Status output	binary

*) Activation type configurable globally, high side or low side. Default: low side

Characteristic curves

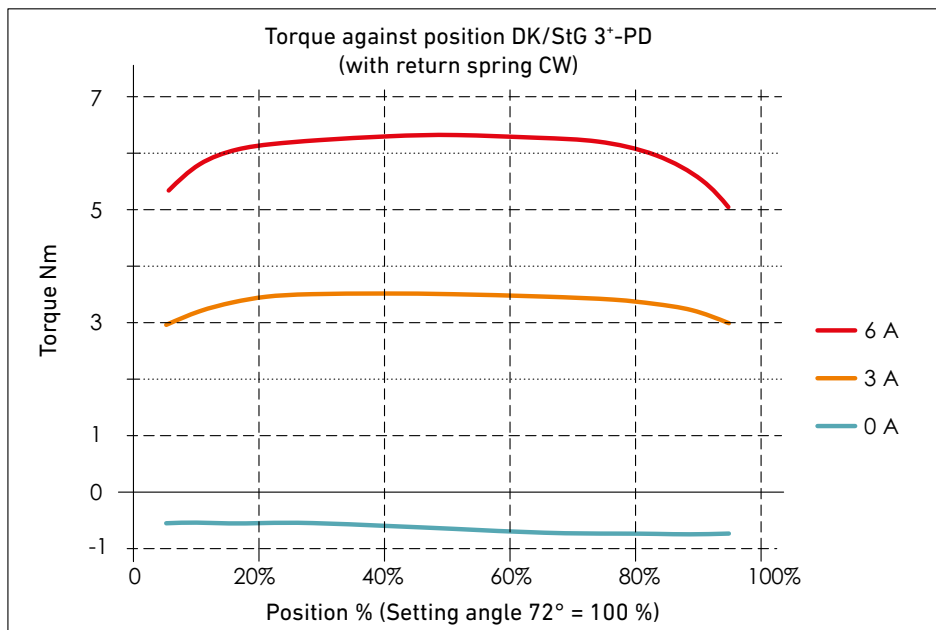
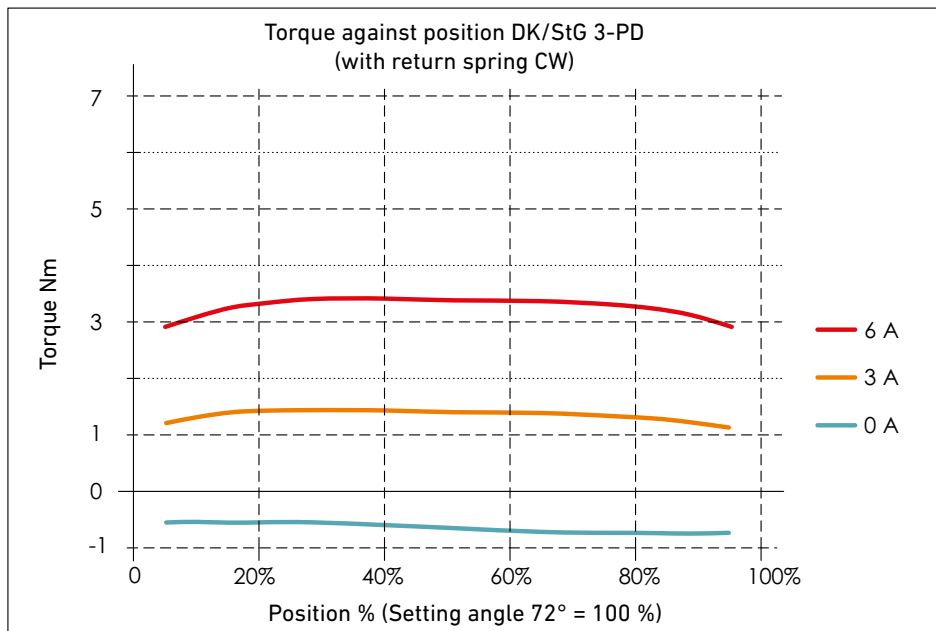
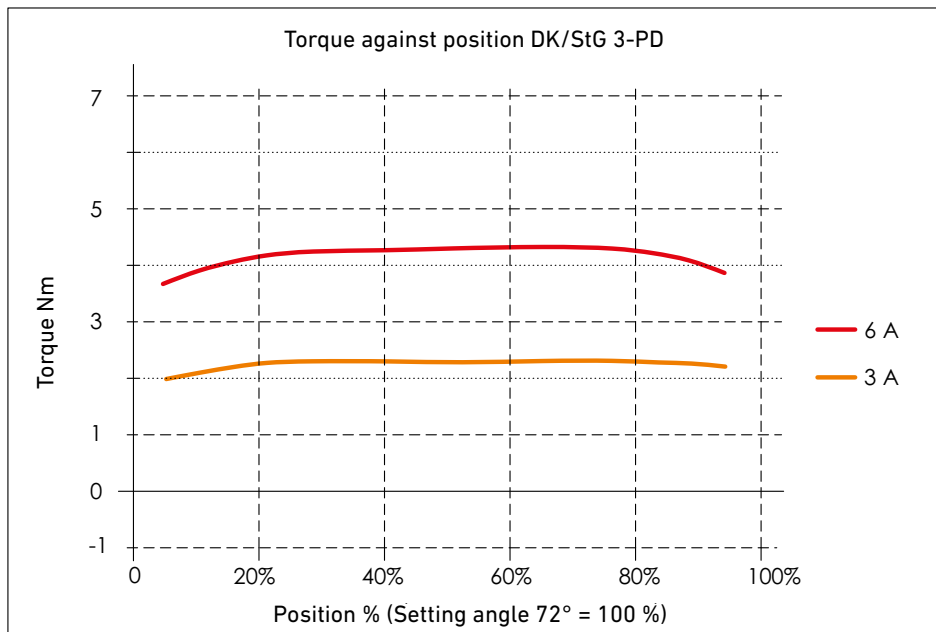

Technical data

Throttle valve	DK 100	DK 200 *)
Diameter	Ø 48, 60 and 68 mm	Ø 80, 90, 100 and 110 mm
Engine power **)	approx. 50 ... 250 kW	approx. 100 ... 350 kW
Permissible gas pressure max.	5.8 bar (abs.)	4 bar (abs.)

*) Version with enhanced operating temperature available on request

***) Power range for naturally aspirated engines. For turbo charged engines 50% up to 150 % higher, depending on boost pressure. Variants on request.

Dimensions

DK 100 / StG 3-PD; DK 100 / StG 3+-PD

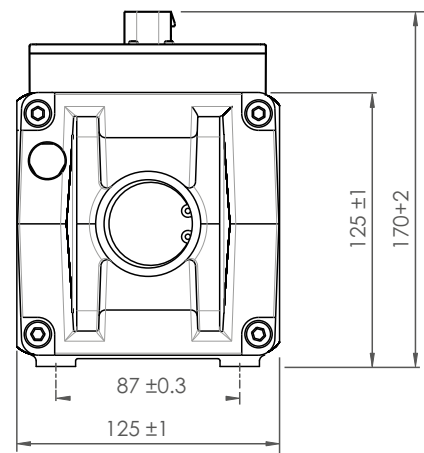
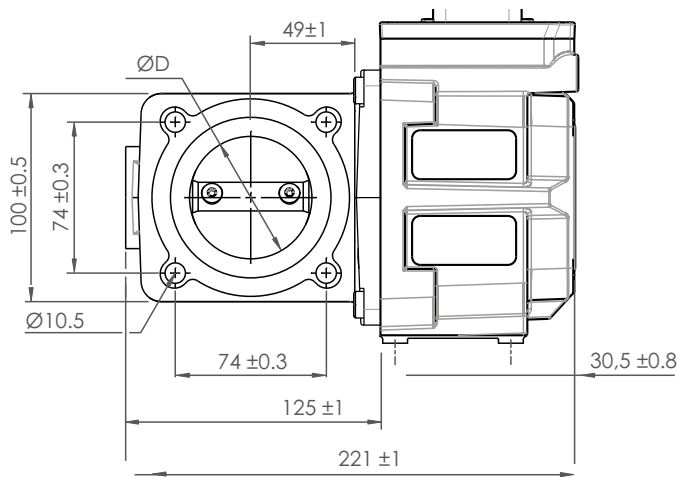

DK 100 - gasket, article no.: 462-24-001-00

DK 200 / StG 3+-PD

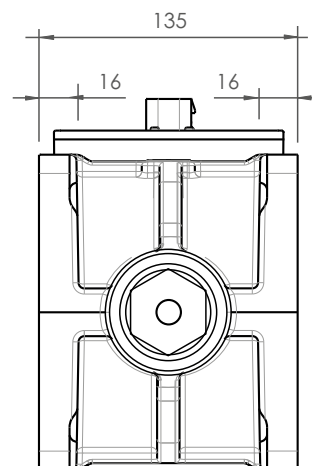
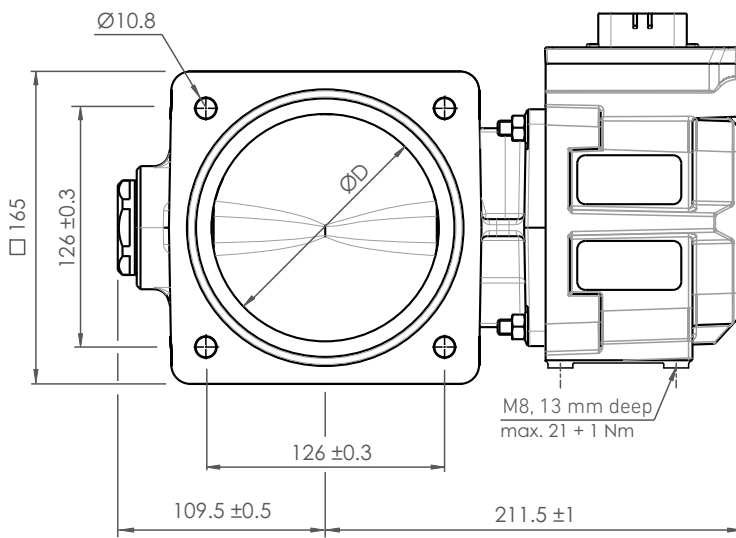

DK 200- o-ring, article no.: 001-12-204-00