

GMCU-II-110-FC

DATA SHEET

Description

The ELEKTRA Gas Metering Control Unit GMCU-II-110-FC serves as main component of a full authority gas engine management system. A flow setpoint specified via CAN bus leads to precise adjusting of the according gas flow to a gas mixer.

Based on the measurement values of differential pressure, gas pressure and temperature the gas throttle valve, directly mounted on a StG 3 actuator, is controlled by the integrated control board to achieve the desired gas flow rate.

Precise calibration of the gas metering unit combined with a high-accuracy valve actuator enables the unit to provide outstanding flow control.

Any measuring channels for gas pressures are integral part of the cast housing. The design is extremely robust and the absence of any tubes results in high shock and vibration resistance.

GMCU-II-110-FC is able to handle a differential pressure range of 40 ... 250 mbar.

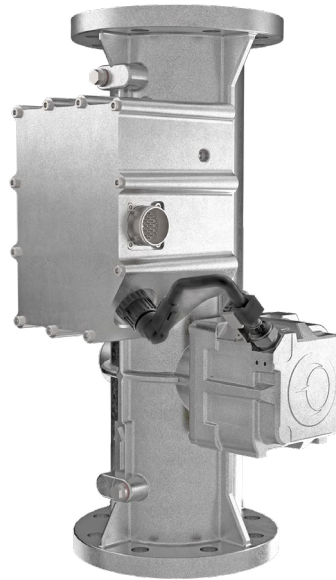

Features

Accurate air-fuel ratio control

Compensation of gas quality fluctuations

Designed for integration into existing AFR control systems

Ideal for retrofitting and large engine OEM applications

Suitable for different gas types and qualities

No zero pressure regulator required

Tolerant to wet biogases and corrosive contaminants

CAN bus communication

Technical data

General specification

Supply voltage	18 ... 32 VDC, nom. 24 VDC
Current consumption	max. 6 A
Gas inlet pressure	500 ... 2000 mbar (abs.)
Pressure difference inlet / outlet	40 ... 250 mbar
Flow accuracy	< 5 % (at min. 15 % of maximum flow)
Operating temperature	-25 ... +85 °C
Storing temperature	-40 ... +100 °C
Permissible ambient humidity	<95 % at 55 °C
Vibration	max. 2 mm at 10 ... 20 Hz max. 0.24 m/s at 21 ... 63 Hz max. 9g at 64 ... 2000 Hz
Degree of protection	IP6K9K
I / O interface	CAN bus

Dimensions

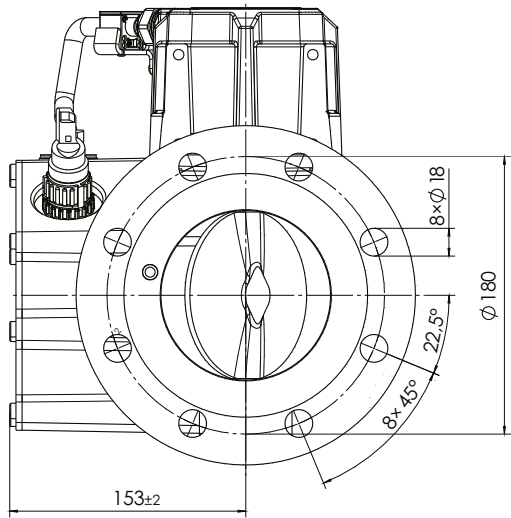

Flange according to
DIN 1092-1 DN100 / PN16

