



**Heinzmann GmbH & Co. KG**  
**Engine & Turbine Management**

Am Haselbach 1  
D-79677 Schönau  
Germany

Phone +49 7673 8208 - 0  
Fax +49 7673 8208 - 188  
E-mail [info@heinzmann.de](mailto:info@heinzmann.de)  
[www.heinzmann.com](http://www.heinzmann.com)

V.A.T. No.: DE145551926

**HEINZMANN®**

**Engine & Turbine Management**

## **Digital Positioning System**

**StG 40.90-09 PD**

### **Instruction manual** **(original instructions)**



**DANGER**

**The appropriate manuals must be thoroughly studied before installation, initial start-up and maintenance.**

All instructions pertaining to the system and safety must be followed in full. Non-observance of the instructions may lead to injury to persons and/or material damage.

HEINZMANN shall not be held liable for any damage caused through non-observance of instructions.

Independent tests and inspections are of particular importance for all applications in which a malfunction could result in injury to persons or material damage.

All examples and data, as well as all other information in this manual are there solely for the purpose of instruction and they may not be used for special application without the operator running independent tests and inspections beforehand.



**HEINZMANN** does not guarantee, neither expressly nor tacitly, that the examples, data or other information in this manual is free from error, complies with industrial standards or fulfils the requirements of any special application.



**WARNING**

**To avoid any injury to persons and damage to systems, the following monitoring and protective systems must be provided:**

- overspeed protection independent of the rpm controller

HEINZMANN shall not be held liable for any damage caused through missing or insufficiently rated overspeed protection.

- thermal overload protection

**The following must also be provided for alternator systems:**

- Overcurrent protection
- Protection against faulty synchronisation for excessively-large frequency, voltage or phase difference
- Directional contactor

The reasons for overspeeding may be:

- Failure of positioning device, control unit or its auxiliary devices
- Linkage sluggishness and jamming



**The following must be observed before an installation:**

- Always disconnect the electrical mains supply before any interventions to the system.
- Only use cable screening and mains supply connections that correspond with the *European Union EMC Directive*
- Check the function of all installed protection and monitoring systems



**Please observe the following for electronically controlled injection (MVC):**

- For **common rail** systems each injector line must be equipped with a separate mechanical flow-rate limiter.
- For **unit pump (PLD)** and **pump-injector unit (PDE)** systems, the fuel enable is first made possible by the solenoid valve's control plunger motion. This means that in the event of the control plunger sticking, the fuel supply to the injection valve is stopped.



As soon as the positioning device receives power, it can actuate the controller output shaft automatically at any given time. The range of the controller shaft or control linkage must therefore be secured against unauthorised access.

**HEINZMANN** expressly rejects any implied guarantee pertaining to any marketability or suitability for a special purpose, including in the event that **HEINZMANN** was notified of such a special purpose or the manual contains a reference to such a special purpose.

**HEINZMANN** shall not be held liable for any indirect and direct damage nor for any incidental and consequential damage that results from application of any of the examples, data or miscellaneous information as given in this manual.

**HEINZMANN** shall not provide any guarantee for the design and planning of the overall technical system. This is a matter of the operator its planners and its specialist engineers. They are also responsible for checking whether the performances of our devices match the intended purpose. The operator is also responsible for a correct initial start-up of the overall system.

---

## Contents

	<b>Page</b>
<b>1 Safety Instructions and Related Symbols .....</b>	<b>1</b>
1.1 Safety Measures for Positioning Devices .....	2
1.2 Safety Measures under Normal Operation .....	3
1.3 Safety Measures for Maintenance and Servicing .....	3
<b>2 Application and Function .....</b>	<b>4</b>
2.1 Proper and intended use .....	4
2.2 Function description .....	4
2.3 Functional Block Diagram .....	6
<b>3 Specifications of Positioning System StG 40.90-09 PD .....</b>	<b>7</b>
3.1 Design and Mode of Operation .....	7
3.2 Electrical Specification .....	8
3.3 Actuator Specification .....	9
3.4 Dimensions .....	10
<b>4 Installation and Regulating Linkage .....</b>	<b>11</b>
4.1 Installation .....	11
4.2 Regulating Linkage .....	11
4.2.1 Length of Lever Arm .....	11
4.2.2 Connecting Linkage .....	11
4.2.3 Linkage Adjustment for Diesel Engines .....	12
4.2.4 Linkage Adjustment for Carburettor Engines .....	13
<b>5 Electrical Connection .....</b>	<b>14</b>
5.1 Pin Assignment .....	14
5.2 Connection of Power Supply .....	14
<b>6 Figure List .....</b>	<b>16</b>
<b>7 Download of Manuals .....</b>	<b>17</b>
<b>8 Declaration of Incorporation .....</b>	<b>18</b>

## 1 Safety Instructions and Related Symbols

This publication offers practical safety instructions to indicate the unavoidable residual risks involved when operating the machine. These residual risks involve hazards to

- Personnel
- Product and machine
- The environment

**The primary aim of the safety instructions is to prevent personal injury!**

The signal words used in this publication are specifically designed to direct your attention to possible damage extent!



**DANGER** *DANGER indicates a hazardous situation the consequence of which could be fatal or severe injuries if it is not prevented.*



**WARNING** *WARNING indicates a hazardous situation which could lead to fatal injury or severe injuries if it is not prevented.*



**CAUTION** *CAUTION indicates a hazardous situation which could lead to minor injuries if it is not prevented.*

**NOTICE**

**NOTICE** *NOTICE indicates possible material damage.*



*Safety instructions are not only denoted by a signal word but also by hazard warning triangles. Red hazard warning triangles indicate immediate danger to life. Yellow hazard warning triangles indicate a possible risk to life and limb. Hazard warning triangles can contain different symbols to illustrate the danger. However, the symbol used is no substitute for the actual text of the safety instructions. The text must therefore always be read in full!*

**In this publication the Table of Contents is preceded by diverse instructions that among other things serve to ensure safety of operation. It is absolutely imperative that these hints be read and understood before commissioning or servicing the installation.**

## 1.1 Safety Measures for Positioning Devices

This machine has been designed for reliable utilisation in accordance with the application, conditions and specifications as described in these instructions. Everyone who works on this machine must have read these instructions and the information. The employer or safety officer bear responsibility for ensuring that these instructions are known and adhered to.



**WARNING**

### High weight of positioning device

#### Risk of crushing or bone injuries caused by device falling down

- > Wear safety shoes when transporting the device
- > Mechanical protection devices against falling down
- > Use suitable hoisting gear



**CAUTION**

### Device gets hot

#### Risk of burn injuries

- > Always allow positioning device to cool down first before working on it
- > Wear suitable protective clothing

**NOTICE**

#### Risk of damage to positioning device through improper use!

- > Installation, maintenance and operation to be conducted by skilled personnel only.
- > Never use a high-pressure cleaner for cleaning the device



## 1.2 Safety Measures under Normal Operation



**The system may be operated by qualified and authorised personnel only, who are both familiar with the operating instructions and who can carry them out!**

**Before switching on the system, check and ensure that:**

- > only authorised personnel are in the machine's operating range
- > no-one can be injured by the machine starting up

**Before each start of the motor:**

- > Always check the system for visible damage and ensure it is not put into operation unless it is in perfect condition! Always notify the responsible department immediately about any defects
- > Check and ensure that all safety devices are in proper working condition
- > Remove all material and objectives surplus to requirements from the operating range of the system or motor

## 1.3 Safety Measures for Maintenance and Servicing



**Before starting maintenance or repair work:**

- > Block off access to the machine's working area for unauthorised persons!  
Put up an information board that indicates that such work is underway
- > Switch off main switch for mains supply and secure with a padlock! The key to the padlock must be held by the person carrying out the maintenance or repair work
- > Ensure that all parts that are capable of being touched have cooled down to ambient temperature and have been isolated from the mains
- > Re-fasten loose connections
- > Replace any damaged lines or cables immediately
- > Keep the switch cabinet closed at all times! Access is solely for authorised persons with key/tools
- > Never use a water spray or high-pressure cleaners on switch cabinets and other electrical equipment enclosures for cleaning purposes! Risk of short circuit and corrosion to positioning device

## **2 Application and Function**

### **2.1 Proper and intended use**

The positioning devices StG 40.90-09 PD is to be used solely for control applications on machines. It is intended for use in an industrial environment. When operated outdoors, additional protective measures against weather are also required.

Signals are exchanged electrically. Because transmission may be interfered with by external circumstances or influences, the user must provide additional safety devices to match the application case.

In individual cases, the following must be coordinated with the manufacturer HEINZMANN:

- Each use which deviates from the above mentioned
- Modifications to the device
- Use in extreme, ambient conditions that deviate from the specification (dust, temperature, wetness)
- Use under powerful electrical or electromagnetic fields
- Use in aggressive atmospheres or vapours
- Use in potentially explosive areas

A written opinion from the manufacturer must always be procured in the event of any obscurities, queries or missing statement.

### **2.2 Function description**

Positioning devices StG 40.90-09 PD is an electrical positioner with a rotating output shaft. It can be used for a wide range of control applications or in combination with superior control systems for control purposes of any kind.

It is actuated by an external, electrical position set point signal, and thereby automatically regulates the mechanical position of its output shaft. The position set point can be transmitted to it as a current, voltage or PWM signal, depending on preattunement.. For operation the device requires a power supply. The use of these positioners, in contrast to where positioning



devices are regulated directly by controllers, can be a practical option when more stringent requirements are placed on control accuracy.

In positioners, there is a proportional correlation between the position of the actuator output shaft and a command input signal. The following curve shows this relation for the 4 – 20 mA input signal exemplary.

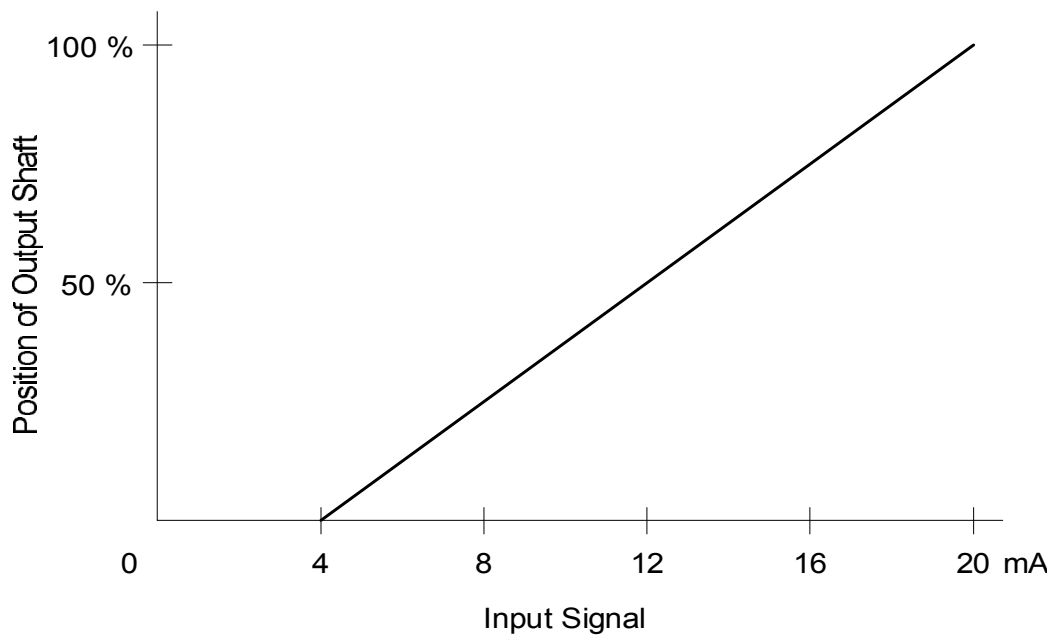

**Figure 1: Example for relation between current input signal and position**

The input signal, i.e. the position setpoint for the actuator output shaft is sent to an actual/setpoint comparator receiving the actual value from the actuator feedback. Subsequent signal processing for position control is performed by a microcontrol.

The position control circuit incorporates a 4-quadrant amplifier which allows to drive the actuator electrically in either direction. This ensures optimum utilization of the actuator's rotational force. Together with very low current consumption in steady state operation heat build-up in the actuator also is reduced.

The feedback signal, i.e. the output shaft position signal, is available as an electrical signal. It can be used as well for further processing as for indicating actuator position.

Due to the programable microcontrol a lot of functions and capabilities of the positioning devices StG 40.90-09 PD can be determined by parameterization. This offers various options for the systems setting up and its configuration.

For instance linear output characteristic, range, type and sense of input and output etc. can be adapted to users requirements.

### 2.3 Functional Block Diagram

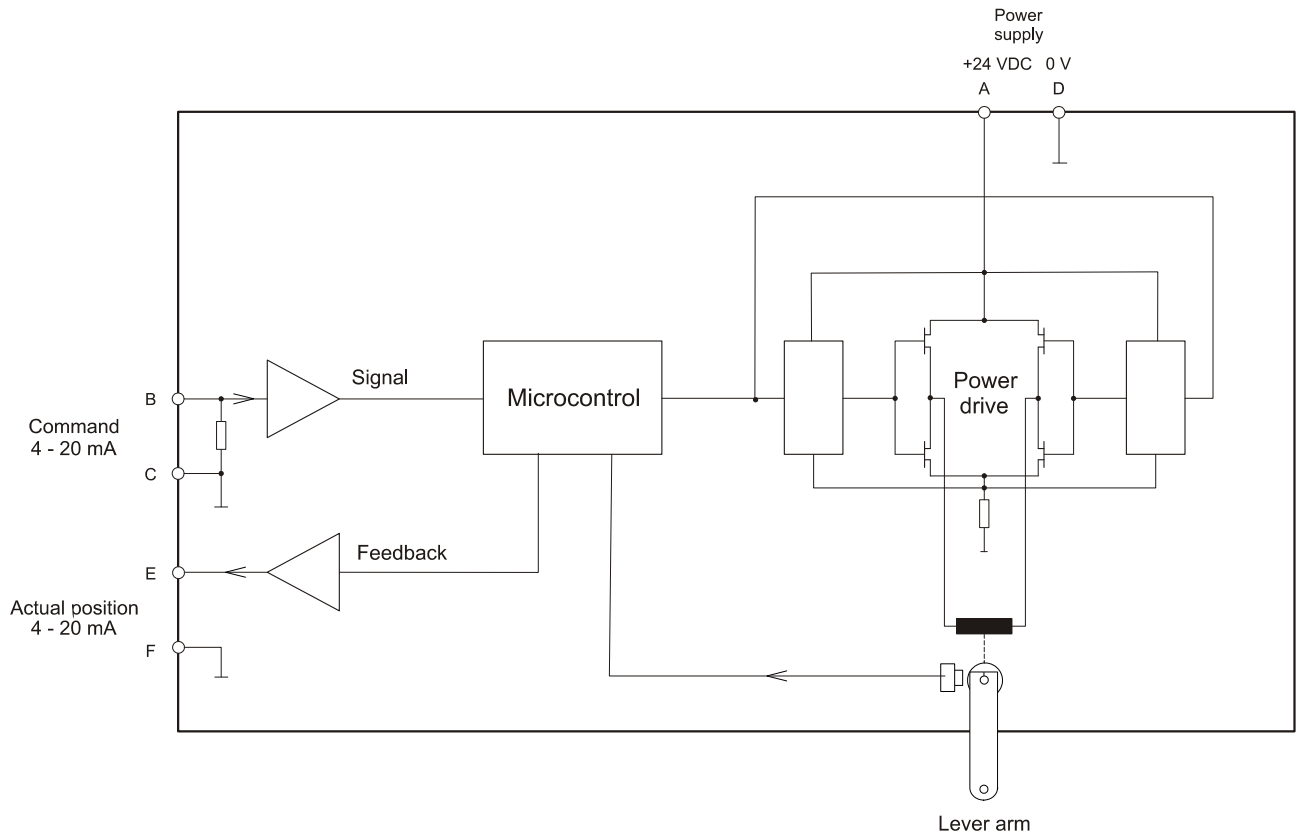

**Figure 2: Functional block diagram**

## 3 Specifications of Positioning System StG 40.90-09 PD

### 3.1 Design and Mode of Operation

Torque is generated by a DC disc armature motor and transmitted to the governor output shaft by way of a gearbox.

A feedback cam is mounted on the governor output shaft which is scanned contactlessly by a probe, thus providing the precise position of the output shaft as electrical signal.

If the actuator strikes against a stop, as may be caused by engine overload or cylinder failure, the current limitation will take effect after approx. 20 seconds; by this the current to the actuator is reduced to a value that cannot harm the motor.

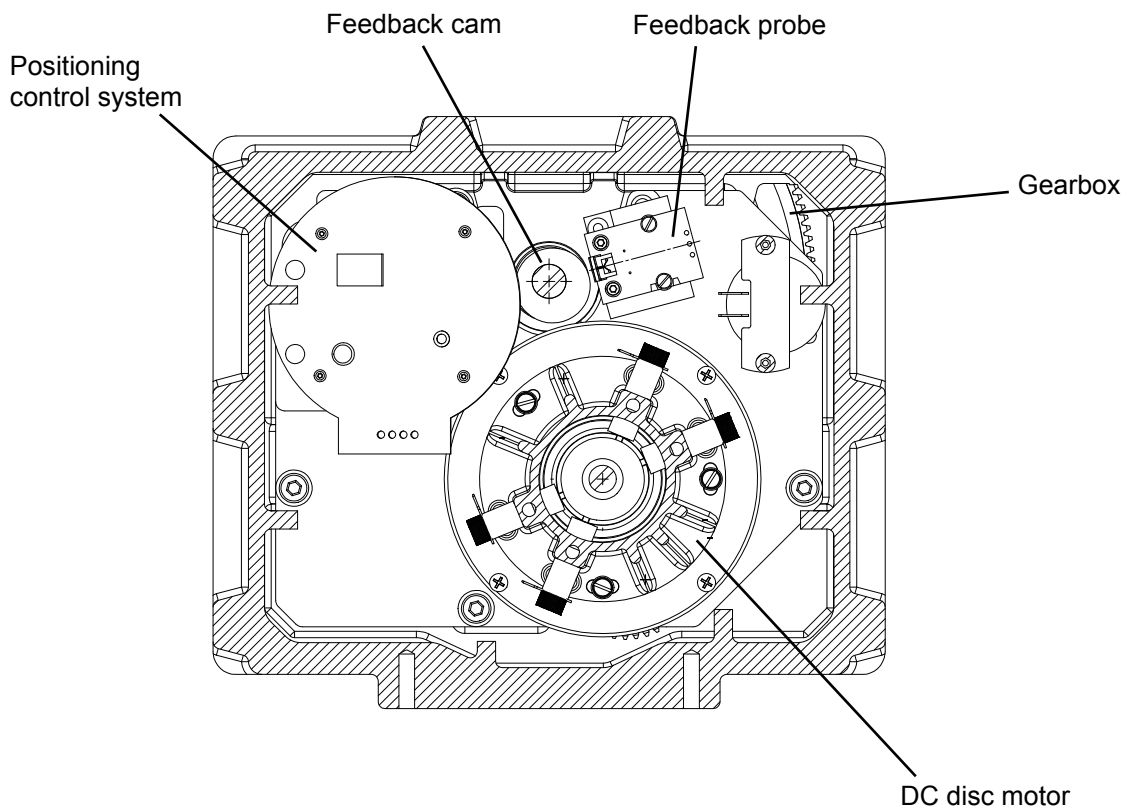

**Figure 3: Principle of StG 40.90-09 PD**

Altogether, this type of positioner offers following advantages:

- High regulating power working in either direction.
- Extremely low current consumption during steady state and relatively low current consumption on changes of load.
- Indifference to slow voltage changes of power supply; abrupt voltage changes, however, will cause governor disturbances.

### 3.2 Electrical Specification

nom. supply voltage	24 V DC
max. voltage	33 V DC
min. voltage	16 V DC
maximum ripple voltage at max. actuator current	10 % at 100 Hz
acceptable voltage drop at max. actuator current	max. 10 % at control unit
fuse protection	10 A (external, by user)
current consumption	approx. 300 mA, additionally current of actuator
steady state variation	±0.25 %.
storage temperature	-40°C to +105°C.
operating ambient temperature	-25°C to +90°C.
humidity	up to 98 %

#### Input “*command*”

proportional input

alternatively :

current signal	4 ... 20 mA	350 Ω input resistance
voltage signal	0 ... 5 V	100 kΩ input resistance
	0 ... 10 V	20 kΩ input resistance
PWM	50 ... 500 Hz	100 kΩ input resistance (pull up optional)

#### Output “*actual position*”

proportional output

alternatively

current signal	4 ... 20 mA	max. 220 Ω burden resistance
PWM	50 ... 500 Hz	lowside switch, 4,7 kΩ pullup $U_{rest} < 1 \text{ V at } I_{max}$ $I_{max} = 0.3 \text{ A}$

### 3.3 Actuator Specification

	<b>StG 40.90-09 PD</b>
Effective rotation at the output shaft	90°
Max. torque at the governor output shaft	approx. 40 Nm
Torque in steady state condition	approx. 15.7 Nm
Response time 0-100 % without load	< 280 ms
Current consumption	
maximum current	approx. 7 A
safe current in steady state condition	max. 2.3 A
Storage temperature	-40 ... +105°C
Ambiente temperature in operation	-20 ... +90°C
Humidity	up to 98 %
Protection grade	IP 65
Weight	approx. 25 kg

### 3.4 Dimensions

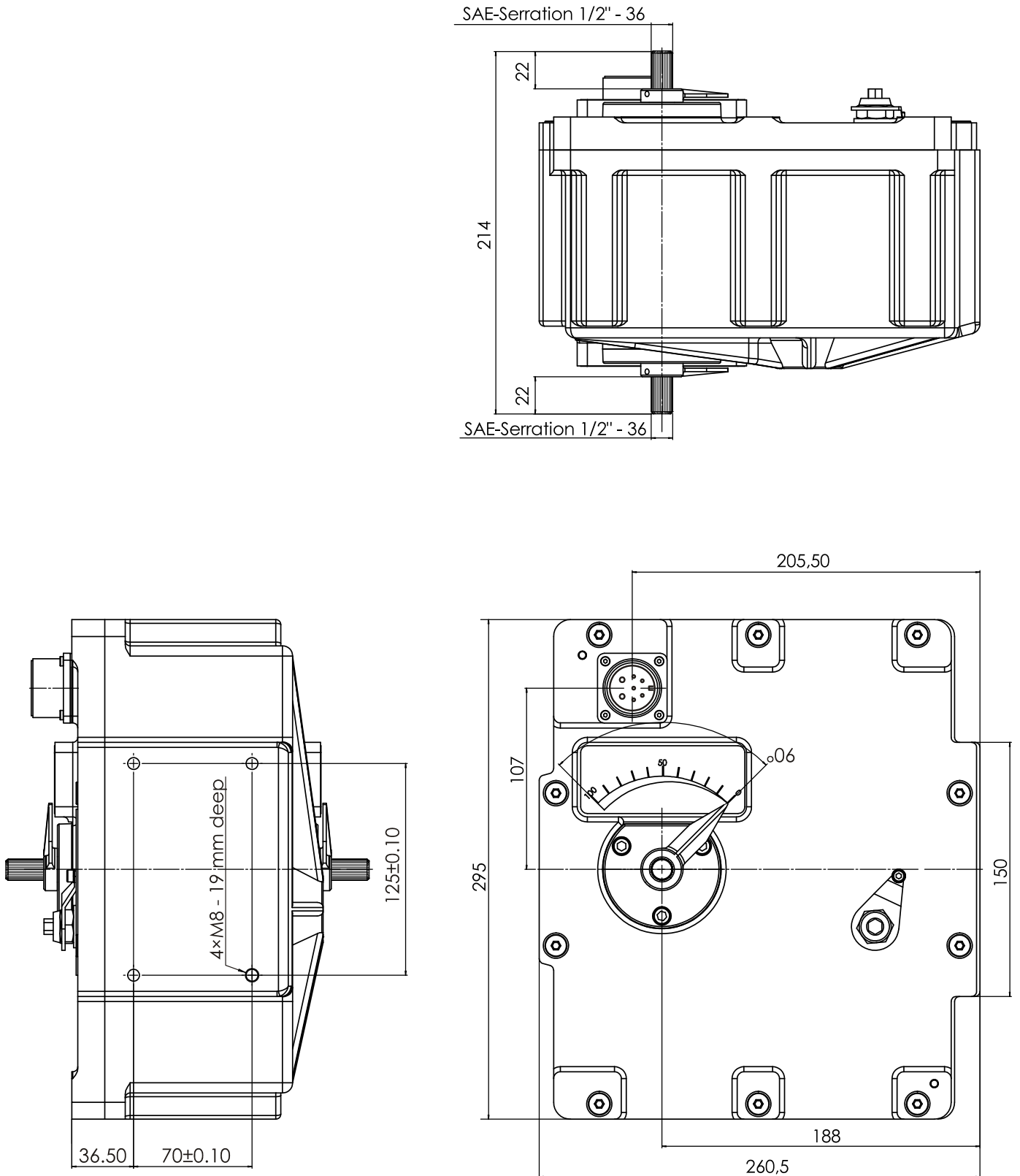

**Figure 4: Dimensional drawing StG 40.90-09 PD**

## 4 Installation and Regulating Linkage

### 4.1 Installation

The positioner must be firmly mounted on the engine using a support with stiffened brackets. Vibrating arrangements as may be caused by weak bracket material or missing stiffenings must be avoided by all means as this will increase vibrations and lead to faster wear of positioner and linkage.

### 4.2 Regulating Linkage

#### 4.2.1 Length of Lever Arm

The length “L” of the lever arm is determined in such a way that approx. 90 % of the governor output shaft adjustment angle can be used. Based on this, “L” for governors with

90° adjustment angle is calculated as:

$$L \sim 0.75 \cdot a$$

with "a" being the travel distance of the injection pump or the carburettor.

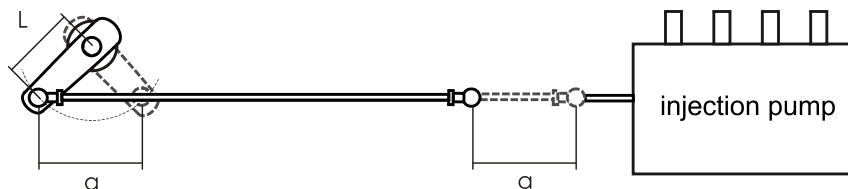

**Figure 5: Length of Lever Arm**

#### 4.2.2 Connecting Linkage

The connecting linkage from the governor to the injection pump or the carburettor should be length-adjustable and have a (pressure or tension) elastic link. If the actuators torque is less than 10 Nm, the elastic link is not needed. If possible, joint rod heads in accordance with DIN 648 should be used as connecting links. The linkage must operate easily and without clearance.

In case of friction or backlash in the linkage connecting actuator and injection pump resp. throttle valve no optimal control is possible.

### 4.2.3 Linkage Adjustment for Diesel Engines

The length of the connecting linkage is adjusted in such a way that with the governor in stop position the injection pump is set to 0 - 2 fuel marks. (Travel of the injection pump control rack is limited by the governor.)

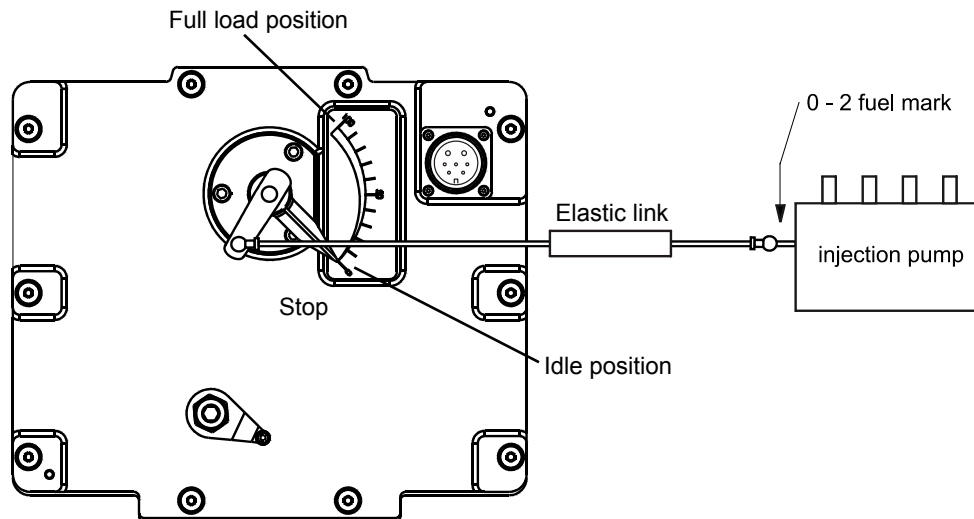

**Figure 6: Example of linkage for diesel engines**

The resistance of the pressure elastic link is overcome when the control rack has reached the full load stop and the speed continues to decrease (overload). Furthermore, the elastic link is overcome when stopping via the emergency switch.



#### 4.2.4 Linkage Adjustment for Carburettor Engines

For carburettor or gas engines, the length of the connecting linkage is adjusted in such a way that with the governor in full load position the throttle valve is completely open. In idling speed position, the elastic link must be slightly overcome. This allows adjustment of the idle screw without changing the governor adjustment.

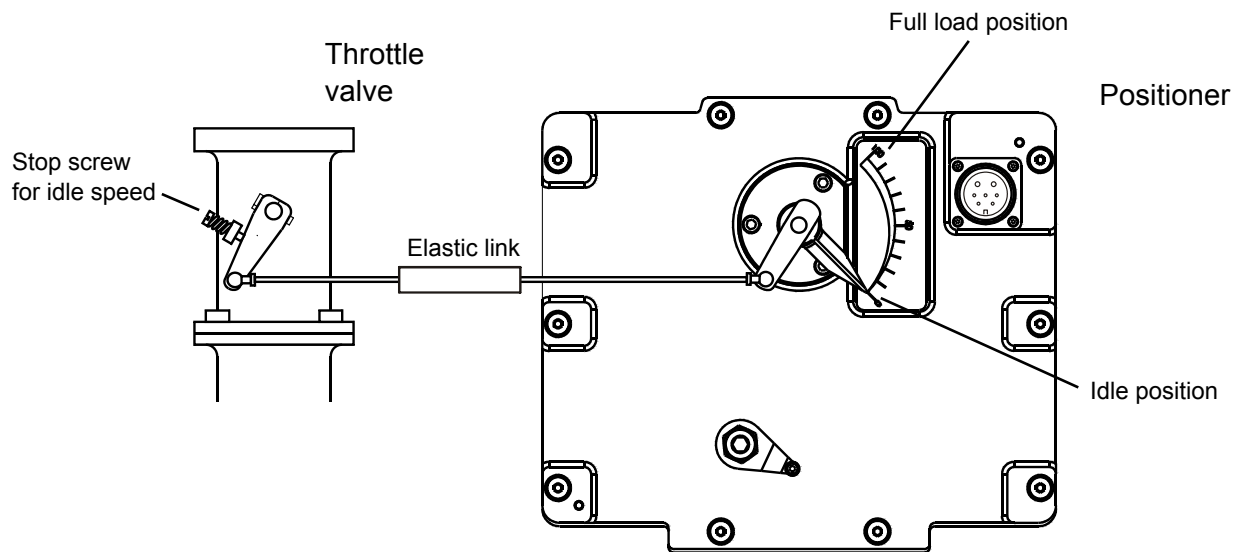

**Figure 7: Example of linkage for gas engines**

If carburettor or injection pump are to the left of the governor as opposed to their position on the drawings, then the direction of motion of the elastic link must also be reversed.

## 5 Electrical Connection

### 5.1 Pin Assignment

A	Power supply (+)	24 VDC
B	Setpoint (+)	4 ... 20 mA
C	Setpoint (-)	0 VDC
D	Power supply (-)	0 VDC
E	Position value (+)	4 ... 20 mA
F	Position value (-)	0 VDC
G	n.c.	

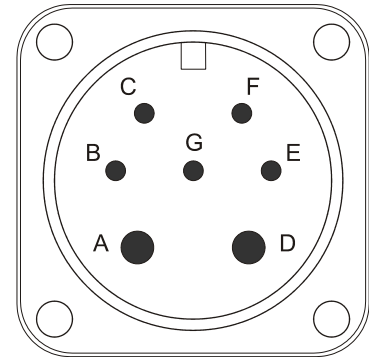

Figure 8: Pin assignment of StG 40.90-09 PD

### 5.2 Connection of Power Supply

Inappropriate choice of power supply or insufficient battery capacitance or incorrect connection of the power supply line or too small cable sizes of the feed line and the motor line of the positioner are bound have an adverse effect upon the performance of the speed governor. In steady state operation, this will cause a heavy increase of current consumption and unnecessary vibration of the positioner drive. The high current consumption will in its turn lead to overheating of the actuator or the position control unit, and the vibration will result in premature wear of the gear and bearing parts or of the linkage.

**NOTICE**

In altogether, the lifetime of the control system is distinctly reduced by the errors described above..

The following figure shows both a wrong and a correct cabling:

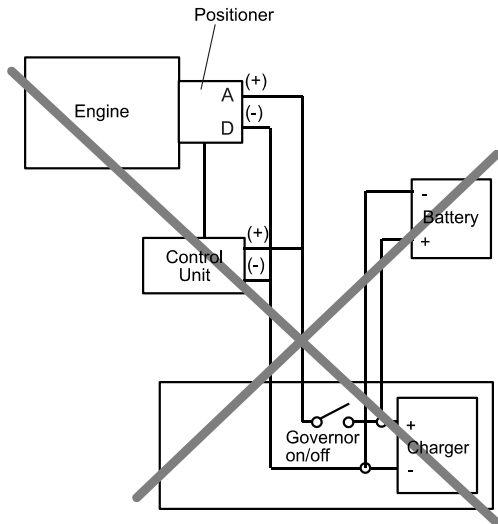

Ripple voltage of the charger is fed directly into the electronic governor!  
This will damage the actuator!

wrong

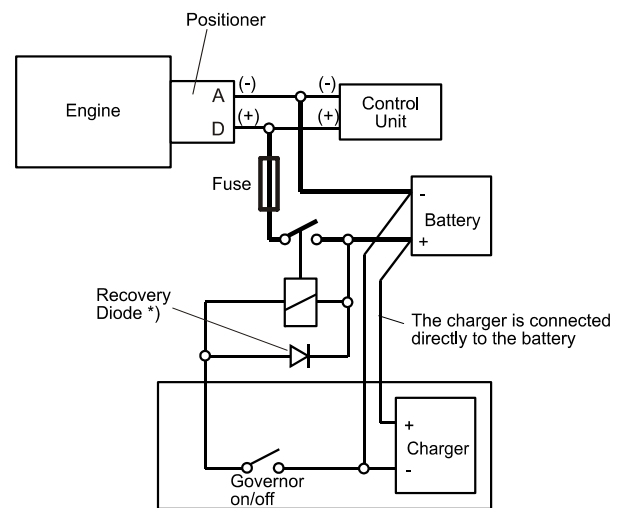

The control unit is connected directly to the battery, so chargers ripple voltage is buffered!

correct

\*) Coils (e.g. stopping solenoid, gas valve) must be equipped with a protective circuit to eliminate high inductance voltages. Diode type e.g. 1N4002

Figure 9: Correct Connection of Power Supply

**NOTICE**

If there are battery chargers with rapid charge mode installed in the plant, the rapid charge mode should not be used during operation.

If there is no battery provided, **it is absolutely necessary** that a three phase power supply or a **stabilized** single phase power supply with at least 24 V DC, 10 Amps output power **be used** as a power source.

**NOTICE**

The cable sizes and cable lengths described in the wiring diagrams must not be exceeded!

When power supply, battery and cabling have been correctly dimensioned, then on starting the engine or with the positioner operating at maximum current consumption (approx. 6.4 A), a drop of the supply voltage directly at the control unit of approx. 2 Volts maximum only will be admissible.

## 6 Figure List

Figure 1: Example for relation between current input signal and position .....	5
Figure 2: Functional block diagram .....	6
Figure 3: Principle of StG 40.90-09 PD .....	7
Figure 4: Dimensional drawing StG 40.90-09 PD .....	10
Figure 5: Length of Lever Arm .....	11
Figure 6: Example of linkage for diesel engines .....	12
Figure 7: Example of linkage for gas engines .....	13
Figure 8: Pin assignment of StG 40.90-09 PD .....	14
Figure 9: Correct Connection of Power Supply .....	15

## 7 Download of Manuals

Technical manuals can be downloaded in pdf-format from our homepage:

[www.heinzmann.com](http://www.heinzmann.com)

If the desired manual should not be available there, send an e-mail to:

[info@heinzmann.de](mailto:info@heinzmann.de)

or write to:

### **HEINZMANN GmbH & Co. KG**

Technische Redaktion

Am Haselbach 1

D-79677 Schönau/Germany

#### **Please include the following information:**

- your name
- name and address of your company
- e-mail or address where you want the manuals to be sent to (if different from above)
- item code (as on front page, bottom right) and title of the desired manual  
or alternatively the technical data of your HEINZMANN equipment

We would be pleased to receive your comments about the contents and presentation of our publications. Send your comments to the e-mail or address shown above please.

*Declaration of Incorporation of partly completed machinery*  
according to Machinery Directive 2006/42/EC

Manufacturer: **HEINZMANN GmbH & Co. KG**  
**Am Haselbach 1**  
**79677 Schönau**  
**Tel.: +49 7673-8208-0**

hereby declares that the following product:

Make: Positioner with DC disc motor and gear  
Type: StG 40.90.09-PD  
Serial number: from .....

Project number: StG EC 40.90-09-PD  
Year of manufacture: 2010

meets following essential requirements of Machinery Directive 2006/42/EC:

Annex I, 1-st item: 1.1.2. d); 1.1.4.; 1.1.5.; 1.1.6.; 1.1.7.; 1.1.8.; 1.2.1.; 1.2.3.; 1.3.1.;  
1.3.2.; 1.3.7.; 1.3.9.; 1.5.1.; 1.5.16.; 1.5.2.; 1.5.5.; 1.5.6.; 1.5.7.; 1.6.3.; 3.2.1.; 3.2.2.; 3.3.3.;  
3.3.4.; 3.3.5.; 4.1.2.1.; 4.1.2.2.; 4.1.2.3.; 4.1.2.4.; 4.1.2.5.; 4.1.2.6. a); 4.1.2.6. c);  
4.1.2.6. e); 4.2.1.; 4.2.1.4.; 4.3.1.; 4.3.2.; 4.3.3.; 4.4.1.; 4.4.2.; 5.1.; 5.2.; 6.1.1.; 6.4.3

In addition the following standards have been used:

- Low Voltage Directive 2006/95/EC:2007-03-16
- Directive ATEX 94/9/EC:1994-03-23
- EMC Directive 2004/108/EG:2004-12-15

The partly completed machinery must not be put into service until the relevant machinery into which it is to be incorporated has been declared in conformity with the essential requirements of the Machinery Directive 2006/42 /EC.

Upon justified request the manufacturer will be obligated to provide the specific documents regarding the product listed above to authorities.

The technical documentation for the machinery is available from:

Engineering management, HEINZMANN GmbH & Co. KG, Am Haselbach 1, 79677 Schönau

.....  
Markus Gromer  
Chief Executive Director

Schönau, 01.06.2010