



**Heinzmann GmbH & Co. KG**  
**Engine & Turbine Controls**

Am Haselbach 1  
D-79677 Schönau (Schwarzwald)  
Germany

Phone +49 7673 8208-0  
Fax +49 7673 8208-188  
E-mail [info@heinzmann.com](mailto:info@heinzmann.com)  
[www.heinzmann.com](http://www.heinzmann.com)

V.A.T. No.: DE145551926

**HEINZMANN®**

Digital Electronic Speed Governors

**Digital Control System**  
**PEGASOS**

**for diesel-electric locomotives**

**Iranian Railways - GT26CW**







## Table of content



	<b>Page</b>
<b>1 Security advises and symbols .....</b>	<b>5</b>
<b>2 Introduction .....</b>	<b>7</b>
<b>3 System description .....</b>	<b>8</b>
<b>4 Block diagrams.....</b>	<b>10</b>
<b>5 System setup.....</b>	<b>13</b>
<b>6 Special locomotive software parameters for Iranian Railways .....</b>	<b>18</b>
<b>7 Power adjustment.....</b>	<b>25</b>
<b>8 System components .....</b>	<b>29</b>
8.1 Sensors.....	29
8.1.1 Speed pickup IA 22-76 .....	29
8.1.2 Cooling media temperature sensor TS 01-28-PT1000 .....	30
8.1.3 Oil pressure sensor.....	31
8.1.4 Boost pressure sensor .....	31
8.2 Control unit PEGASOS DC 40.2 - 01 .....	33
8.2.1 Technical data.....	33
8.2.2 Dimensions .....	34
8.2.3 Locomotive interface .....	35
8.3 StG 40 actuator .....	35
8.3.1 Design and mode of operation .....	35
8.3.2 Installation .....	36
8.3.3 Technical data - StG 40 actuator .....	37
8.3.4 StG 40 dimensions .....	38
<b>9 Electric connection .....</b>	<b>39</b>
9.1 General instructions.....	39
9.2 Connecting diagram of PEGASOS control system .....	40
9.3 Cable dimensions.....	41
9.4 Cable harness.....	42
9.5 Connector types and numbers .....	43
<b>10 Periodical governor inspection and maintenance .....</b>	<b>44</b>
10.1 PEGASOS maintenance .....	44
10.2 Injector linkage adjustment .....	45

---

	<b>Page</b>
<b>11 Troubleshooting.....</b>	<b>49</b>
11.1 Control box indicators .....	49
11.2 Error Memory .....	50
11.3 Detailed troubleshooting tips.....	51

## 1 Security advises and symbols

 <b>Warning</b>	<p>Read this entire manual and all other publications appertaining to the work to be performed before installing, operating or servicing your equipment. Practice all plant and safety instructions and precautions.</p>
 <b>Danger</b>	<p>Failure to follow instructions may result in personal injury and/or damage to property.</p>
 <b>Danger! High Voltage</b>   <b>Danger</b>	<p><b>Please note before commissioning the installation:</b></p> <p>Before starting to install any equipment, the installation must have been switched dead!</p> <p>Be sure to use cable shieldings and power supply connections meeting the requirements of the <i>European Directive concerning EMI</i>.</p> <p>Check the functionability of the existing protection and monitoring systems.</p>
 <b>Danger</b>	<p><b>To prevent damages to the equipment and personal injuries, it is imperative that the following monitoring and protection systems have been installed:</b></p> <ul style="list-style-type: none"> <li>Overspeed protection acting independently of the speed governor</li> <li>Overtemperature protection</li> </ul> <p><b>Generator installation will in addition require:</b></p> <ul style="list-style-type: none"> <li>Overcurrent protection</li> <li>Protection against faulty synchronization due to excessive frequency, voltage or phase differences</li> <li>Reverse power protection</li> </ul>
	<p><b>Overspeeding can be caused by:</b></p> <ul style="list-style-type: none"> <li>Failure of the voltage supply</li> <li>Failure of the control unit or of any accessory device</li> <li>Failure of the actuator</li> <li>Sluggish and blocking linkage</li> </ul>

 <b>Warning</b>	<p><b>Electronically controlled injection (MVC) will in addition require to observe the following:</b></p> <p>With <b>Common Rail</b> systems a separate mechanical flow limiter must be provided for each injector pipe.</p> <p>With <b>Pump-Pipe-Nozzle (PPN)</b> and <b>Pump Nozzle (PNE)</b> systems fuel release may be enabled only by the movement of control piston of the solenoid valve. This is to inhibit fuel from being delivered to the injection nozzle in case of seizure of the control piston.</p>
 <b>Warning</b>	<p>The examples, data and any other information in this manual are intended exclusively as instruction aids and should not be used in any particular application without independent testing and verification by the person making the application.</p>
 <b>Danger</b>	<p>Independent testing and verification are especially important in any application in which malfunction might result in personal injury or damage to property.</p>
	<p><b>HEINZMANN</b> make no warranties, express or implied, that the examples, data, or other information in this volume are free of error, that they are consistent with industry standards, or that they will meet the requirements for any particular application.</p>
	<p><b>HEINZMANN</b> expressly disclaim the implied warranties of merchantability and of fitness for any particular purpose, even if <b>HEINZMANN</b> have been advised of a particular purpose and even if a particular purpose is indicated in the manual.</p>
	<p><b>HEINZMANN</b> also disclaim all liability for direct, indirect, incidental or consequential damages that result from any use of the examples, data, or other information contained in this manual.</p>

## **2 Introduction**

This manual includes detailed setup and maintenance informations about the HEINZMANN **PEGASOS locomotive control system DC 40.2-01** for Iranian Railways locomotives, GT 26CW type.

It is based on the following HEINZMANN manuals:

**Digital Control System Pegasos for Locomotives, DG 96 001-e**

**Basic Information 2000 for Digital Governors, DG 00 001-e**

**Operating Instructions - Communication program DcDesk 2000, DG 00 003-e**

### 3 System description

The Heinzmann PEGASOS locomotive control system for Iranian Railways consists of the following components:

1. PEGASOS controller DG 40.2-01
2. Actuator StG 40-10
3. Inductive speed pickup IA 22-76 (2 pcs.)
4. Lube oil pressure sensor DSO 01-10
5. Charge air pressure sensor DSG 04-2
6. Coolant pressure sensor TS 01-28-PT1000
7. Crankcase pressure switch
8. Lube oil temperature sensor TS 01-28-PT1000
9. Coolant temperature sensor TS 01-28-PT1000
10. Engine terminal box
11. Cable harness with CANNON connectors

The Heinzmann PEGASOS *controller* DG 40.2-01 for GT26CW locomotive is installed in the cooling system section under the AC cooling fans, next to the air compression section. It is built in an extra panel box.

The *actuator* StG 40-10 replaces the original hydraulic Woodward PG-R governor. It has a maximum output torque of 44 Nm and rotary output shaft travel of 42°. It is an electric actuator with electromagnetic position feedback.

Two active magnetic engine *speed pickups* IA 22-76 (M24x1,5 thread) are placed at the flywheel. Pickup no.1 is active, pickup no.2 standby for “hot” redundancy (replacing no.1 in case of sensor failure without stopping the engine).

The *lube oil pressure sensor* DSO 01-10 has a pressure range of 0 ... 10 bar and an output signal of 4 ... 20 mA. Supply voltage is 24 VDC from the Pegasos controller.

The *charge air pressure sensor* DSG 04-2 has a pressure range of 0 ... 2 bar and an output signal of 4 ... 20 mA. Supply voltage is 24 VDC from the Pegasos controller.

The *coolant pressure sensor* DSO 01-6 has a pressure range of 0 ... 6 bar and an output signal of 4 ... 20 mA. Supply voltage is 24 VDC from the Pegasos controller.

The *crankcase pressure switch* is adjusted to 3.75 mbar = 1,5 inch water column.

The *lube oil temperature sensor* TS 01-28-PT1000 has a measuring range of -40 ... +120 °C. It is a two-wire resistive PT1000 type.

The *coolant temperature sensor* TS 01-28-PT1000 has a measuring range of  $-40 \dots +120$  °C. It is a two-wire resistive PT1000 type.

The *engine terminal box* is located near the lube oil strainer. All sensor cables and the actuator cable are interconnected there.

Additional hardware items like sensors, I/O module or display module may be incorporated in the system on request.

### 4 Block diagrams

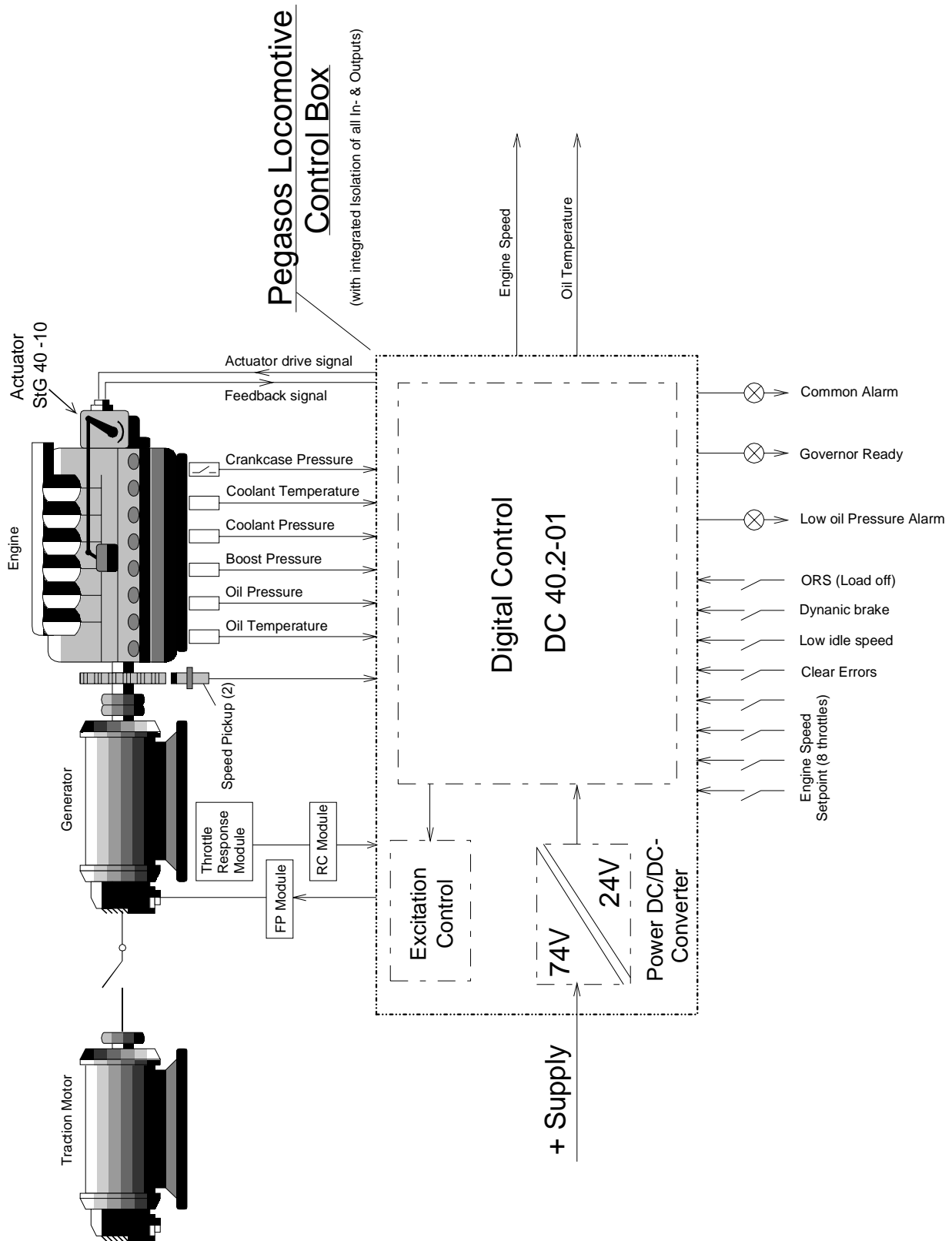

Fig. 1: Block diagram

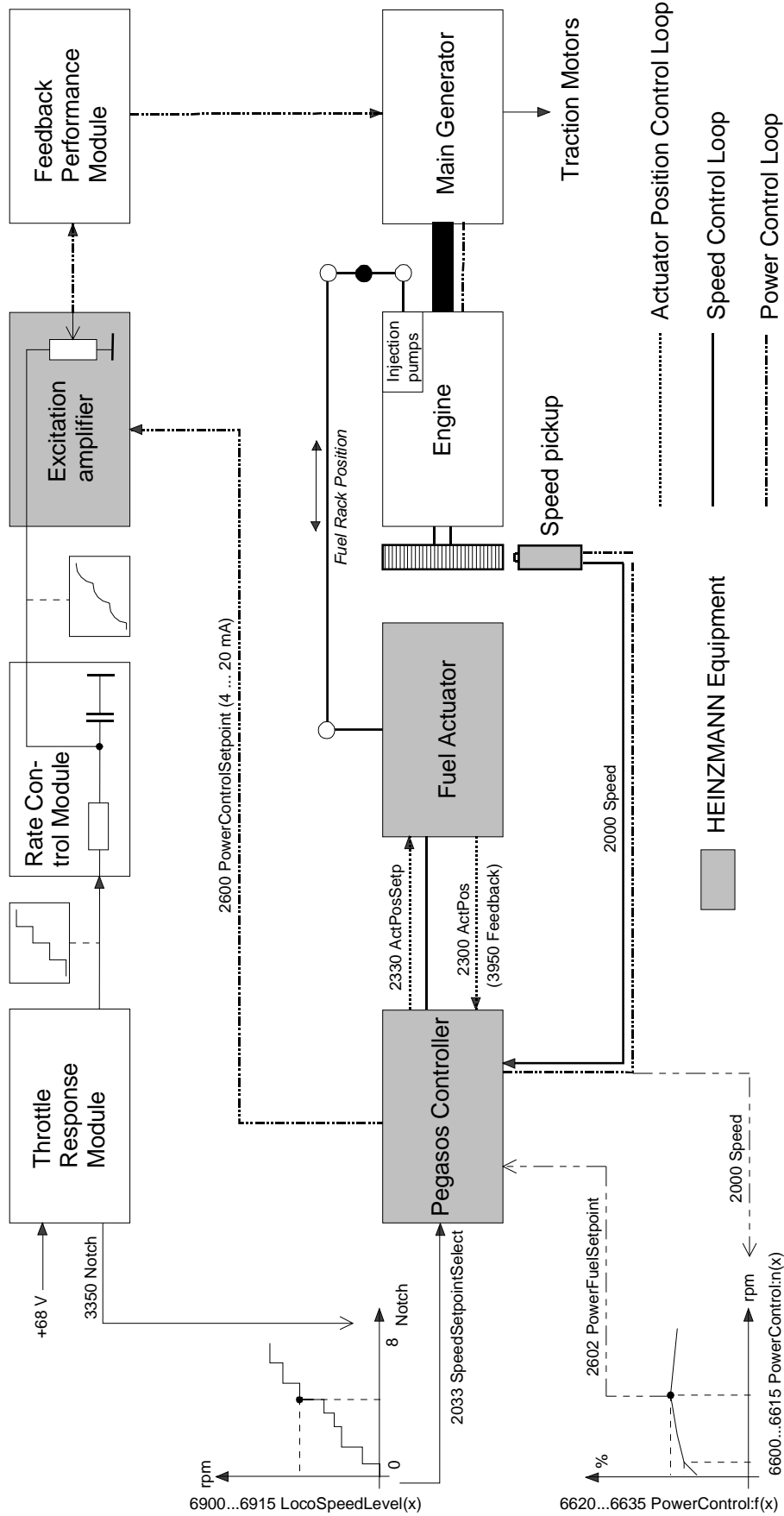

Fig. 2: Functional block diagram

Block diagram (Fig. 1) demonstrates the arrangement of the HEINZMANN controller in the locomotive traction system. All sensors, in- and outputs are shown.

Functional block diagram (Fig. 2) reflects the signal flow of the 3 HEINZMANN control circuits: speed control loop, servo (actuator position) loop and power control loop.

The *speed control loop* gets a speed setpoint given by the locomotive driver (trottle signal). This is converted into a number between 0 and 8 (parameter 3350 *Notch*) in the governor. A preset governor curve supplies the relation to speed setpoint (2033 *SpeedSetpointSelect*). The speed setpoint is compared with actual engine speed (speed pickup signal) and sent to a PID governor section. It's result is an actuator position setpoint in % (2330 *ActPosSetp*), used to control the fuel rack position. At a given load, a change in fuel injection will make a change in engine speed. Assuming correct governor PID settings, the actual engine speed will match the speed setpoint after a short period of time.

The *actuator position loop* is responsible for the actuator to match the position setpoint (2330 *ActPosSetp*). A drive current is sent to the actuator's disc motor, effecting a change in output shaft position. A feedback DC voltage signal (3950 *Feedback*) is returned to the governor and converted into an actual actuator position value in % (2300 *ActPos*). Assuming the actuator can supply the required torque, actual position will be equalized to the setpoint. This loop is serving the speed control loop, therefore it is also called servo loop.

The *power control loop* modifies the main generator's power output by varying the excitation signal. Goal is to keep the engine at the optimum load level, referring to actual engine speed. Depending on speed (2000 *Speed*), a preset curve in the governor supplies another actuator position setpoint (2602 *PowerFuelSetpoint*). Unlike the speed loop's actuator position setpoint (2300 *ActPosSetp*), this setpoint will not be matched by the actuator, directly. The tool to get the actuator position to the desired level is an excitation PID governor, comparing 2602 and 2300 measuring values. The governor output signal 2600 *PowerControlSetpoint*, physically a 4-20 mA current, is supplied to an excitation control amplifier. This unit, acting like an electronic potentiometer (replacing the Woodward governor rheostat), delivers a variable portion of voltage from the Throttle Response (TH) Module (retarded by Rate Control or RC Module) to the Feedback Performance (FP) Module. As a result the load is changed, effecting an actual engine speed change. This will then be compensated by the speed control loop, modifying the actuator position setpoint (2330 *ActPosSetp*). Summarizing, actual engine speed is the link between speed control loop and power control loop.

## 5 System setup

The system setup procedure requires a PC with *DcDesk 2000* HEINZMANN communication software, allowing access to 47.x.xx software versions in level 6. Refer to HEINZMANN manual “Operating Instructions - Communication Program DcDesk 2000”, DG 00 003-e.

### 1) Adjust speed pickups

The speed pickup IA 22-76 (M24x1,5) has an operating distance of 2 ... 3 mm. (Turn pickup cw until it touches the flywheel teeth. Turn back ccw 1,5 ... 2 rotations and lock.)

The standard speed pickup IA 02-76 (M 16x1,5) has an operating distance of 0,5 ... 0,8 mm. (Turn pickup cw until it touches the flywheel teeth. Turn back ccw 1/2 rotation and lock.)

### 2) Actuator installation

Use the two supplied HEINZMANN plates to install the actuator. Set the output shaft in the same position, as the PG-R governor was before. Pay attention to the required sense of rotation (0% = stop, 100 % = full fuel). Do not connect the fuel linkage, yet.

### 3) Wiring

All cable connections must be carried out according to the HEINZMANN wiring diagram.

The following connections between governor and locomotive are to be made:

Signal	Description	Locomotive system	Pegasos control box, connector 1 (14 pin)
Power supply	+64/74 VDC governor supply voltage	power supply line	pin E
Power negative	0 VDC	power supply line	pin F
AV	solenoid A	engine governor control, TH	pin D
BV	solenoid B		pin A
CV	solenoid C		pin B
DV	solenoid D		pin C
ORS	overriding solenoid		pin J
CE	clear governor errors		pin K
LI	low idle speed switch		pin L
Dynamic brake	brake power setting	gen. field control, 6T	pin M
Throttle response module voltage	load reference voltage from TH module (via RC module)	load regulator, EA	pin P

Load regulator voltage	load regulator output voltage (to FP module)	load regulator, EB	pin H
Negative	0 V reference for load regulator	load regulator, NM	pin N

#### 4) Power supply

Make sure the actuator is not connected to the control box. Switch on the 64 VDC locomotive power supply. Check the indicator lamps at the PEGASOS control box. The red alarm lamp must come on. Switch off the power supply again.

#### 5) Automatic actuator adjustment

The actuator feedback voltage references must be set/checked before mounting the fuel linkage. Connect the actuator cable, first. Switch on locomotive 74 VDC power supply.

Connect a PC with *DcDesk 2000* software to the Pegasos controller, using a HEINZMANN communication cable. (Do not use standard serial cable type! This may damage the PC's COM port.

Start *DcDesk 2000*, go online and perform *Automatic actuator adjustment* (Menu: *Governor*).

The actuator will move to 100 % position and back to 0 %.

Check/set the value of parameter 1952 *FeedbackErrLow* = 100 digits (value for low feedback error limit).

Read the digit value in parameter 1951 *FeedbackRefHigh* (i.e. 58000) and add 4000 digits.

Enter the result (i.e. 62000 digits) in parameter 1953 *FeedbackErrHigh*.

Save data in governor (F6).

#### 6) Test of actuator calibration and position loop

Set parameter 1700 *PositionerSetpoint* = 50 % (default value).

Activate positioning mode by setting parameter 5700 *PositionerOn* = 1.

Check measuring value 2300 *ActPos*. It must be 50 %.

Check position indicator at actuator output shaft. It must show 50 % as well.

Set parameter 1700 *PositionerSetpoint* = 0 %.

The measuring value 2300 *ActPos* will drop to 3 % (310 *ActPosSecureMin* = 3 %).

Switch off the positioning mode by setting parameter 5700 *PositionerOn* = 0.



**Note**

If the indicator did not point at 50 % position, repeat the automatic actuator adjustment and watch the procedure. The actuator must reach min. and max. position during adjustment. Repeat calibration and position loop test.

### 7) Adjust the fuel linkage

Put on the control lever with the adjustable bushing, but do not fasten it, yet.

Connect the injector control rod to the actuator control lever. Use washers between these parts. Ensure a free motion of the linkage between zero and full fuel position.

Pull both, injector control rod and actuator lever, to zero fuel and fix the actuator output shaft to the lever. Make sure, the linkage can be moved across the full range without friction.

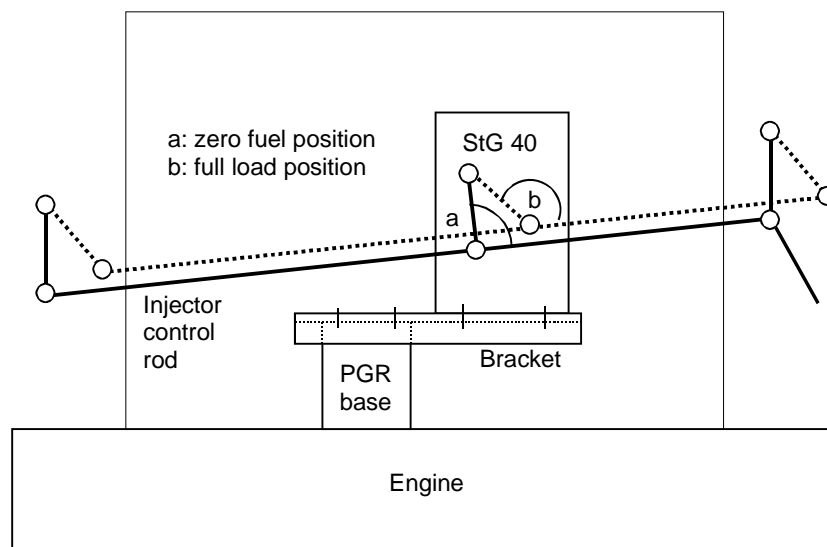

Fig. 2: Actuator installation

### 8) Check digital inputs

Establish connection between PC and governor. On *DcDesk 2000, Graphic, Overview*, the *Switch Functions* status must change between 0 and 1, when the input is switched.

Caution: Some switches may not work, unless the engine is running.

2815 SwitchSpeedFix1	=	0/1	closed = 1, "Low idle"	connector 1 pin L
2818 SwitchSlide	=	0/1	closed = 1, "ORS"	connector 1 pin J
2819 SwitchNotch3	=	0/1	open = 1, "Solenoid B"	connector 1 pin A
2820 SwitchNotch2	=	0/1	open = 1, "Solenoid C"	connector 1 pin B
2821 SwitchNotch1	=	0/1	closed = 1, "Solenoid D"	connector 1 pin C
2822 SwitchNotch0	=	0/1	open = 1, "Solenoid A"	connector 1 pin D
2823 SwitchPowerLimit	=	0/1	open = 1, "Dynamic brake"	connector 1 pin M
2828 SwitchErrorReset	=	0/1	closed = 1, "Clear errors"	connector 1 pin K

Truth table for *speed setting* throttles:

Throttle	Speed setpoint (parameter 2033)	Solenoid A (bit 0)	Solenoid B (bit 3)	Solenoid C (bit 2)	Solenoid D (bit 1)*	Software parameter
stop					X	6900
low idle	250 ... 280 rpm	switch overrides solenoids A,B and C				17
0, 1	320 rpm					6902
2	405 rpm	X				6903
3	497 rpm			X		6906
4	567 rpm	X		X		6907
5	655 rpm		X	X	X	6912
6	730 rpm	X	X	X	X	6913
7	829 rpm		X	X		6914
8	904 rpm	X	X	X		6915

\*) Solenoid D status is inverted in the governor: 2821 SwitchNotch1 = 0 means D = active!

6900 *LocoSpeedLevel(0)* is set to 150 rpm and is used to stop the engine by speed depending fuel limit to 0 % (below 220 rpm).

Speed changes between throttles will follow the speed ramp settings in parameters 230 ...235.

There are 3 sectional ramps: from 0 rpm to parameter value 236 *SpeedSwitchToRamp2*, between 236 and 237 *SpeedSwitchToRamp3* and above 237 value.

All locomotive speed levels, which are **not** used in normal operation, are set to 320 rpm:

6901, 6904, 6905, 6908, 6909. (If any contact fails, the engine will not stop.)

During dynamic brake, solenoid B is activated. Curve speed values 6910 and 6911 will be used for dynamic brake operation, only.

### 9) Check analogue inputs

On *DcDesk*, *Graphic*, *overview*, check the following *Sensor Values* (with engine stopped):

2904 <i>BoostPressure</i>	=	0,00 bar	charge air pressure
2905 <i>OilPressure</i>	=	0,00 bar	lube oil pressure
290.. <i>CoolantPress</i>	=	0,00 bar	coolant pressure
2907 <i>CoolantTemp</i>	=	... °C	coolant temperature
2909 <i>OilTemp</i>	=	... °C	lube oil temperature

In any case of sensor failure and respective error messages, refer to chapter 11 Troubleshooting. *Crankcase pressure*: The displayed value does not directly correspond with the actual pressure. The monitoring is carried out using a precision overpressure switch device.

### 10) Speed governor function check

Establish connection between PC and governor. Open *DcDesk 2000, Graphic, Curve vs. time*.

Enter the following measuring values in the table for the graphic display:

2000 <i>Speed</i>	=	0 ... 1200	1/min
2033 <i>SpeedSetpSelect</i>	=	0 ... 1200	1/min
2300 <i>ActPos</i>	=	0 ... 100	%
2701 <i>FuelLimitMax</i>	=	0 ... 100	%
2904 <i>BoostPressure</i>	=	0 ... 2	bar
2905 <i>OilPressure</i>	=	0 ... 10	bar.
2907 <i>CoolantTemp</i>	=	0 ... 120	°C
2909 <i>OilTemp</i>	=	0 ... 120	°C

Start the engine.

If it does not start, watch the actuator during engine cranking. It must open up to start fuel: 260 *StartFuel 1* = 50,0 %.

If the actuator opens, but engine does not start, check the fuel supply.

If necessary, increase the setting of parameter 260 *StartFuel 1*, temporarily.

About 30 s after start, check the PC display for the following values:

1. Values 2000 *Speed* and 2033 *SpeedSetpointSelect* must be equalized (idle speed).
2. Value 2300 *ActPos* must be lower than 2701 *FuelLimitMax* and below 20 %.
3. Speed 2000 and actuator position 2300 must be stable.

After a few minutes of warming up, test the engine in low idle (use separate “low idle” switch), if available. Then go back to normal idle speed (throttle 0).



Low idle speed is set in parameter 17 *SpeedFix1*. It is activated by a separate switch input at pin L1. This switch must be turned off for speed increase.

**Note**

Increase the speed setting stepwise from throttle 0 to throttle 8 and check the values in each throttle.

In case of speed instability (and absence of other problems, caused by speed pickup, fuel linkage, fuel or air supply), the speed governor PID settings may be modified (parameters 100, 101 and 102). Fast hunting will be cured by reducing 100 *Gain*, slow hunting by increasing 100 *Gain* or reducing 101 *Stability*. If these value modifications bring no improvement, the speed governor may not be responsible for the speed instability.

Unstable engine speed in just one or two throttle positions may be overcome by reducing the respective values of the PID map in *DcDesk 2000, Graphic, Map*.

## 6 Special locomotive software parameters for Iranian Railways

The standard parameters are described in Heinzmann manual “Basic information for digital governors, Level 6”, DG 00 001-e. There is a number of additional parameters in the Iranian Railways software 47.X.XX, which are described in this chapter.

### 1) Extended engine shutdown delay time for low oil pressure in idle (throttle 0)

In speed throttle 0, the low oil pressure shutdown is delayed according to parameter

$$503 \text{ OilPressEcyDelayIdle} = 60 \text{ sec.}$$

No-load condition is assumed, when actual actuator position (2300 *ActPos*) is between

$$504 \text{ OilPressIdleFuelMin} = 0 \%$$

and

$$505 \text{ OilPressIdleFuelMax} = 20 \%$$

The value in parameter 505 must be set between low idle and throttle 1 actuator position:

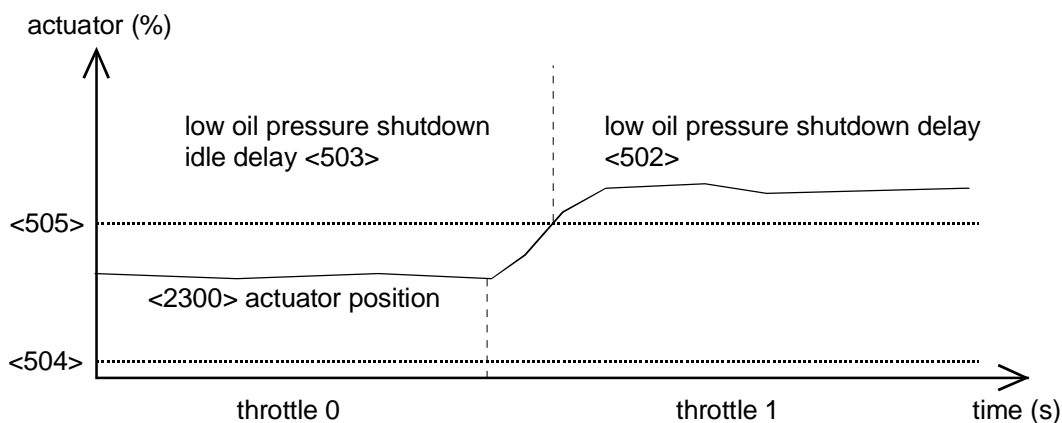

Fig. 3: Low oil pressure shutdown delay

This extended low oil pressure shutdown delay is activated by setting the function:

$$4503 \text{ OilPrEcyIdleDelayOn} = 1$$

Actuator position higher than preset in 505 will be regarded as non-idle condition and activate the standard low oil pressure shutdown delay time in parameter

$$502 \text{ OilPressEcyDelay} = 3 \text{ sec.}$$

### 2) Restart after Low Oil Pressure Engine Shutdown

There is a function to decide, whether a restart requires a manual governor reset or not:

$$4502 \text{ OilPrEcyStartResetOn} = 0/1$$

4502 = 0 : A manual reset using *DcDesk 2000* or “Clear Error” pushbutton is required.

4502 = 1 : Engine restart is possible without manual governor reset.

### 3) Power control / Power governor functions

All parameters concerning diesel-electric power are located in the 600 ... 699 number range.

All power measuring values are located in the 2600 ... 2699 number range.

All power functions are located in the 4600 ... 4699 number range.

There are two basic ways of controlling the power of diesel-electric locomotives via an excitation signal:

1. *Power control*, using a *speed depending excitation setpoint curve* (6600 ... 6615; 6640 ... 6655). All parameters, which are used for this control function, are named “*PowerControl ...*”

2. *Power governor*, using a *speed depending fuel setpoint curve* (6600 ... 6615; 6620 ... 6635). All parameters, which are used for this governor function, are named “*PowerGov ...*”. This power governor is used for Iranian Railway.

In the following, only **power governor and common parameters** are described:

The two main operating values for the power governor are:

2600 *PowerControlSetpoint* = y % (Percentage of load regulator output)

This replaces the Woodward PG-R load regulator signal to the FP module. It is the *output signal of the power governor*.

0 % means: no excitation signal to FP module.

100 % means: full voltage from RC module passed through to FP module

2602 *PowerGovFuelSetpoint* = x % (Actuator position setpoint for the load control)

This is the value from the excitation fuel setpoint curve, according to actual engine speed.

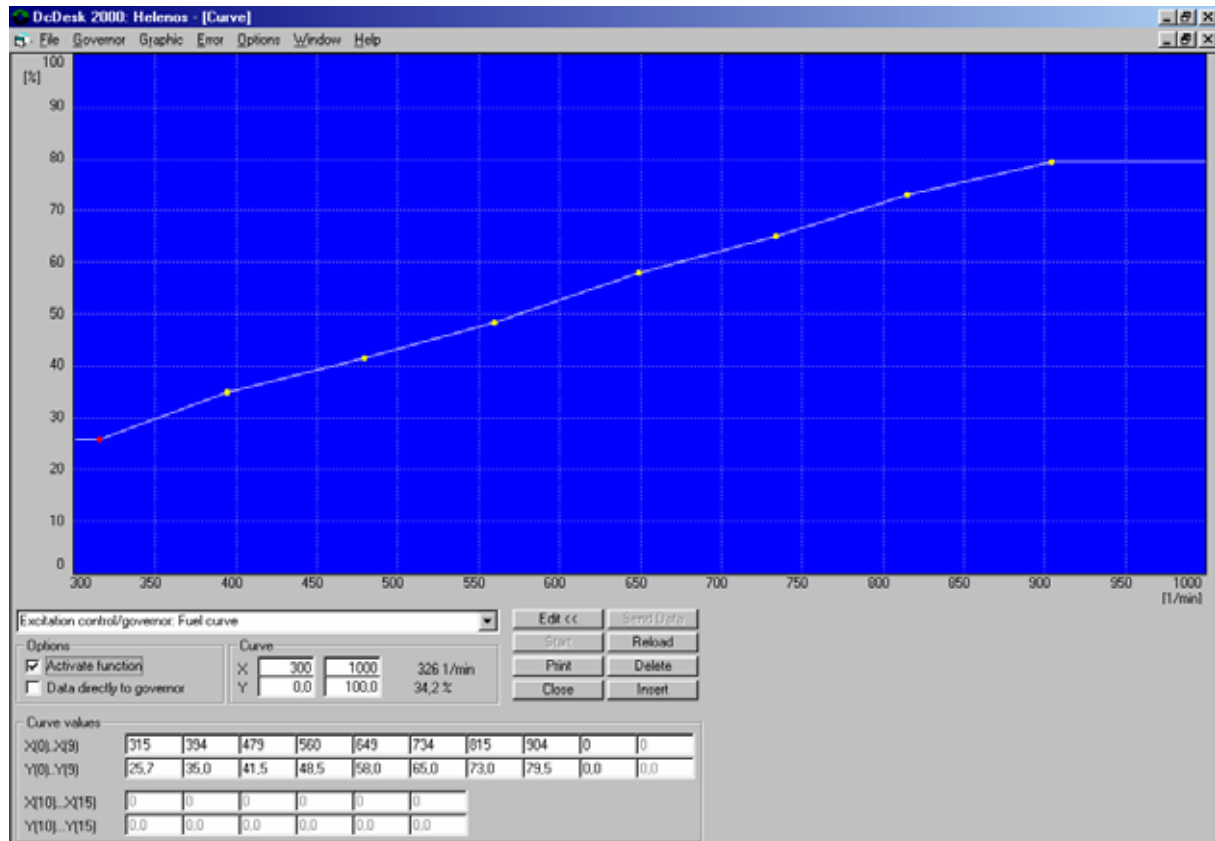

Fig. 3: DcDesk 2000 / Graphic / Curve: Excitation control/governor: Fuel curve

The result of  $\langle 2602 \text{ PowerGovFuelSetpoint} \rangle$  minus  $\langle 2300 \text{ ActPos} \rangle$  is the *input signal for the power governor*. The fuel curve in fig. 3 is the engine power setting curve for throttles 1 ... 8, adjusted on the load bank.

**Further Power governor parameters:**

- a) 620 *PowerSlideDec* = 0 ... 100 % (excitation signal decrease step per time)
- 621 *PowerSlideDuration* = 0 ... 100 s (time step for excitation signal decrease)

This is the original Heinzmann wheel slip function. On the GT26, it is used with the Woodward **Overriding Solenoid (ORS)**. The load regulator output signal (*2600 PowerControlSignal*) is reduced, when the external ORS switch signal is activated. It is connected to the governor switch input no.3 (connector pin J1), and can be monitored in:

$$2818 \text{ SwitchSlide} = 0/1 \quad (0: \text{ORS off, excitation signal is active})$$

$$(1: \text{ORS on, excitation signal is being reduced})$$

The ORS reduces the excitation during changeover of the traction motors' arrangement between serial and parallel. A smaller value in 620 will reduce the step level. A bigger value in 621 will reduce the step number per time unit. Both of these measures will slow down the unload rate and, therefore reduce the speed overshoot while unloading. On the other hand:

Decreasing the unload rate too far will not provide zero excitation during traction motor arrangement changeover.

b) Power governor PID

630 *PowerGovGain* = 0 ... 100 % (proportional governor part; Gain)

631 *PowerGovStability* = 0 ... 100 % (integral governor part; Stability)

632 *PowerGovDerivative* = 0 ... 100 % (derivative governor part)

These parameters are to be set for optimum power governor reaction and performance on the load bank. They are corresponding with 638, 639 and 7000 ... 7199 parameters.

c) 633 *PowerGovFilter* = 1 ... 255 (filter time constant for 2600 *PowerControlSetpoint*)

Value 1: no filtering; value 255: max. filtering of excitation signal. The bigger the number, the smoother the power control signal curve, but the slower the governor reaction.

d) 635 *PowerSetpPC* = 0 ... 100 % (manual setting of 2600 *PowerControlSetpoint*)

This may be used with *DcDesk 2000* to set a fixed excitation signal level. It was made for test and load adjustment purpose. Activated by setting 4635 *PowerSetpointPCOn* = 1.

e) 636 *PowerFuelOffset* = -50 ... 50 % (shift parameter for Power Fuel Setpoint Curve)

After modifications of the actuator fuel linkage, the relation between actuator position and fuel pump position may have changed. This parameter gives the opportunity to **re-adjust the whole power fuel setpoint curve** (6620 ... 6635) just by testing one speed/load out of 8 (throttles 1 ... 8) and modifying parameter 636.

The recommended load for re-adjustment is the maximum in throttle 8.

f) 637 *PowerFuelLimitForced* = 0 ... 100 % (Limitation of 2602 *PowerGovFuelSetpoint*)

During **dynamic braking**, the power must be limited to a low and constant value. This limit (from terminals 6T2/6T3) is given to the governor via switch input no. 1 (governor pin M1). It can be monitored in

2823 *SwitchPowerLimit* = 0/1 (0: no limit)

(1: power is limited to value in <637>)

g) Power governor static correction

638 *PowerStaticCorFactor* = 0 ... 100 % (factor for reduction of PID, 630 ... 632)

639 *PowerStaticCorrRange* = 0 ... 100 % (range around 2602 *PowerGovFuelSetpoint*)

The power governor PID values are reduced by (multiplied with) this factor to stabilize the Power governor within the range in <639> around the actual 2602 *PowerGovFuelSetpoint*.

h) Power governor fuel ramp

640 *PowerGovFuelRampUp* = 0 ... 800 %/s (Ramp-up rate for 2602 *PowerGovFuelSetp.*)

641 *PowerGovFuelRampDown* = 0 ... 800 %/s (Ramp-down rate for 2602)

In parameter 640, the maximum load setpoint increase rate in % actuator per second is preset.

In parameter 641, the maximum load setpoint decrease rate in % actuator per second is preset.

Activation of both ramps: 4640 *PowerGovFuelRampOn* = 1.



**Note**

These ramps effect the Power Governor Fuel Setpoint, not the excitation signal itself. The excitation signal rate depends on the power PID governor settings.

i) 642 *PowerGovMaxFuelDelta* = 0 ... 100 % (max. accepted differential input signal)

The result of <2602 *PowerGovFuelSetpoint*> minus <2300 *ActPos*> is the input signal for the power governor. It is limited to the value in parameter 642 for the power governor.

Parameter 642 limits the rate of the power governor output signal 2600 *PowerControlSetpoint*. The result will be a more stable, but slower power governor.

j) 643 *PowerGovStaticFuel* = 0 ... 100 %

644 *PowerGovStaticRed* = 0 ... 100 %

These parameters allow a reduction of 631 *PowerGovStability*, when the difference of <2602 *PowerGovFuelSetpoint*> and <2300 *ActPos*> is bigger than <643>. It is a power governor integrator limit. (Adjustment is not recommended, if not necessary. Should be done at the load bank and only, if load instability cannot be fixed otherwise.)

k) Coolant temperature depending power reduction (not in 47.0.00 software)

650 *PowerFuelLimTempDec* = 0 ... 100 % (max. reduction of 2602 *PowerGovFuelSetpoint* in % actuator position)

651 *PowerFuelLimTempLow* = -100 ... 1000 °C (reduction start temperature value)

652 *PowerFuelLimTempHigh* = -100 ... 1000 °C (max. reduction temperature value)

Between the two temperatures there is a linear interpolation.

2634 *PowerFuelLimitTemp* = ... % (actual reduction value in % of 2602 value)

2644 *PowerFuelLimitActive* = 0/1 (0: no reduction, 1: reduction active)

4650 *PowerFuelTempLimOn* = 1 (activation of this function)



**Note**

A HEINZMANN temperature sensor TS 01 28-PT1000 must be connected to the Heinzmann engine terminal box, terminals 25 and 26 (refer to HEINZMANN drawing no. ESk 2315).

l) Charge air pressure depending power limitation

Analogue to the (here not used) charge air pressure depending fuel limitation, this function is limiting 2602 *PowerGovFuelSetpoint*. It is based on the actual boost pressure value and programmed in a curve (6440 ... 6449, 6460 ... 6469).

2635 *PowerFuelLimitBoost* = ... % (actual limit value in % of 2602 value)

2645 *PowerBoostLimActive* = 0/1 (0: no limit, 1: actual limitation)

4660 *PowerFuelBoostLimOn* = 1 (activation of this function)

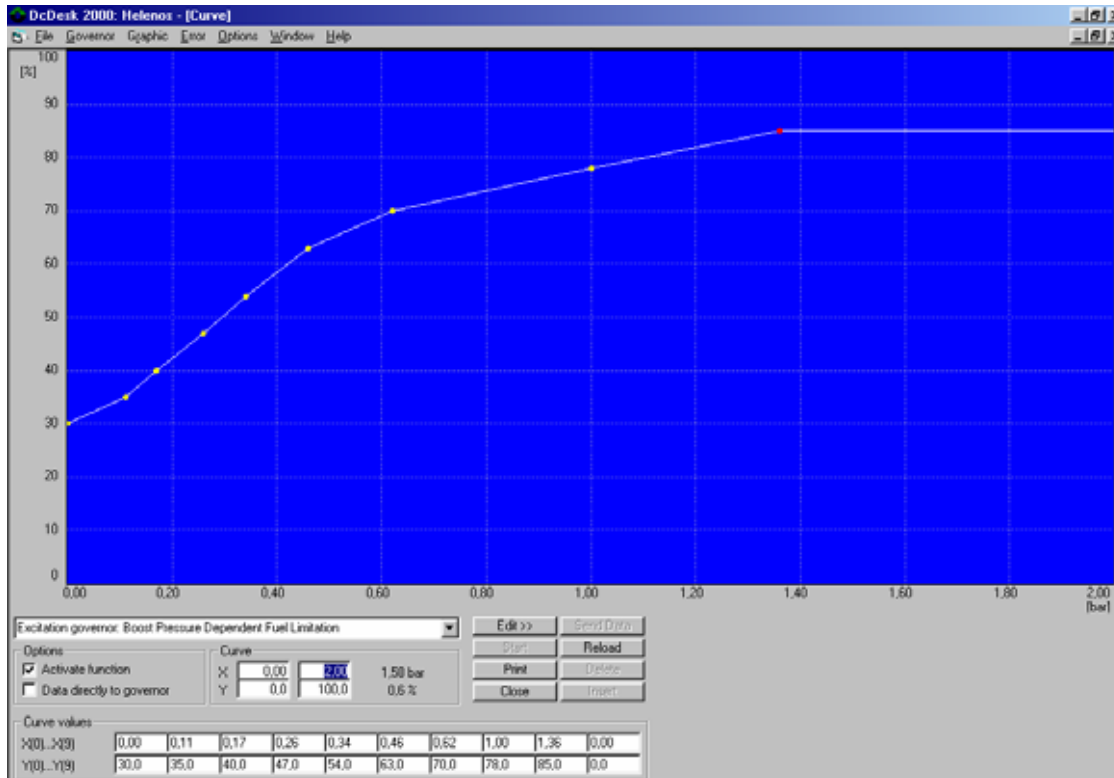
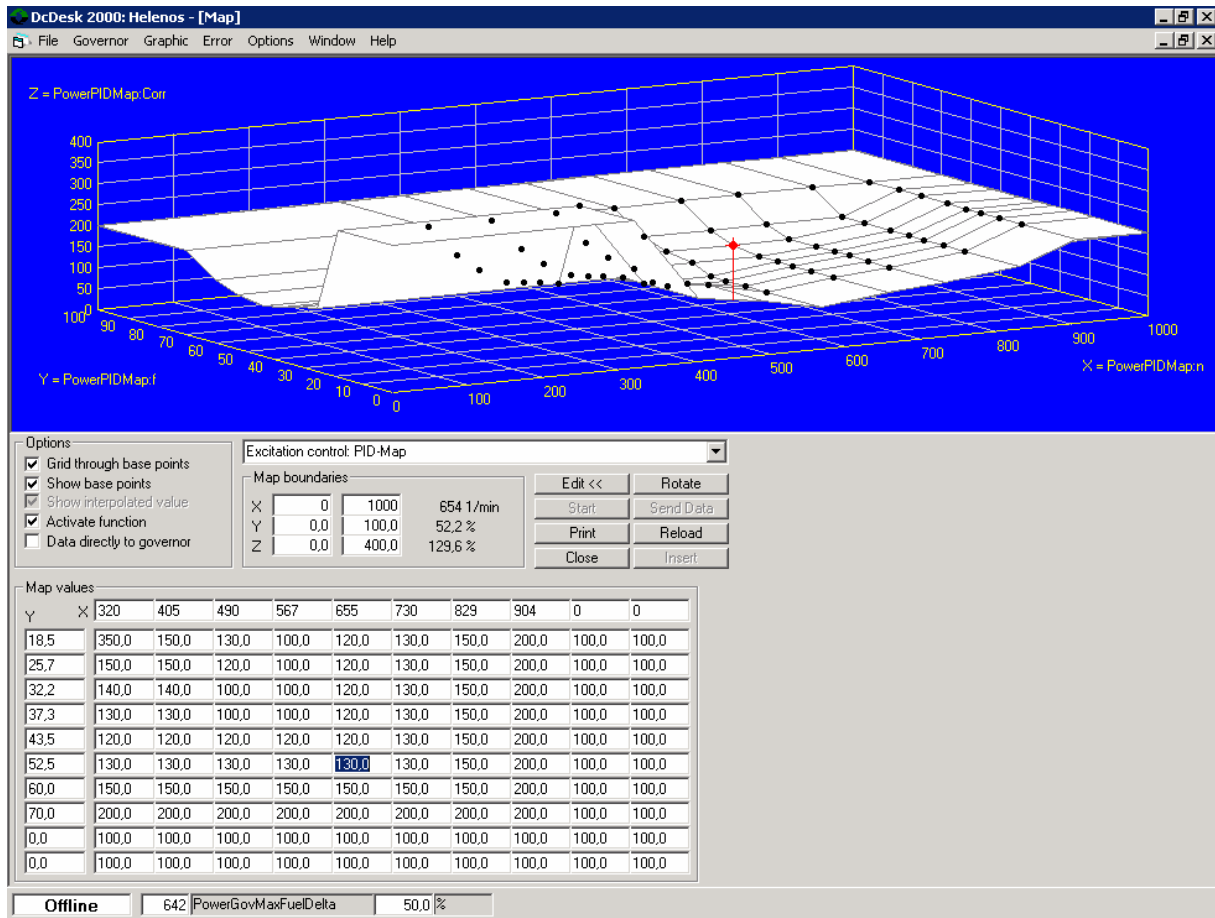

Fig. 4: DcDesk 2000 / Graphic / Curve: Excitation governor: Boost pressure dependent Fuel Limitation

m) PID map for power governor

Like the speed governor, the power governor may be affected by a speed and load depending PID map.



**Fig. 5: DcDesk 2000 / Map / Excitation control: PID map**

This map is a tool to adapt the power governor settings to the physical conditions of the locomotive over the whole speed and load range.

The X values represent actual engine speed (2000).

The Y values represent the actual power governor fuel setpoint level (2602).

The Z value is a power PID factor, related to X and Y.

Example: X = 654 rpm, Y = 52,2 % and Z = 129,6 %

The power PID (630 *PowerGovGain*, 631 *PowerGovStability*, 632 *PowerGovDerivative*) values are multiplied with 1,296. The result is a power PID increase of 29,6 % at 654 rpm and 52,2 % actuator position.

## 7 Power adjustment

The Heinzmann power governor follows a preset curve made of speed and fuel setpoint values. By altering the excitation signal 2600 *PowerControlSignal*, the actuator position 2300 *ActPos* is increased to match 2602 *PowerGovFuelSetpoint*.

The speed values are located in 6600 ... 6615 *PowerControl:n(x)*

The fuel setpoint values are to be entered in 6620 ... 6635 *PowerControl:f(y)*

This relation is displayed graphically in *DcDesk 2000* operating program.

Go ONLINE with PC and governor.

Open *DcDesk 2000 / Graphic / Curve / Excitation control/governor: Fuel curve*.

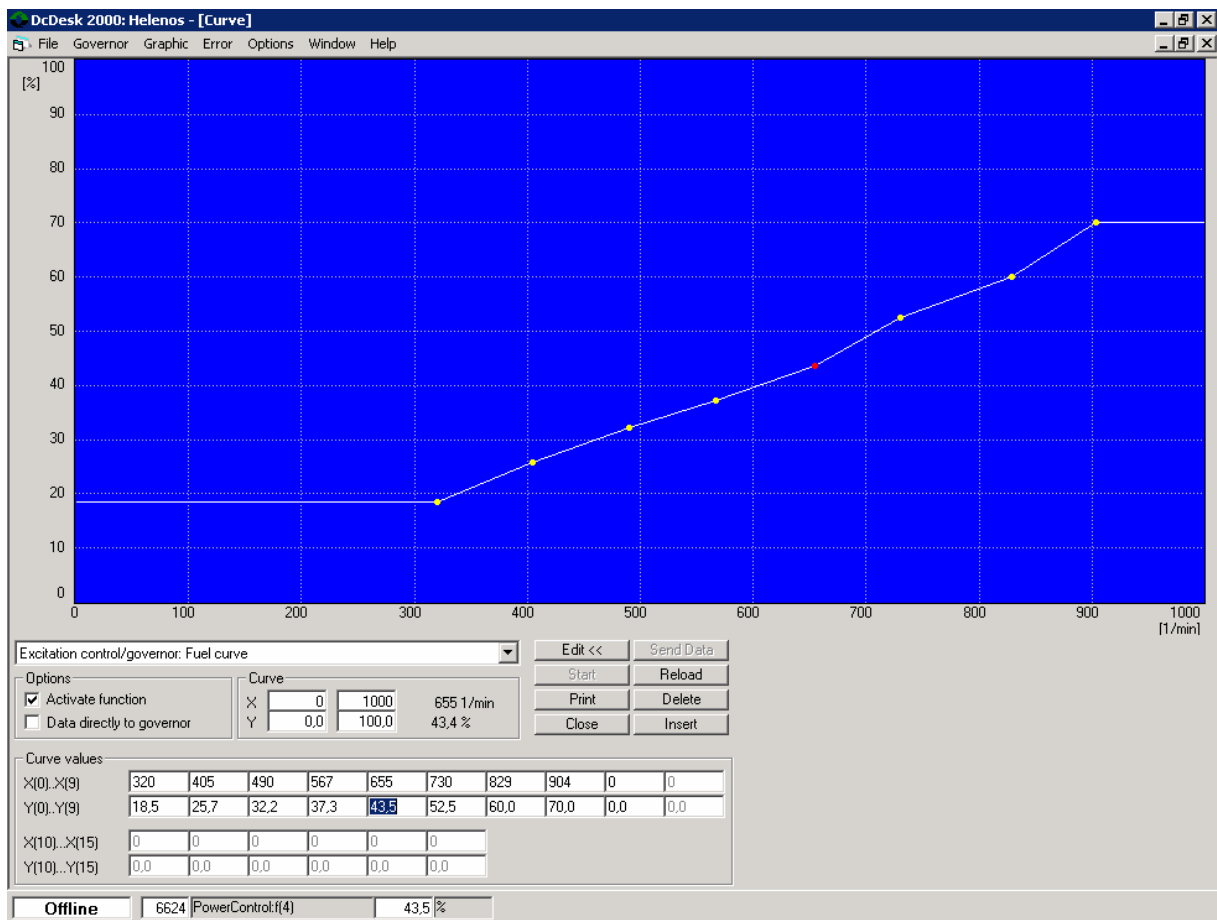

**Fig. 6: DcDesk 2000 / Graphic / Curve / Excitation control/governor: Fuel curve**



**Note**

The power adjustment should be done in stationary condition; use a load test facility, if possible. Compare actual power (product of generator DC voltage and current) to the values, given by the locomotive manufacturer or railway authority.

### Adjustment procedure:

- Set the speed throttle to no. 1 (320 rpm).

Check the options box “*Data directly to governor*” in *DcDesk 2000* curve window and adjust the power fuel setpoint level *2602 PowerGovFuelSetpoint* by modifying the curve window value *Y(0)*.

Depending on the power governor PID settings, it may take a few seconds for the excitation signal to lift the actuator position (*2300 ActPos*) and match the entered setpoint value.

- Set the speed to the next throttle no. 2 (405 rpm).

Adjust the power level using the curve window value *Y(1)*.

- Set the speed for the other throttles no. 3 ... 8 (490 ... 904 rpm).

Adjust the power level using the curve window values *Y(2) ... Y(8)*.



#### Note

As the generator power is a product of (traction motor) voltage and current, we recommend writing down voltage and current values for all throttles. Also, the governor values should be put in a chart like the following example. So, one can recall the conditions during test procedure and compare it to long-term field operation.

Adjustment and measuring values of a GT26 locomotive (example):

Throttle	Speed (rpm)	Power (kW)	Power Fuel Setpoint (%)	Boost Pressure (bar)	Excitation Signal (% PWM)*
<i>Parameter :</i>	<i>2000</i>	-	<i>2602</i>	<i>2904</i>	<i>2600</i>
<b>0</b>	<b>320</b>	<b>0</b>	<b>18,5</b>	<b>0</b>	-
<b>1</b>	<b>320</b>	<b>55</b>	<b>18,5</b>	<b>0,1</b>	...
<b>2</b>	<b>405</b>	<b>252</b>	<b>25,7</b>	<b>0,15</b>	...
<b>3</b>	<b>497</b>	<b>448</b>	<b>32,2</b>	<b>0,25</b>	...
<b>4</b>	<b>567</b>	<b>653</b>	<b>37,3</b>	<b>0,35</b>	...
<b>5</b>	<b>655</b>	<b>956</b>	<b>43,5</b>	<b>0,45</b>	...
<b>6</b>	<b>730</b>	<b>1248</b>	<b>52,5</b>	<b>0,60</b>	...
<b>7</b>	<b>829</b>	<b>1672</b>	<b>60,0</b>	<b>1,0</b>	...
<b>8</b>	<b>904</b>	<b>2122</b>	<b>70,0</b>	<b>1,35</b>	...

\*) The excitation signal *2600 PowerControlSetpoint* is the output of the Pegasus load control PID governor. The values depend on real engine operating conditions.

### Load check on track under normal operating conditions:

Go ONLINE with PC and governor.

Open *DcDesk 2000, Graphic, Curve vs. time*. Display the following values on the screen:

2000 <i>Speed</i>	= 0 ... 1000	1/min
2033 <i>SpeedSetpSelect</i>	= 0 ... 1000	1/min
2300 <i>ActPos</i>	= 0 ... 100	%
2600 <i>PowerControlSetpoint</i>	= 0 ... 100	% (excitation signal)
2602 <i>PowerGovFuelSetpoint</i>	= 0 ... 100	% (actuator setpoint from power fuel curve)
2634 <i>PowerFuelLimitTemp</i>	= 0 ... 100	% (cooling water depending power limit)
2635 <i>PowerFuelLimitBoost</i>	= 0 ... 100	% (boost pressure depending power limit)
2701 <i>FuelLimitMax</i>	= 0 ... 100	% (max. actual fuel limit)
2904 <i>BoostPressure</i>	= 0 ... 2	bar (actual charge air pressure value)
2905 <i>OilPressure</i>	= 0 ... 10	bar (actual lube oil pressure value)
2907 <i>CoolantTemp</i>	= 0 ... 100	° C (actual cooling water temperature)

Additional informations about power limitation are provided by the following measuring values:

2640 <i>PowerLimitMaxActive</i>	=	0/1
2641 <i>PowerFuelLimActive</i>	=	0/1
2642 <i>PowerForcedLimActive</i>	=	0/1
2643 <i>PowerSlideLimActive</i>	=	0/1
2644 <i>PowerTempLimActive</i>	=	0/1
2645 <i>PowerBoostLimActive</i>	=	0/1

The switch input status may be helpful as well:

2815 <i>SwitchSpeedFix1</i>	=	0/1	(low idle speed)
2818 <i>SwitchSlide</i>	=	0/1	(ORS)
2819 <i>SwitchNotch3</i>	=	0/1	(solenoid B)
2820 <i>SwitchNotch2</i>	=	0/1	(solenoid C)
2821 <i>SwitchNotch1</i>	=	0/1	(solenoid D, inverted)
2822 <i>SwitchNotch0</i>	=	0/1	(solenoid A)
2823 <i>SwitchPowerLimit</i>	=	0/1	(dynamic brake)
2828 <i>SwitchErrorReset</i>	=	0/1	(pushbutton)
3350 <i>Notch</i>	=	0 ... 8	(throttle positions 0 ... 8)



#### Note

The *DcDesk 2000 Curve vs. time* window can display up to 10 curves graphically and 10 more measuring values in numbers. The following screenshot shows the dynamic performance of the speed / load control system with the adjusted values. (As long as the speed setpoint is changing, steady state condition will not be reached. Reason for this behaviour is the combination of speed and load control functions.)

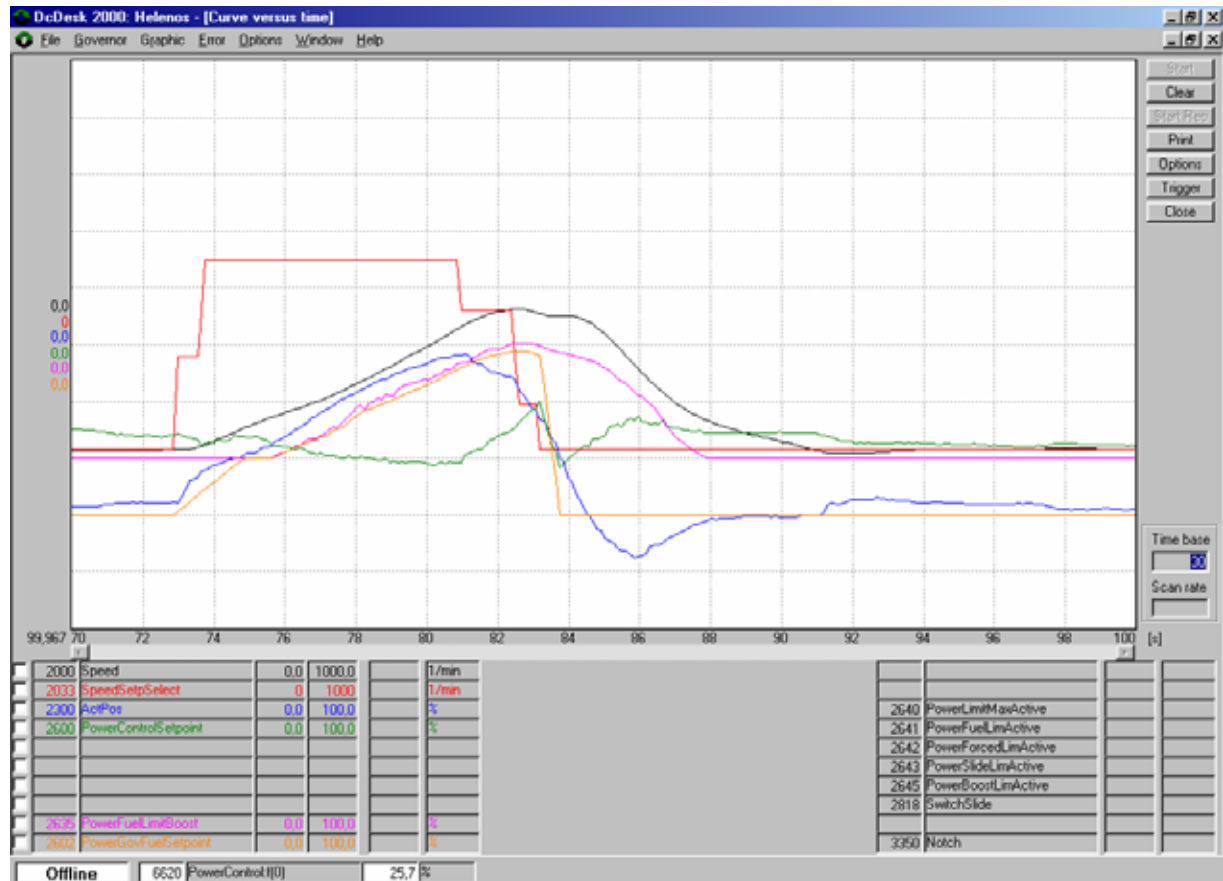

Fig. 7: DcDesk 2000 / Graphic / Curve vs. time

In steady state condition, the curves 2000 *Speed* and 2033 *SpeedSetpointSelect* have to match. The speed governor PID (100 ... 102) are responsible for this, using the actuator position setpoint 2330 *ActPosSetpoint*.

Speed ramp parameters: 230 *SpeedRamp...* ff.

The curves 2602 *PowerGovernorFuelSetpoint* and 2300 *ActPos* have to match. The power governor PID (630 ... 632) are responsible for this, using the excitation signal 2600 *PowerControlSetpoint*.

Fuel setpoint ramp parameters: 640, 641 *PowerGovFuelRamp...*

In case of low charge air pressure, 2602 *PowerGovernorFuelSetpoint* is limited by 2635 *PowerFuelLimitBoost*.

During dynamic brake operation, parameter 637 *PowerFuelLimitForced* is the value limiting 2602 *PowerGovernorFuelSetpoint*.

While ORS (overriding solenoid) is activated, the excitation signal 2600 *PowerControlSetpoint* will be limited directly. The limit rate is given by 620 *PowerSlideDec* and 621 *PowerSlideDuration*.

## 8 System components

### 8.1 Sensors

Sensor	Engine speed	Cooling media temperature	Charge air pressure	Lube oil pressure
HEINZMANN part number	IA 22-76	TS 01-28-PT1000	DSG 04-2	DSO 01-10
Connector	SV 6-IA-2K 2-pin	SV 6-IA-2K 2-pin	2 terminals	DIN 43650 A 2 wire system
Measuring mode	inductive sensor	PT1000, passive	active	Active
Measuring range	5..12.000 Hz	-50..+150°C	0 ... 2,0 bar	0... 6,0 bar
Supply voltage range	no supply voltage required	passive	10..36 V DC	10..34 V DC
Output signal range	0,5..10 V AC	about 700..1500 Ohm	4..20 mA	4..20 mA
Operating temperature range	-55..+120°C	-50..+150°C	-40..+100°C	-25..+125°C
Protection grade	IP 55	IP 65	IP 65	IP 65
Vibration		< 20 g, 10..300 Hz	< 2 g, 5..500 Hz	< 20 g, 10..300 Hz
Shock		< 50 g, 11 ms half sine	< 50 g, 11 ms half sine	< 50 g, 11 ms half sine

#### 8.1.1 Speed pickup IA 22-76

The distance between speed pickup surface and measuring gear tooth must be 2 ... 3 mm. (1,5 turn back from contact with tooth.)

Type	EDV no.	L(mm)	Thread G	Remarks
22 - 76	602-80-012-00	76	M 24 x 1,5	cable connector type SV6-IA-2K (EDV no.: 010 02 170 00)

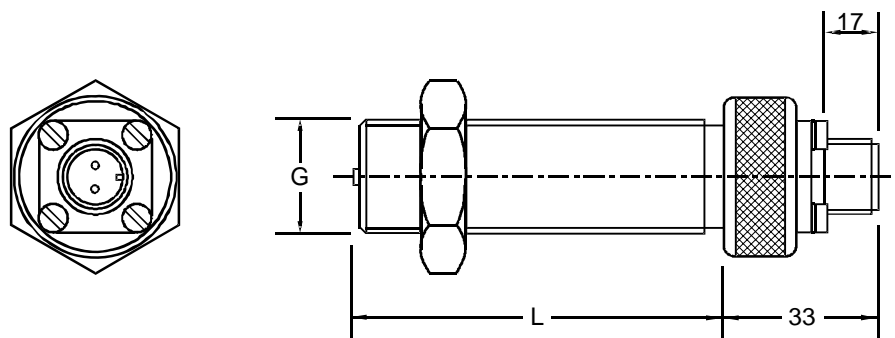

Fig. 8: IA 22-76 speed pickup

### 8.1.2 Cooling media temperature sensor TS 01-28-PT1000

Measuring range	-50°C bis +150°C
Accuracy	±1,5°C
Resistance at 25 °C (R25)	1000 Ohm ±0,5 %
Max. supply voltage	5 V
Max. supply current	3 mA
Recommended supply current	ca. 1 mA
Time constant in liquid media	ca. 13 Sekunden
Connector temp. range	-40°C bis +105°C
Protection grade	IP 65
Vibration	< 20 g, 10..300 Hz
Shock	< 50 g, 11 ms half sine
Fixation torque	50 Nm ±15 %
Connector type	SV 6 - IA - 2K (EDV no.: 010 02 170 00)

Temperature sensor	EDV no.	L1 (mm)	L2 (mm)	Thread G
TS 01-28 - PT 1000	600-00-053-00	12	16	M 14 x 1,5

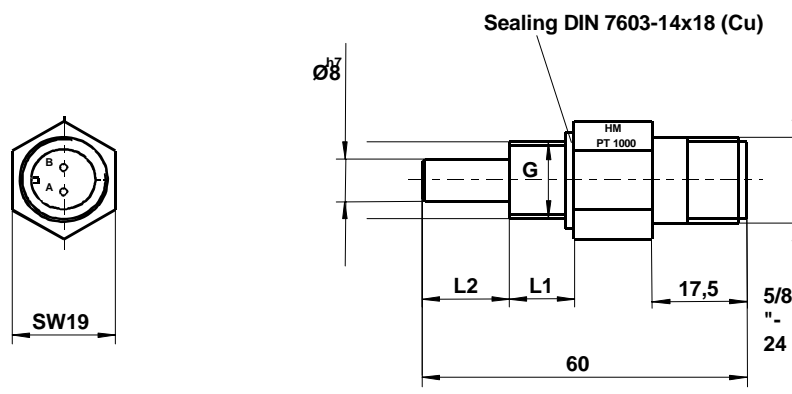

Fig. 9: Temperature sensor TS 01-28-PT1000

### 8.1.3 Oil pressure sensor

Measuring range	0 ... 10 bar
Overpressure	20 bar
Supply voltage	10..34 V DC
Output signal	4..20 mA
Storage temperature	-25°C bis +85°C
Ambient operating temperature	-25°C bis +85°C
Oil temperature	-25°C bis +125°C
Protection grade	IP 65
Vibration	< 6 g, 20..2000 Hz
Shock	< 50 g, 11 ms half sine
Fixation torque	max. 25 Nm
Connection	DIN 43650-A, 2 wire system

Oil pressure sensor	EDV no.	Max. operating pressure (bar rel.)
DSO 01-10	600-00-058-01	10

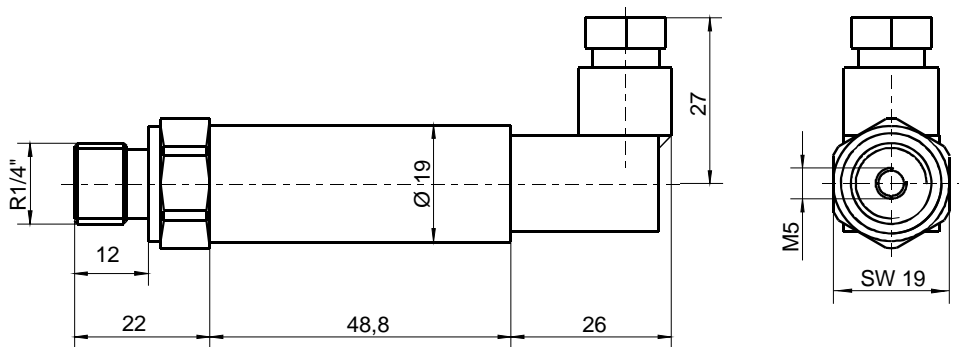

Fig. 10: Oil pressure sensor DSO 01-10

(Coolant water pressure 6 bar sensor data are similar.)

### 8.1.4 Boost pressure sensor

Measuring range	0 ... 2,0 bar
Overpressure	4 bar
Supply voltage	10..36 V DC
Output signal	4..20 mA
Storage temperature	-55°C bis +100°C
Ambient operating temperature	-40°C bis +100°C
Protection grade	IP 65
Vibration	< 2 g, 5 ... 500 Hz
Shock	< 50 g, 11 ms Halbsinus
Connection	2 wire, terminals



## 8.2 Control unit PEGASOS DC 40.2 - 01

### 8.2.1 Technical data

Supply voltage	28 ... 140 VDC
Fuse	6 A (slow)
Current consumption	~ 200 mA + actuator current
Speed input frequency range	200 ... 12.000 Hz
Speed accuracy	±0.25 %
Frequency drift over temperature at a frequenz over 500 Hz between -40°C and +70°C	±1 %
Storage temperatur	-55°C ... +85°C
Ambient operating temperature	-40°C ... +70°C
Humidity	up to 100 %
Protection grade	IP 44
Weight	about 15 kg

### 8.2.2 Dimensions

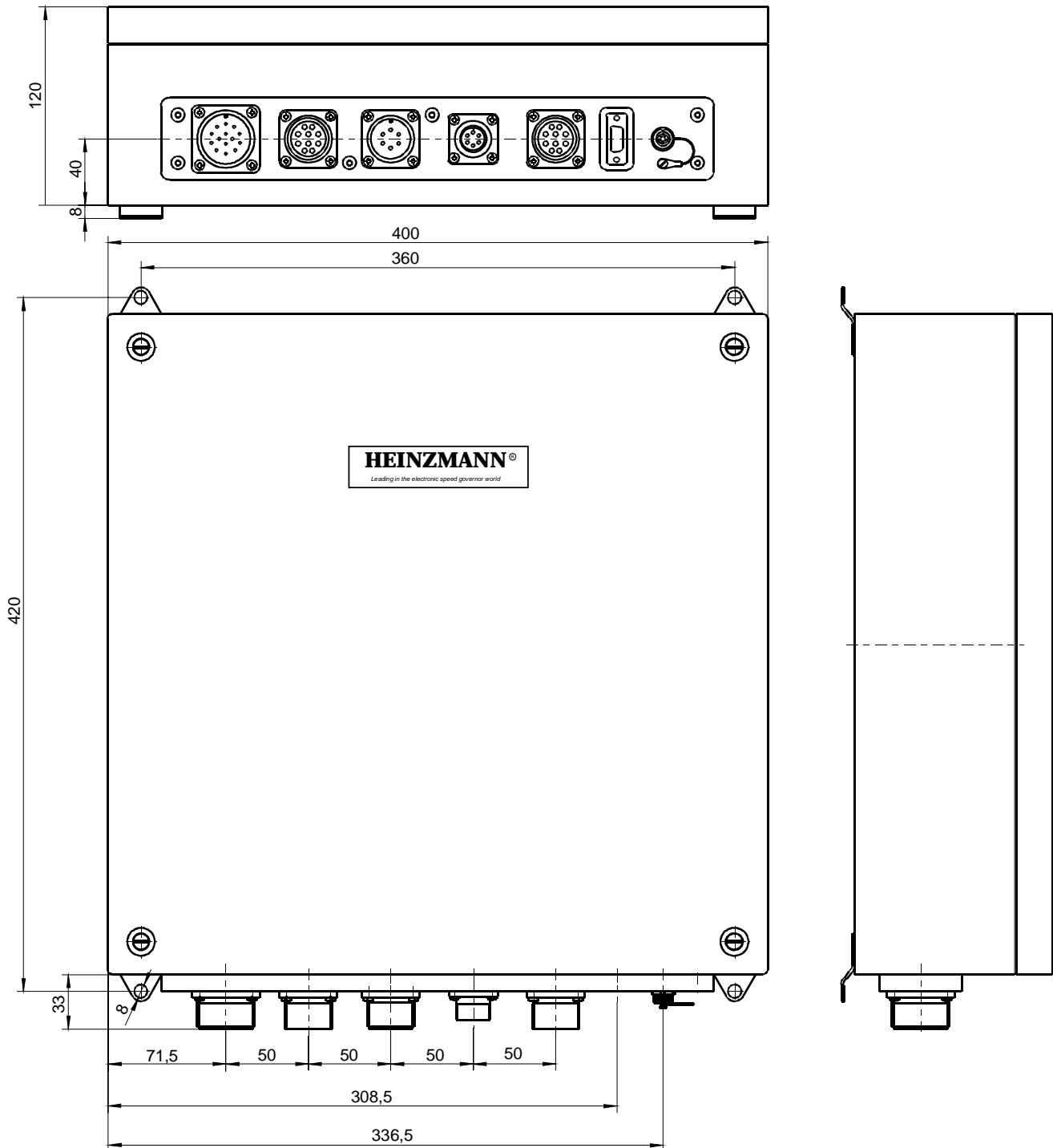

**Fig. 12: Panel (Rittal KL 1511) with PEGASOS digital controller**

For installation in the GT26 fan section, an additional protective panel with optional signal lamps is to be used.

### 8.2.3 Locomotive interface

The LCI 01-2 locomotive interface is a part of the PEGASOS control unit. It consists of a mother board and a number of interface cards for digital inputs, analogue outputs and relay outputs. The interface cards are responsible for signal conversion from 74 to 24 VDC level, as well as for potential separation between locomotive and governor.

One of the interface boards is the excitation signal amplifier (position X9). It converts the 4 ... 20 mA excitation signal from the governor (*2600 PowerControlSetpoint*) into an electronic potentiometer position, replacing the Woodward PGR 1,5 kOhm rheostat.

For more information, see 9. Electric connection and 11. Troubleshooting.

## 8.3 StG 40 actuator

### 8.3.1 Design and mode of operation

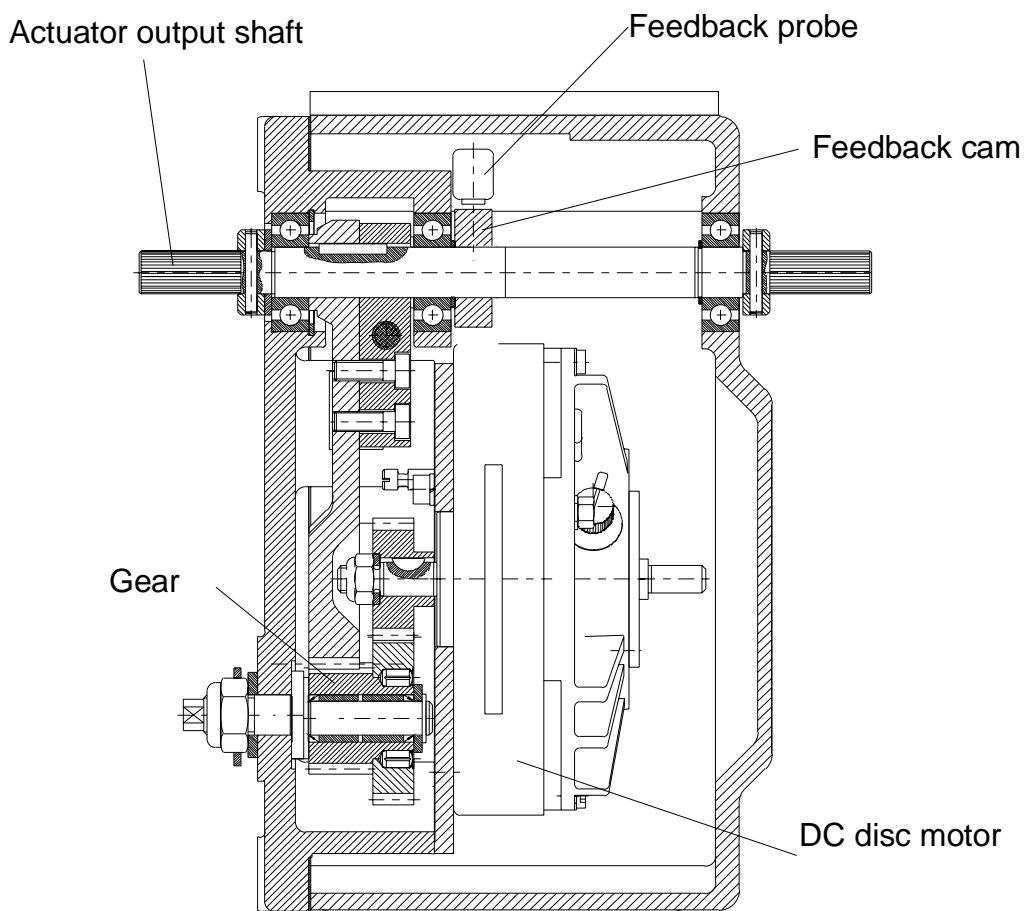

**Fig. 13: StG 40 actuator**

The power source of the actuators are DC disk motors, whose torque is transmitted to the output shaft via an intermediate gear. By using special materials and long-term lubricants the actuators are **maintenance-free for up to 20,000 running hours**.

A feedback cam is mounted on the control output shaft for contactless sensing by a probe, transmitting the accurate position of the output shaft to the control unit.

When the actuator is driven to a mechanical stop, e.g., due to overload of the diesel engine or failure of a cylinder, current limitation will take effect after about 20 seconds and reduce current to the actuator to a value, sufficiently low to prevent damage to the actuator. This actuator design delivers the following benefits:

- High torque in either direction.
- Extremely low current consumption in steady-state operation and only short-term higher current consumption on load changes.
- Indifference to slow voltage changes of power supply (abrupt voltage changes will cause speed instability).

### 8.3.2 Installation

The actuator is mounted on the engine instead of the Woodward PG-R governor. The following HEINZMANN brackets are to be used:

PLATTE (steel plate)	SK-12-93-00
PLATTE (aluminium plate)	SK-12-94-00

HEINZMANN parts for the fuel linkage connection are:

REGULIERHEBEL (lever)	505-17-001-03
BUCHSE (bush)	SK-12-95-00

For fuel linkage installation and adjustment, refer to 5. System setup.

For injector maintenance, refer to 10.2. Injector linkage adjustment.

### 8.3.3 Technical data - StG 40 actuator

	StG 40 - 01
Effective rotational angle of output shaft	42°
Maximum torque at output shaft (direction stop)	approx. 44 Nm
Holding moment during current limitation	approx. 22 Nm
Response time 0–100% off load	approx. 190 ms
Storage temperature	-55°C to +110°C
Ambient temperature during operation	-25°C to +90°C
Ambient temperature special version	-40°C to +90°C
Air humidity	up to 100 %
Protection grade	IP 44
Weight without bracket	approx. 12,3 kg

### 8.3.4 StG 40 dimensions

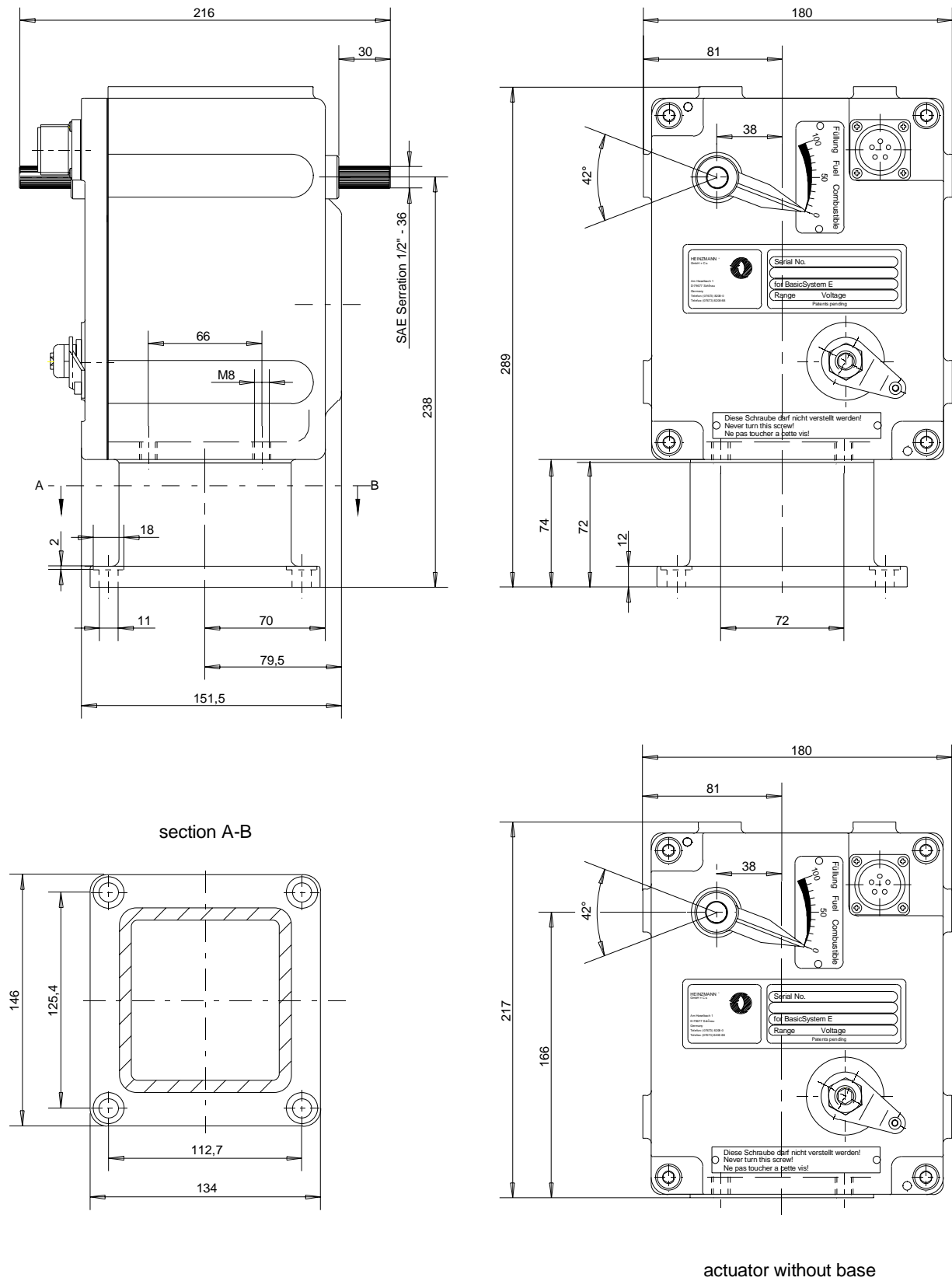

actuator without base

Fig. 1: StG 40-10 dimensions

## 9 Electric connection

### 9.1 General instructions

Diesel-electric locomotives operate at generator voltages of several hundred Volts and voltage peaks up to kilovolts. Therefore, HEINZMANN electronics as well as the sensors, must be installed electrically isolated from the on-board supply system. The following aspects should be considered:

- Power supply for the governor is provided by a power DC/DC converter with internal overvoltage filter. The voltage is converted into 24 VDC.
- Power supply for the engine sensors is taken from the governor (internal 24 V supply voltage, or 5 V reference voltage), otherwise all signals must be transmitted to the governor via potential separators.
- Digital inputs, as well as digital and analogue outputs, are isolated electrically from the on-board supply by a LCI 01-2 Locomotive Interface within the Pegasos control unit.
- In order to avoid earth loops, the governor wiring must not establish any additional connection between engine ground and negative on-board supply.
- It is imperative that the housing of the Pegasos control unit be connected to vehicle ground. With the use of elastic suspension, earthing cables must be provided (cable size minimum 4 mm<sup>2</sup>).
- To prevent electromagnetic interference, the shielding of either cable ends should have mass (frame) connection. This applies to all shields of the cables from the governor to sensors, actuator and accessory devices.
- If there exists a potential difference between the governor housing and any of these components, a compensation line must be installed from the governor housing to each respective component, in order to avoid transient currents across the shield.
- In case, electro-magnetic interference problems cannot be eliminated by this connection method, the cable shields may be connected to the on-board voltage negative potential after due consultation with Heinzmann. In this case the shield is to be connected only on one side (control unit).
- All signals and cable shields, that have to be passed through an engine terminal box, must be isolated from the terminal box's housing.

## 9.2 Connecting diagram of PEGASOS control system

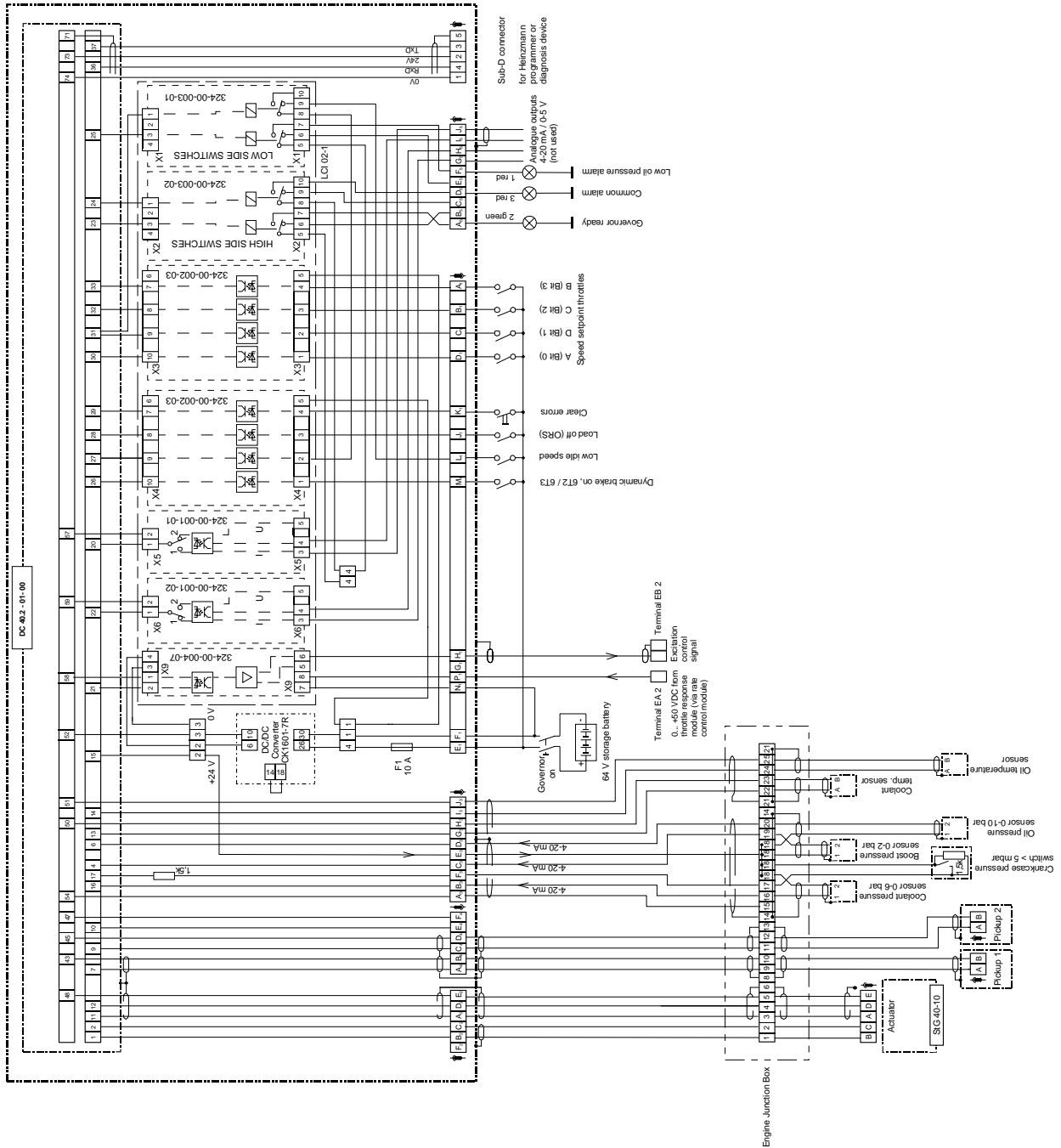

Fig. 15: PEGASOS connecting diagram

### 9.3 Cable dimensions

1. Power supply (connector 1, pins E, F):

64/74 VDC locomotive supply:	up to 10 m	1,5 mm <sup>2</sup>
	over 10 m	2,5 mm <sup>2</sup>

2. Excitation signal (Stecker 1, pins G, H, N, P):

GT26 locomotives:	at least	0,75 mm <sup>2</sup>
	(shielded cable)	

3. Actuator drive (connector 2, pins B, C):

	up to 15 m	2,5 mm <sup>2</sup>
	over 15 m	4,0 mm <sup>2</sup>

The cable should be as short as possible and not longer than 25 m.

4. All other cables: at least 0,75 mm<sup>2</sup>

All cables may be supplied by HEINZMANN. Speed pickup and actuator cables should be HEINZMANN made, for these connections are most critical. Soldering and shield connections at the CANNON connectors require accuracy and experience.

All cables wired to the engine are to be protected from overheating, chemical substances (lube oil) and damage. The use of flexible conduits is recommended. Otherwise, special cable material must be used (e.g. Teflon cable).

### 9.4 Cable harness

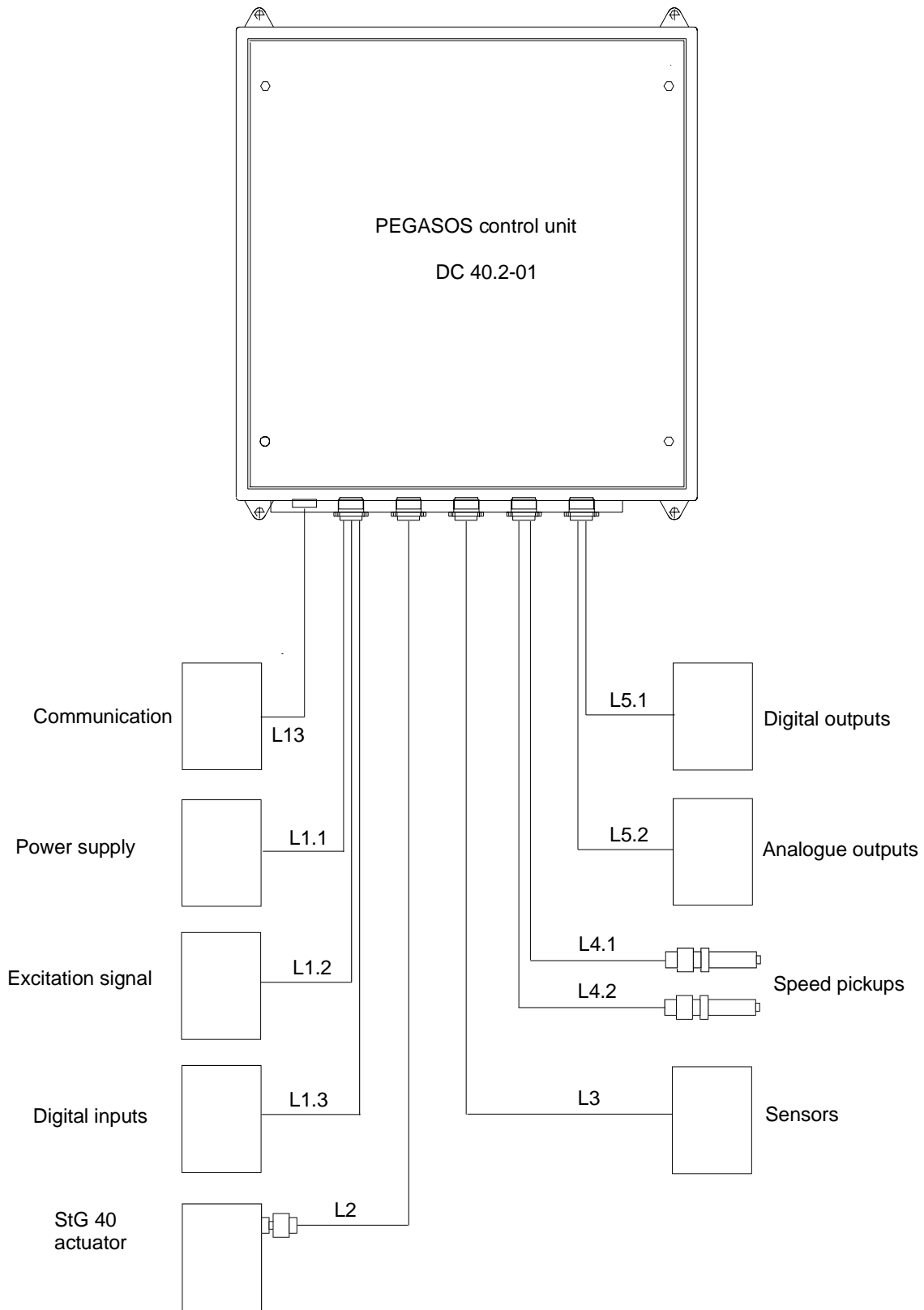

**Fig. 16: Cable harness with identifier numbers**

### 9.5 Connector types and numbers

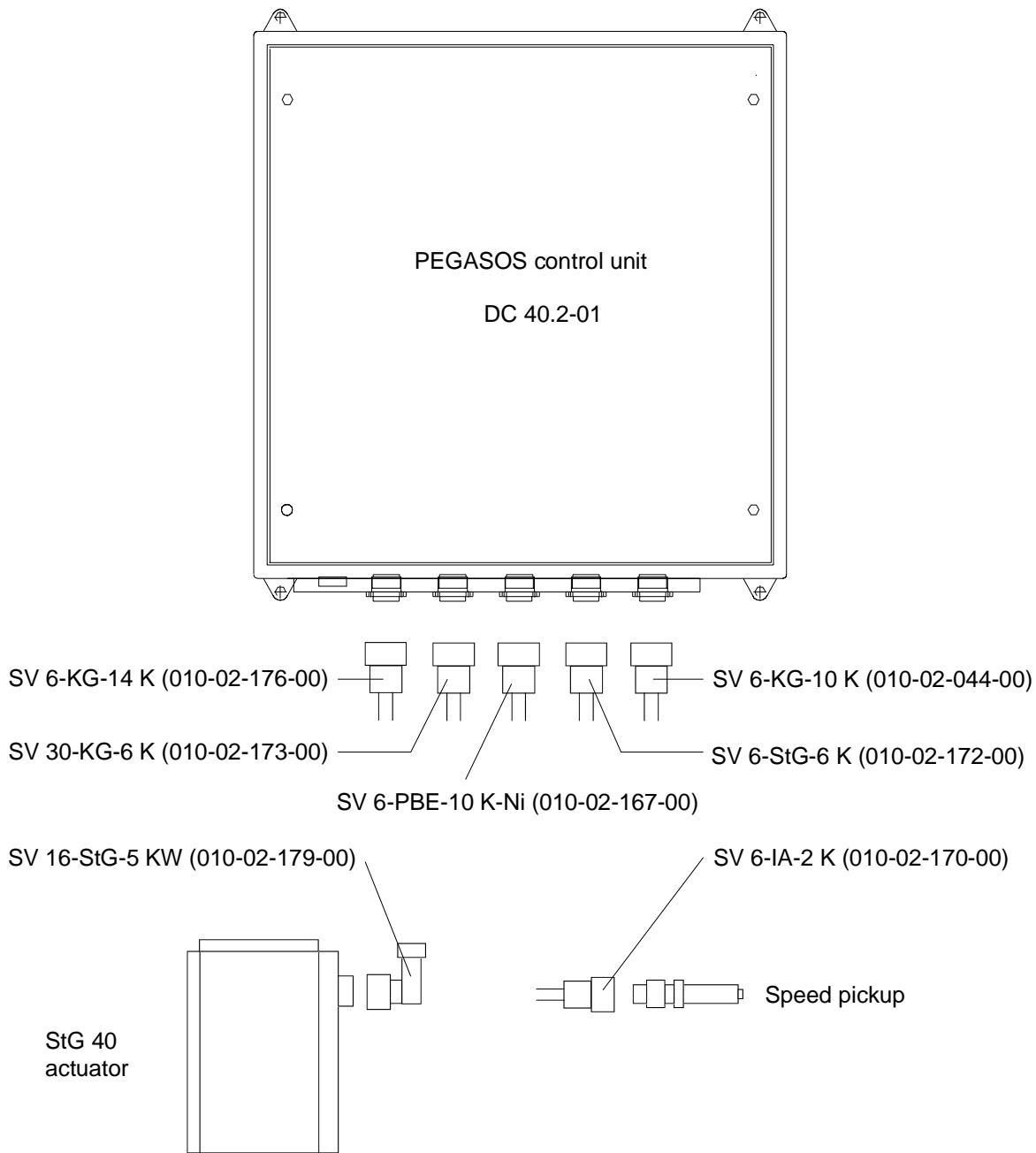

**Fig. 17: Connector types and numbers**

## 10 Periodical governor inspection and maintenance

The following chapter describes necessary actions concerning inspection and maintenance.

### 10.1 PEGASOS maintenance

1. The Heinzmann **PEGASOS controller** DG 40.2-01 for GT26CW locomotive is located in the cooling system section under the AC cooling fans, next to the air compression section. Every time the fan section is opened, the panel box should be cleaned.

If necessary, replace defective bulbs of indicator lamps (60 V, 5 W).

2. The **StG 40-10 actuator** is an electric actuator with contactless position feedback.

During engine inspections, check the actuator mounting screw connections.

Check connections of lever arm and fuel linkage. - Screws must be securely fastened.

Linkage must move easily without touching the actuator housing at any travel.

Actuator 0 % position must coincide with fuel linkage zero position.

Cable connector must be fixed correctly and free from lube oil.

In case of governor feedback error, check and clean the connector. Remove linkage and carry out automatic actuator adjustment. Reinstall linkage carefully.

Automatic actuator adjustment must be repeated every 6 months, in order to ensure a proper feedback signal.



**Note**

The StG 40-10 actuator is to be replaced every 15 ... 20,000 running hours, depending on running conditions (temperature, vibration, humidity, pollution).

3. The **IA 22-76 engine speed pickups** (M24x1,5 thread) are placed at the flywheel next to the starting gear. During engine inspections, check the 2 pickup connectors for correct fixation. In case of starting problems or governor pickup errors, remove speed pickups.

Check the pickup connectors for lube oil pollution, clean if necessary.

Clean pickup measuring surface, replace in case of damages and re-insert as follows:

- Screw pickup clockwise until it contacts the flywheel teeth.
- Turn back 1 ½ rotation (distance: 2 ... 2,5 mm) and lock counter nut.
- Connect cable plug and fix it carefully with pipe pliers (do not apply high torque!).

4. The **DSO 01-10 lube oil pressure sensor** (0 ... 10 bar) is an essential part for correct governor function. During engine inspections, check the pipe connections for leakiness. Touch sensor body and cable connector. Both must be stable and fixed correctly.



**Note**

The connector must be locked with it's screw.

If sensor is damaged by vibrations, replacement is necessary.

Operation depends on this sensor's signal.

5. **DSG 04-2 charge air pressure sensor** (0 ... 2 bar): During engine inspections, check the cable for damages and the external and internal air pipe connections for leakiness.

6. The **engine terminal box** is located on the left-hand side of the locomotive, near the lube oil strainer. All sensor cables and the actuator cables are interconnected there.

During engine inspections, check the cable entries for damages. Open the terminal box and check for lube oil pollution. Clean if necessary.

7. For **cable set** details refer to the HEINZMANN wiring diagram ESk 2315 (see also 9 Electric connection). During engine inspections, the cables should be verified to be fixed correctly with cable ties. Mechanical damages of cable conduits and cables inside must be repaired.

**Contact Pear Danesh Co., Tehran, for assistance and spare parts.**

## 10.2 Injector linkage adjustment

The injector linkage adjustment procedure for GM 645E3 16 cylinder diesel engines is described in EMD Engine Maintenance Manual.

Original equipment: Woodward 8466096 PG-R hydraulic speed governor

Retrofit system: HEINZMANN PEGASOS digital electronic speed governor.

Refer to EMD Engine Maintenance Manual, page 11-6 ff.,  
chapter: INJECTOR LINKAGE / DESCRIPTION

Additional information for Heinzmann PEGASOS:

The fuel linkage arrangement is similar to the Woodward PG-R governor.

The PG-R governor is replaced by an electrically driven StG 40-10 Heinzmann actuator, whose mounting bracket provides the same output shaft position as shown in EMD Engine Maintenance Manual, Fig. 11-9 *Injector linkage*.

The StG 40-10 has an angular travel of 42°.

The actuator is fitted with an angularly adjustable lever arm.

The utilized lever arm length between actuator output shaft and the two injector control rods' mounting point is 85 mm (given by the two holes in the HEINZMANN lever).

The basic arrangement is shown in the following schematic drawing:

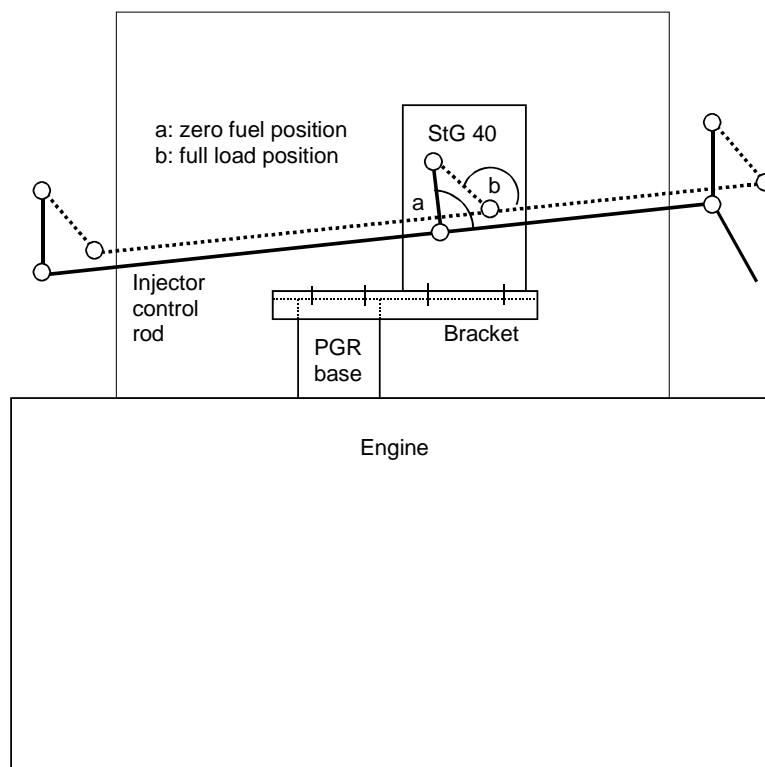

**Fig. 18: Fuel linkage arrangement**

## MAINTENANCE

Refer to Engine Maintenance Manual, page 11-7.

## SETTING INJECTOR RACKS

Refer to Engine Maintenance Manual, page 11-7 including “NOTE”, right column:

... *Set the injector rack on the engine as follows:*

1. *Install the injector linkage setting jack, Fig. 11-10.*

The following points describe the *different way of setting the Heinzmann PEGASOS governor* to the correct injector adjustment position:

2. Establish communication between *DcDesk 2000* PC program or Heinzmann hand programmer and the PEGASOS control unit.

Select measuring value **2300 ActPos** (actuator position) in *DcDesk 2000*.

*Adjust the injector linkage setting jack until the measuring value 2300 shows position x from the table (see calculation procedure below):*

Governor	stop position	full load position	injector adjustment position
Woodward PGR	1.96 in	0.8 in	1.00 in
Heinzmann PEGASOS	0 %	f (e.g. 70 %)	x (calculation below)

#### Calculation of actuator position x for injector adjustment:

Relation between PG-R and StG 40 travel:

$$1.96'' \cong 0 \% \quad (\text{stop})$$

$$1.0'' \cong x \quad (\text{adjustment})$$

$$0.8'' \cong f \quad (\text{full load})$$

$$(1.96'' - 1.00'') / (1.96'' - 0.8'') = (0 \% - x) / (0 \% - f)$$

$$x = (0.96'' / 1.16'') \cdot f$$

$$x = 0.76 \cdot f$$

$$x = 0.828 \cdot f \quad \text{with } f = 70 \% \text{ (example)*}$$

$$\underline{x = 57.93 \%}$$

\*) The value for f is taken from the Heinzmann excitation governor fuel curve, adjusted on the load test stand. The values for full load in throttle 8 are set in:

$$6607 \text{ PowerControl:n(7)} = 904 \text{ rpm}$$

$$6627 \text{ PowerControl:f (7)} = 70 \% \text{ (example)}$$

(The 6627 value is slightly different for every single installation and must be taken from the locomotive's parameter settings.)

3. Use the injector rack gauge, Fig.11-11, to set the racks within the setting range marks on the gauge. (. . .)

**Attention:**

After checking/adjusting the injector rack position, pull the fuel linkage to zero fuel and check the HEINZMANN actuator position. **Actuator must be in “0 %” position.**

If actuator is not in “0 %” position, loosen actuator lever clamping device (bush), adjust actuator position to “0 %” and fix again carefully.

The actuator clamping device is shown in the following drawing:

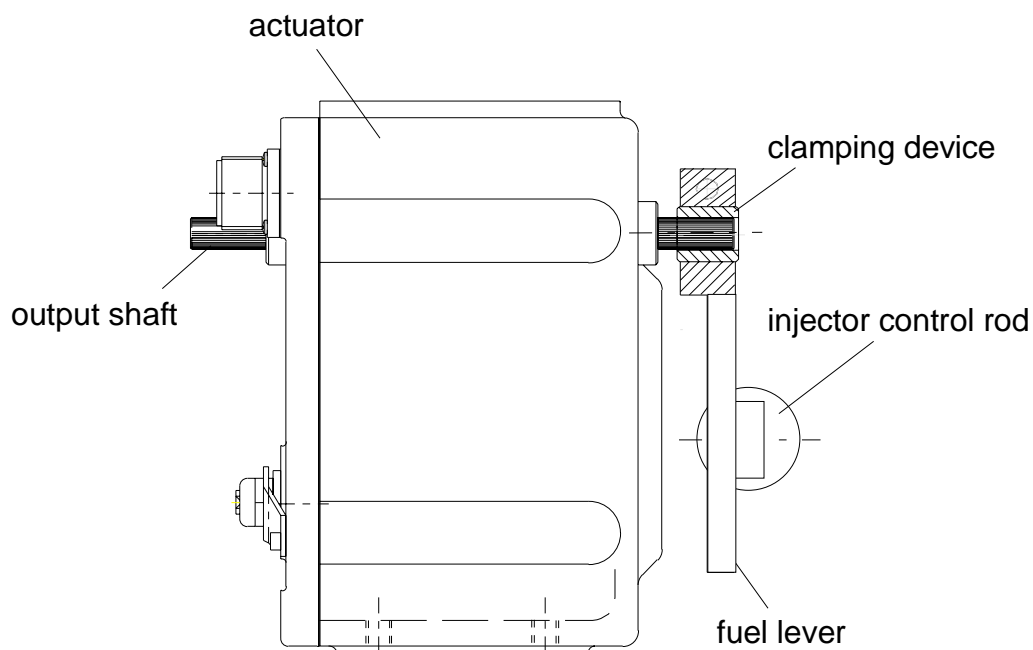

**Fig. 19: Adjustable HEINZMANN lever**

(In case of any misunderstanding or nonconformity to the original instructions in the EMD Engine Maintenance Manual, the EMD instructions are to be obeyed.)

## 11 Troubleshooting

### 11.1 Control box indicators

The Heinzmann PEGASOS controller for the GT26CW locomotive is located in the cooling system section under the AC cooling fans, next to the air compression section. It is built in a panel box with three indicator lamps (location may be different). These lamps give informations about the system status as follows:

Lamp combination	Lamp 1 (left red)	Lamp 2 (green)	Lamp 3 (red right)	System status
1	off	off	off	Power supply off
2	off	on	off	Governor ready
3	off	on	on	Maintenance required, operation is possible
4	off	off	on	Emergency stop, reset required
5	on	on	on	Low oil pressure shutdown, restart is possible
6	on	off	on	Low oil pressure shutdown, reset required

#### Action to be taken: Lamp combination no. ...

1: Turn on 64 VDC power supply voltage for the governor system.

If all lights remains off, open the box, check voltage between 10 A governor fuse input (positive) and terminal 1 (negative). Check 10 A fuse and replace, if necessary. Check bulbs and replace, if necessary (60 V, 5 W).

2: Governor is ready for engine start (normal status).

3: The engine is able to run without and with load. As soon as possible, the governor periphery

should be looked after:

**Charge air pressure sensor:** Check wiring in DSG 04-2 sensor box and to control box. Signal must be 4 mA while engine is stopped. Fix wiring or replace sensor box, if necessary.

**Speed pickups:** If one of the pickups has failed, check connector and wiring, clean pickup surface and re-adjust distance to flywheel (1,5 turns = 2 ... 2,5 mm).

The internal pickup resistance may be tested with an Ohm meter. It must be about 52 Ohm.

4: There are three possible reasons for this lamp combination. Find out using *DcDesk 2000*, *Error Memory*. The following causes are possible:

**Overspeed shutdown:** Check linkage from actuator to fuel pumps, which must be tightened correctly and easy to move. Check the parameter settings for overspeed (parameter 21), speed governor PID (6100 ... 62XX) and speed depending fuel limitation (6700 ff.) and modify, if necessary. Refer to manual “Basic information 2000”. Finally, press the Error Reset button.

**Pickup error** of both speed pickups, while the engine was running. Check the connectors and wiring, clean pickup surface and re-adjust distance to flywheel (1,5 turns = 2 ... 2,5 mm). Finally, press the Error Reset button.

**Feedback error** of the StG 40 actuator. Check connector and wiring, first. Use *DcDesk 2000* to check the actual feedback value (3950 *Feedback*) and compare this to the reference values (1950, 1951) and error limits (1952, 1953). Remove linkage and perform automatic actuator adjustment. Replace actuator, if error cannot be fixed.

5: **Low oil pressure shutdown** has occurred. It will self-reset, when the engine is restarted.

First, check the lube oil system and monitor the pressure in low idle. If that is o.k., check the 10 bar pressure sensor connector and wiring. Signal must be 4 mA while engine is stopped. Fix wiring or replace sensor, if necessary.

6: Refer to 5. In addition, the Error Reset button must be pressed.

## 11.2 Error Memory

The Heinzmann governor has two error memories. They are available with *DcDesk 2000* communication program. Please, refer to Heinzmann Manual “Basic information 2000”, chapter 14 “Error handling”.

The **Current Errors** show errors being active and waiting for reset.

Errors with emergency stop effect are:

3001 <i>ErrPickUp1</i>	=	1	(if speed pickup 2 has failed as well)
3002 <i>ErrPickUp2</i>	=	1	(both, 3001 and 3002 are = 1 at emergency stop)
3004 <i>ErrOverSpeed</i>	=	1	(overspeed shutdown)
3010 <i>ErrOilPressure</i>	=	1	(low oil pressure shutdown)
3031 <i>ErrOilPressEcy</i>	=	1	(both, 3010 and 3031 are = 1 at emergency stop)
3050 <i>ErrFeedback</i>	=	1	(actuator position feedback out of range)

The **Error Memory** gives informations about any errors having occurred during operation.

The stored errors, corresponding to current errors, are:

3101 *SErrPickUp1*

3102 *SErrPickUp2*

3104 *SErrOverSpeed*

3110 *SErrOilPressure*

3131 *SErrOilPressEcy*

3150 *SErrFeedback*

Follow the instructions above (“Action to be taken”) to remove the error’s cause.

Check the system performance in *DcDesk 2000, Graphic, Curve vs. time*. Enter the error parameter number (30XX) together with the following measuring values:

2000 *Speed*

2033 *SpeedSetpSelect*

2300 *ActPos*

2600 *PowerControlSetpoint*

2602 *PowerGovFuelSetpoint*

2701 *FuelLimitMax*

2904 *BoostPressure*

2905 *OilPressure*.

Freeze the display, when the error comes on again, and read all displayed measuring values

These data will disclose the error reason, if it is a HEINZMANN system failure.

### 11.3 Detailed troubleshooting tips

Engine will not start, actuator remains at stop.

- 1) Make sure that *power supply* is on: Check control box indicator lamps (refer to 11.1).
- 2) Check *fuel linkage* (may be blocking) and actuator cable connection (plug loose or lost).
- 3) Open control box cover and check *speed pickup LEDs* no. 2 and 3 in green DC 2-01 control unit during cranking procedure. LEDs must turn off while cranking starts.
- 4) Check *speed pickups* (distance to flywheel, pollution) and cable connection (plug loose or lost). Try to start again.
- 5) *Clear errors*, if green indicator lamp has turned off (press “Clear Errors” button).

6) Connect PC or hand programmer to control box and check start speed settings. Parameter 255 *StartSpeed1* must be set lower than actual engine cranking speed (compare to 2000 *Speed* during cranking).

7) Check actual errors. In case of *Feedback Error* take fuel linkage off and perform automatic actuator adjustment. Make sure, the feedback error limits (1952, 1953) are at least 4000 digits apart from the reference values (1950, 1951).

8) Test the actuator in *positioning mode*. Set 1700 *PositionerSetpoint* = 50 % and activate function by setting 5700 *PositionerOn* = 1. Actuator must move up to 50 %. Turn off positioning mode (5700 = 0).

9) If positioning mode does not work, turn off the governor power supply and check the *cable between actuator and control box*. Refer to 9.2 Connecting diagram. Pay attention to actuator plug terminals B and C (actuator drive supply).

10) Check parameter 5910 *ActuatorOn*. It must be set to 1.

11) In case the governor cannot be made working, *replace actuator*.

Actuator moves up, but engine will not start.

1) Check the *fuel supply system* (filters, pump, pipes).

2) Connect PC to controller and increase the *start fuel setting* for test: 260 *StartFuel1* (example: 60 % or 70 % instead of 50 % actuator travel).

Engine starts but will stop after a short period of time.

1) Check the *oil pressure alarm* lamp at the control box right after start. If it comes on at the shutdown, low oil pressure alarm is the failure reason.

2) Check the *lube oil system*.

3) If the pressure is o.k., the HEINZMANN *oil pressure sensore* may be faulty. Check value 2905 *OilPressure* and 3010, 3030, 3031 Errors. Replace sensor, if necessary.

Engine is running, but will not respond to speed throttles.

1) Check *signals and wiring* of solenoids A, B, C and D. Refer to 9.2 Connecting diagram.

2) Use *DcDesk 2000, Graphic, Overview* to monitor the solenoid status (see fig. 20). Switch notches must change from 0 to 1, values 2033 *SpeedSetpointSelect* and 3350 *Notch* will show speed setpoint and governor throttle reference number.

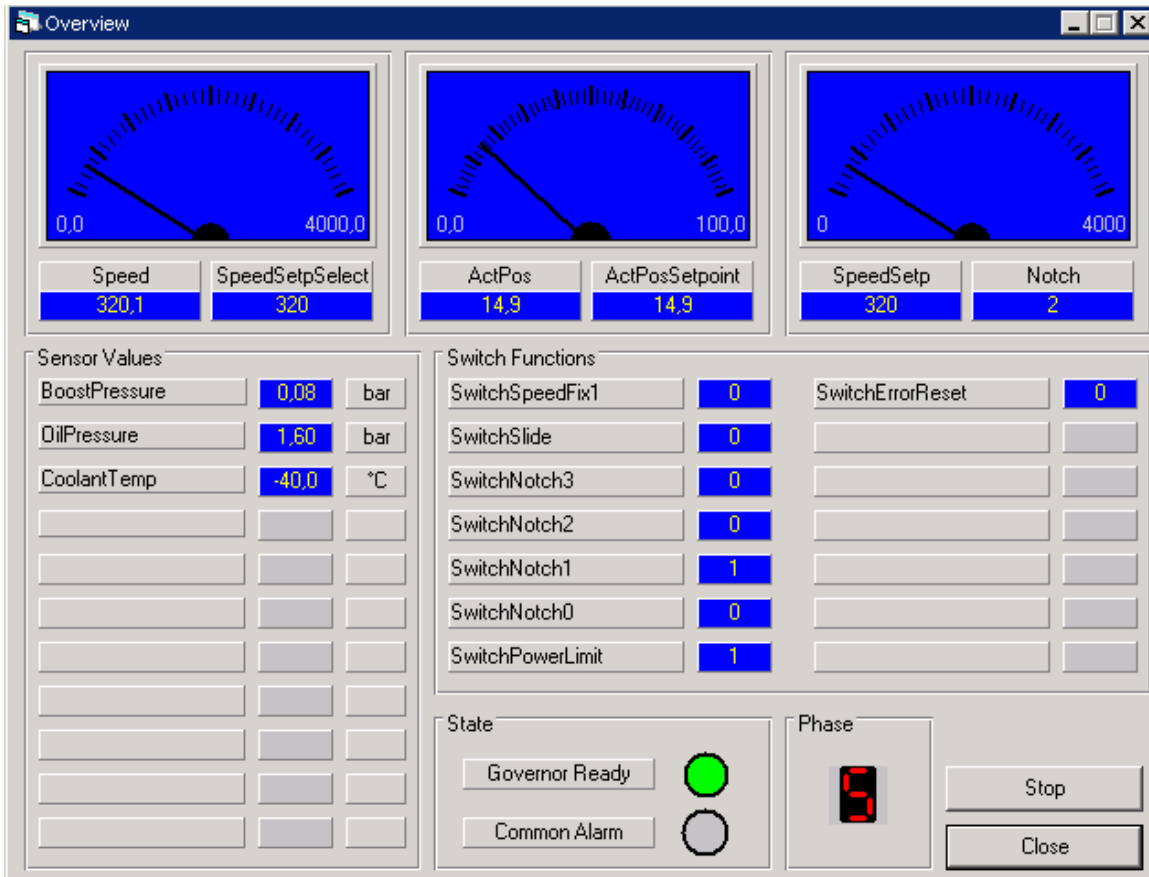
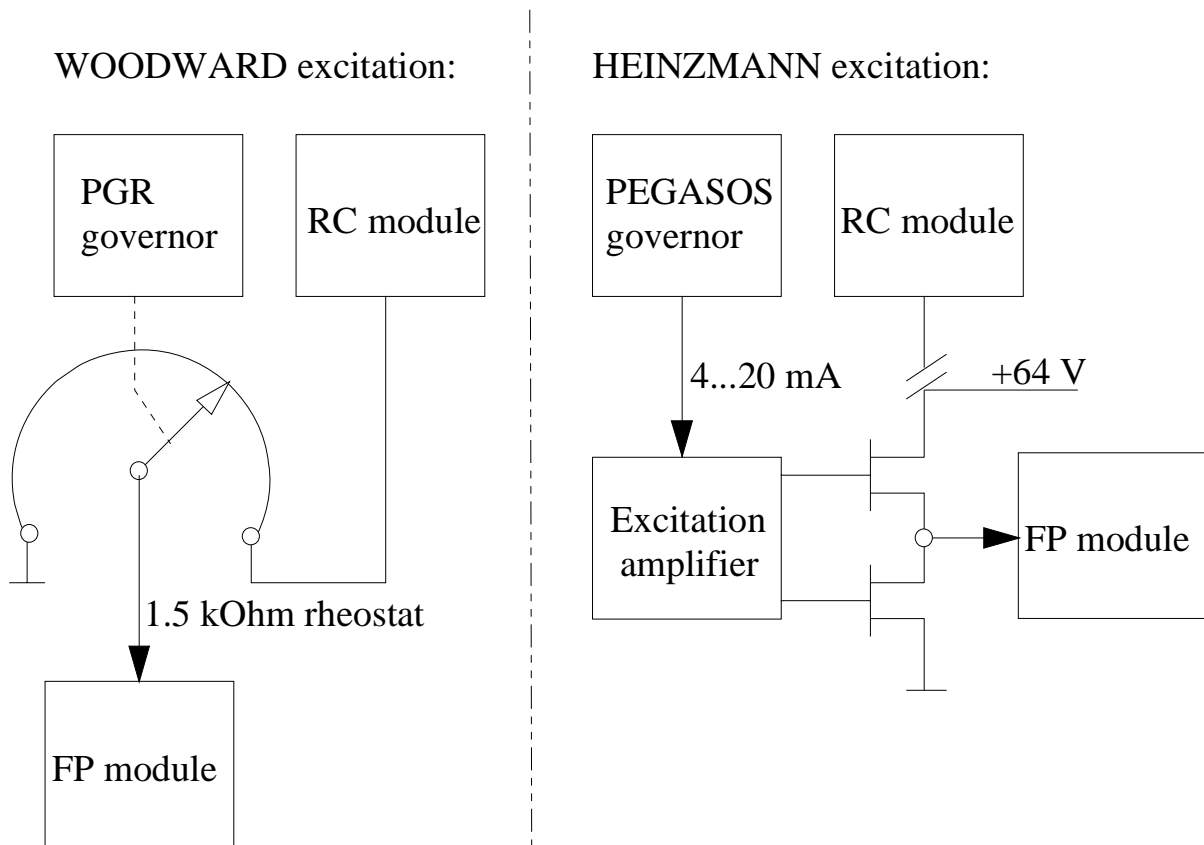

Fig. 20: DcDesk 2000, overview

Engine running, but locomotive will not move.

- 1) Check the excitation voltage signal at locomotive switchboard terminal no. EB2. It should be 8 ... 10 VDC in throttle 1.
- 2) If the voltage is down to 0, check the wiring of HEINZMANN connector no. 1, terminals N, P and H. Refer to 5. System setup, wiring table.
- 3) While running in throttle no. 1, use *DcDesk 2000* to check:
  - 2602 *PowerGovFuelSetpoint* = 18,5 % (example value for throttle 1)
  - 2600 *PowerControlSetpoint*: Should run up towards 100 %, to lift actuator up to 18,5 % (example).
- 4) If signals remain at 0, check ORS input and dynamic brake input (HEINZMANN connector no. 1 terminals M and J). They should not be active (not powered).
- 5) If wiring and signals are o.k., HEINZMANN circuit board X9, excitation amplifier, may be faulty. Refer to the drawing below, in order to check the excitation amplifier function.



**Fig. 21: Excitation control circuit**

Turn off the engine and switch off the power supply.

Disconnect the supply line from RC module to the HEINZMANN excitation amplifier, locomotive switchboard terminal EA2.

Connect the excitation amplifier (terminal P1) to positive 64 VDC power supply voltage for test.

Go to *DcDesk 2000, Governor / Adjustment / Analogue Outputs: Current Output 1: 2600 PowerControlSetpoint*. Activate "Test output".

Set percentage as follows: minimum value (0 %), maximum value (100 %) and 50 %.

Connect a DC voltmeter to excitation amplifier board, terminals 1, 2 (input) and then to 6, 7 (output). Measuring values must be approximately as shown in table:

Test value	Input voltage (1, 2)	Output voltage (6, 7)
0 %	0.88 V (~ 4 mA)	0 V
100 %	4.40 V (~ 20 mA)	64 V (max. voltage)
50 %	2.64 V (~ 12 mA)	32 V

Replace excitation amplifier if necessary. Check test values again.

Switch off test mode. Change wiring back to original after test.

Locomotive is running, but lack of power:

There are two possible reasons for reduced power availability:

1) *Boost pressure depending power limit*: A limit curve “power versus boost pressure” was adjusted during commissioning. If, after a longer running period, the turbine does not supply the former high pressure values anymore, the excitation signal is reduced automatically.

Test: Use *DcDesk 2000* to switch off the boost pressure depending power limit function:

Set 4660 *PowerFuelBoostLimitOn* = 0 and check the power again.

2) *Actuator feedback voltage drift*: After a longer period (a few months), the feedback voltage range may have drifted due to high temperatures and vibrations. Indication would be a increased reading of idle fuel position (2300 *ActPos* in throttle 0):

Example – original value was 14 %, now it is 17 % (engine must be warmed up!)

Take off the fuel linkage and repeat the automatic actuator adjustment. Compare the new reference values (1950, 1951) to the original ones. If the new values are higher, the problem was feedback drift and is solved, now. Make sure, the error limits (1952, 1953) are set about 4000 digits apart from the new reference values.

Locomotive has sufficient power, but power is unstable.

Power being *instable in one throttle* only:

1) Use *DcDesk 2000 / Graphic / Excitation control PID map*. Press Edit and Start, set the critical throttle/power and read the Power PID correction value (in %). Reduce the value for test (say 120 % instead of 140 %), send data and check performance.

2) Use *DcDesk 2000 / Graphic / Curve / Speed values for speed stage switches*. Press Edit and start, set the critical throttle/power and change the actual value for 10 or 20 rpm (upwards or downwards), send data. Find a stable operating point, as close as possible to the original one.

Power being *instable in several throttles*:

This may be effected by a wiring problem like:

Poor terminal contact, lost screen connection, loose Cannon connector, damaged cable isolation, or lube oil inside a speed pickup or actuator connector.

**If the problem cannot be located or fixed, contact one of the following companies:**

**1. Pear Danesh Co., Tehran.**

**2. HEINZMANN GmbH & Co. KG Germany.**



**Heinzmann GmbH & Co. KG**

**Engine & Turbine Controls**

Am Haselbach 1  
D-79677 Schönau (Schwarzwald)  
Germany

Phone +49 7673 8208-0

Fax +49 7673 8208-188

E-mail [info@heinzmann.com](mailto:info@heinzmann.com)

[www.heinzmann.com](http://www.heinzmann.com)