



Heinzmann GmbH & Co. KG
Engine & Turbine Controls

Am Haselbach 1
D-79677 Schönau (Schwarzwald)
Germany





Phone +49 7673 8208-0
Fax +49 7673 8208-188
E-mail info@heinzmann.com
www.heinzmann.com



V.A.T. No.: DE145551926

HEINZMANN[®]
Engine & Turbine Controls

MODBUS

Operating Instructions

 Warning	<p>Read this entire manual and all other publications appertaining to the work to be performed before installing, operating or servicing your equipment.</p> <p>Practice all plant and safety instructions and precautions.</p>
 Danger	<p>Failure to follow instructions may result in personal injury and/or damage to property.</p> <p>HEINZMANN will refuse all liability for injury or damage which results from not following instructions.</p>
 Attention! High Voltage  Danger	<p>Please note before commissioning the installation:</p> <p>Before starting to install any equipment, the installation must have been switched dead.</p> <p>Be sure to use cable shieldings and power supply connections meeting the requirements of the <i>European Directive Concerning EMI</i>.</p> <p>Check the functionality of the existing protection and monitoring systems.</p>
 Danger	<p>To prevent damages to the equipment and personal injuries, it is imperative that the following monitoring and protection systems be installed:</p> <p>Overspeed protection acting independently of the speed governor</p> <p>Overtemperature protection</p> <p>HEINZMANN will refuse all liability for damage which results from missing or insufficiently working overspeed protection.</p> <p>Generator installations will in addition require:</p> <p>Overcurrent protection</p> <p>Protection against faulty synchronization due to excessive frequency, voltage or phase differences</p> <p>Reverse power protection</p>
	<p>Overspeeding can be caused by:</p> <p>Failure of the voltage supply</p> <p>Failure of the actuator, the control unit or of any accessory device</p> <p>Sluggish and blocking linkage</p>

 <p>Warning</p>	<p>Electronically controlled injection (MVC) will in addition require to observe the following:</p> <p>With Common Rail systems, a separate mechanical flow limiter must be provided for every injector pipe.</p> <p>With Pump-Pipe-Nozzle (PPN) and Pump Nozzle (PNE) systems fuel release may be enabled only by the movement of control piston of the solenoid valve. This is to inhibit fuel from being delivered to the injection nozzle in case of seizure of the control piston.</p>
 <p>Warning</p>	<p>The examples, data and any other information in this manual are intended exclusively as instruction aids and should not be used in any particular application without independent testing and verification by the person making the application.</p>
 <p>Danger</p>	<p>Independent testing and verification are especially important in any application where malfunction might result in personal injury or damage to property.</p>
	<p>HEINZMANN make no warranties, express or implied, that the examples, data, or other information in this volume are free of error, that they are consistent with industry standards, or that they will meet the requirements for any particular application.</p>
	<p>HEINZMANN expressly disclaim the implied warranties of merchantability and of fitness for any particular purpose, even if HEINZMANN have been advised of a particular purpose and even if a particular purpose is indicated in the manual.</p>
	<p>HEINZMANN also disclaim all liability for direct, indirect, incidental or consequential damages that result from any use of the examples, data, or other information contained in this manual.</p>
	<p>HEINZMANN make no warranties for the conception and engineering of the technical installation as a whole. This is the responsibility of the user and of his planning staff and specialists. It is also their responsibility to verify whether the performance features of our devices will meet the intended purposes. The user is also responsible for correct commissioning of the whole installation.</p>

Version Information

Version	Description of Revision	Date	By
02-05	created	30.11.04	DeM
	Supplemented by chapter 3 Installation	03.02.05	ShD
11-07	Chapter 3.3 RS485-Two-Wire-System corrected	19.11.07	ShD
	Front page and page header updated, chapter Order Specifications for Manuals, appendixes FAX Replay and Subsidiaries deleted and minor changes	20.11.07	DeM

Table of Contents

	Page
1 Safety Instructions and Related Symbols.....	1
1.1 Basic Safety Measures for Normal Operation.....	2
1.2 Basic Safety Measures for Servicing and Maintenance	2
1.3 Before Putting an Installation into Service after Maintenance or Repair Works	3
2 Introduction	4
2.1 Message Format of Data Transmission	4
2.2 Example of a Data Transmission.....	5
3 Installation	7
3.1 Bus Topology	7
3.2 Bus Configuration	9
3.3 RS485-Two-Wire-System	9
3.3.1 Bus Cable in RS485-Two-Wire-Systems	11
3.3.2 Derivation Cable in RS485-Two-Wire-Systems	11
3.4 RS485-Four-Wire-System.....	12
3.4.1 Bus cable in RS485-Four-Wire-Systems.....	13
3.4.2 Derivation Cable in RS485-Four-Wire-System.....	13
3.5 RS232 Operation	14
3.6 Slave Participant.....	14
3.7 Master Participant.....	15
3.8 Reference Potential.....	15
3.9 Shield.....	16
3.10 Line Termination	18
3.11 Line Polarization	19
3.12 Bus Accessories.....	20
3.13 Device Side Connection Module.....	21
3.14 Connector Plug and Socket	21
4 Module Functions.....	22
4.1 Device Address.....	22
4.2 Supported Function Codes	22
4.3 Supported Exception Codes	23
5 Parameterization and Commissioning	25
5.1 Configuration of Interface	25
5.2 Reading Data	27
5.3 Write Data	29
5.3.1 Assignment of Sensor Values to Sensors	30

5.3.2 Assignment of Binary Values to Switching Functions	31
5.4 Diagnostic Counter	31
6 Technical Data	33
7 Parameter Description	34
7.1 Overview Table	34
7.2 List 1: Parameters	34
7.3 List 2: Measurements	34
7.4 List 3: Functions	36
7.5 List 4: Curves and Maps	36
8 Index of Figures	37
9 Index of Tables	38
10 Index	39
11 Order Specifications for Manuals	40

1 Safety Instructions and Related Symbols

This publication offers specific safety instructions, wherever necessary, to indicate inevitable residual risks when operating the engine. These residual risks imply dangers to

- persons
- product and engine
- environment

The symbols used in this publication are in the first place intended to direct your attention to the safety instructions!



Warning

This symbol is to indicate that there may exist dangers to the engine, to the material and to the environment.



Danger

This symbol is to indicate that there may exist dangers to persons. (Danger to life, personal injury)



**Attention
High
Voltage**

This symbol is to indicate that there exist particular dangers due to electrical high tension. (Mortal danger)



Note

This symbol does not refer to any safety instructions but offers important notes for better understanding the functions that are being discussed. They should at any rate be observed and practiced. The respective text is printed in italics.

The primary issue of these safety instructions is to prevent personal injuries!

Whenever some safety instruction is preceded by a warning triangle labelled “Danger” this is to indicate that it is not possible to definitely exclude the presence of danger to persons, engine, material and/or environment.

If, however, some safety instruction is preceded by the warning triangle labelled “Warning” this will indicate that danger of life or personal injury is not involved.

The symbols used in the text do not supersede the safety instructions. So please do not skip the respective texts but read them thoroughly.

In this publication the Table of Contents is preceded by diverse instructions that among other things serve to ensure safety of operation. It is absolutely mandatory that these notes be read and understood before commissioning or servicing the installation.

1.1 Basic Safety Measures for Normal Operation

- The installation may be operated only by authorized persons who have been duly trained and who are fully acquainted with the operating instructions so that they are capable of working in accordance with these instructions.
- Before turning the installation on please verify and make sure that
 - only authorized personnel are present within the working range of the engine;
 - nobody will be in danger of suffering injuries by starting the engine.
- Before starting the engine always check the installation for visible damages and make sure it is not put into operation unless it is in perfect condition. On detecting any faults please inform your principal immediately!
- Before starting the engine remove any unnecessary material and/or objects from the working range of the installation/engine.
- Before starting the engine check and make sure that all safety devices are working properly.

1.2 Basic Safety Measures for Servicing and Maintenance

- Before performing any maintenance or repair work make sure the working area of the engine has been closed to unauthorized persons. Put on a sign warning that maintenance or repair work is being done.
- Before performing any maintenance or repair work switch off the master switch of the power supply and secure it by a padlock! The key must be kept by the person performing the maintenance and repair works.
- Before performing any maintenance and repair work make sure that all parts of engine to be touched have cooled down to ambient temperature and are dead!
- Replace at once any damaged lines and/or cables!
- Keep the cabinet always closed. Access should be permitted only to authorized persons having a key or tools.
- Never use a water jet to clean cabinets or other casings of electric equipment!

1.3 Before Putting an Installation into Service after Maintenance or Repair Works

- Check on all slackened screw connections to have been retightened.
- Make sure the control linkage has been reattached and all cables have been reconnected.
- Make sure all safety devices of the installation are in perfect order and are working properly.

2 Introduction

Modbus is a serial Master-Slave-protocol. This protocol is open and therefore freely accessible for any user. It provides two transmission modes RTU and ASCII and can be used on RS232 and RS485 or RS422.

For application of the Modbus protocol, the HEINZMANN control units of the THESEUS and HELENOS series must be equipped with an add-on pc board. The HEINZMANN Connection Module uses exclusively RTU mode. Throughout this document, it will therefore be only this mode that is made reference to. As a connection an RS485 or RS422 interface is provided. Hence an additional level converter will be required for connection to an RS232 interface.

Any details concerning the design and operation of the interface relate to the below specifications which can be downloaded from www.modbus.org.

- Hardware reference: Modbus Serial Line Implementation Guide V1.0 - November 2002
- Protocol reference: Modbus Application Protocol V1.1a - June 2004

The following sections give a general overview of the functionality, concept and structure of the Modbus protocol. Experienced Modbus users may skip them and continue with chapter *↑ 3 Installation*.

2.1 Message Format of Data Transmission

Modbus data transmission always consists of a request/reply cycle. Request and reply are always executed sequentially, never simultaneously. To separate the individual messages from each other transmission pauses are required as delimiters.

The following Figure 1 shows a typical request-reply-cycle.

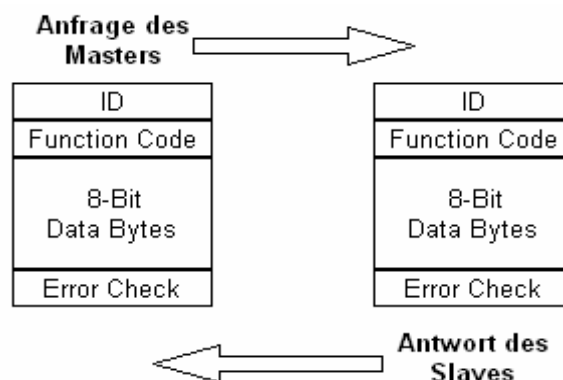

Figure 1: Request-Reply-Cycle

The Modbus protocol defines a simple Protocol Data Unit (PDU) independent of the type of network used and includes a function code indicating by which of the diverse actions the data is to be processed.

As additional information, the Application Data Unit (ADU) includes the participant address (ID) allowing Master and Multi-Slave operation, and a so-called Error Check defined as the check-sum over the characters to be transmitted. The address and the error check are added before and behind the character string as shown in Figure 2 and are transmitted together with it.

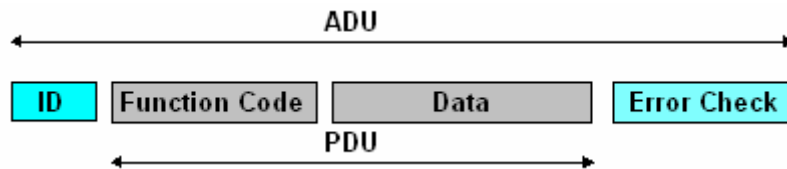

Figure 2: Protocol Frame

In RTU Mode the error check is created by a well-defined procedure (Cyclical Redundancy Check, in short CRC). The error check comprises two bytes.

Besides the error check that is to be evaluated for the totality of a message's characters, it is also possible to set and perform a parity check for each individual byte of a message.

If checking any message for parity or CRC results in an error, processing the message is aborted and no response is returned.

In contrast to errors that are detected by examining the error checks (parity, CRC) and that are not responded to, there may occur errors caused by the user when the specifications for the data to be transmitted exceed the internal address and data ranges of the device or when a function code is not supported. In this case, the request is answered by an exception message indicating the cause by means of an exception code.

To obtain an assessment of the quality of the data exchange, a number of diagnostic counter have been implemented that are assigned to the various causes. These 16-bit counters are incremented on the occurrence of the respective event and can be read out both via Modbus and directly by a HEINZMANN diagnostics tool.

2.2 Example of a Data Transmission

The function code 0x03 “*Read Holding Registers*” is used to explain the sequence of Master request and Slave reply / Slave exception reply by the following tables (Table 1, Table 2 and Table 3). These tables show the formal structure of the transmitted character strings. The last column contains a numeric example in hexadecimal notation.

ID	0 to 247 (decimal)	Slave address	01
Function	1 to 255 (decimal)	Function to be performed	03
Data	Starting Address High	Starting address of data register (high byte)	00
	Starting Address Low	Starting address of data register (low byte)	00
	No. of Registers High	Number of data (high byte)	00
	No. of Registers Low	Number of data (low byte)	01
CRC	CRC Low	Error check CRC (low byte)	84
	CRC High	Error check CRC (high byte)	0A

Table 1: Master Request

ID	0 to 247 (decimal)	Slave address	01
Function	1 to 255 (decimal)	Function to be performed	03
ByteCount	2 to 255 (decimal)	Number of data bytes	02
Data	Register Value High	Data value (high byte)	00
	Register Value Low	Data value (low byte)	00
CRC	CRC Low	Error check CRC (low byte)	B8
	CRC High	Error check CRC (high byte)	44

Table 2: Slave Reply

ID	0 to 247 (decimal)	Slave-Adresse	01
Function	1 to 255 (decimal)	Function to be performed + 0x80	83
Data	Data Byte	Exception code	02
CRC	CRC Low	Error check CRC (low byte)	C0
	CRC High	Error check CRC (high byte)	F1

Table 3: Slave Exception Reply

3 Installation

The installation of a Modbus data bus system requires particular care, especially with regard to electromagnetic compatibility as well as to the data transmission rate to be obtained in dependence on type and length of the conductor. In order to avoid errors in the pre-commissioning phase, the most important points concerning the installation will be discussed in advance. More details will be dealt with in later chapters or are to be found in the Modbus Specification, see section \uparrow 2 Introduction.



Connecting a HEINZMANN control unit to a serial data bus system according to EIA/TIA-485/422 Standard for using the Modbus protocol requires that the control unit be equipped with the Modbus connection module .

3.1 Bus Topology

The bus topology of the Modbus consists of a straight data link cable as shown in Figure 3. Basically, both point-to-point connections and multipoint connections are allowed.

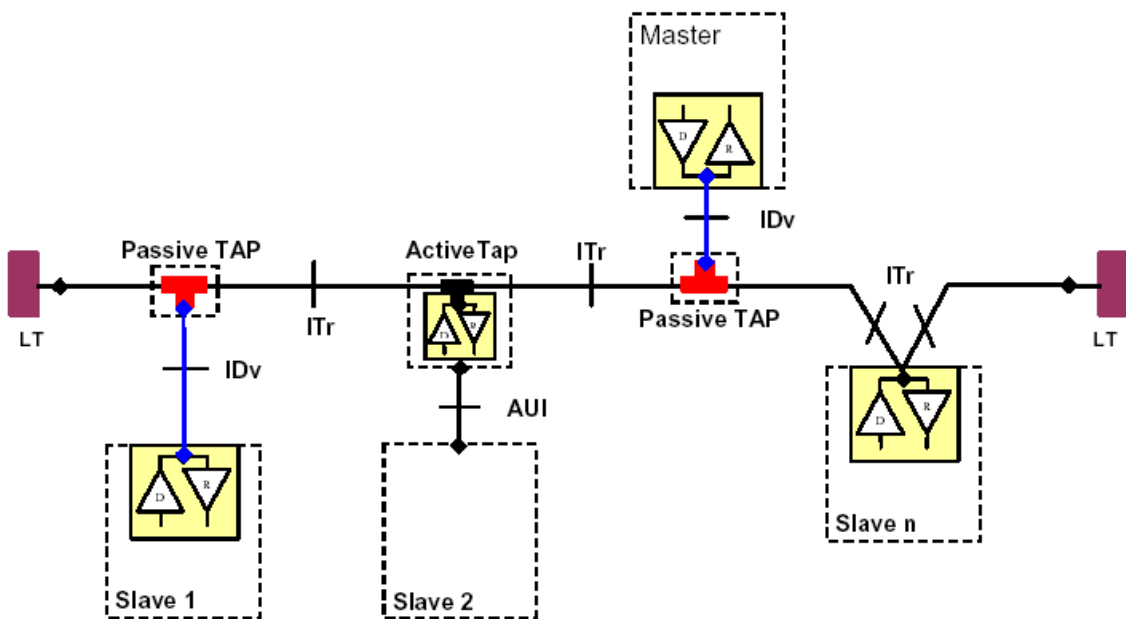

Figure 3: Bus Topology

A remote data cable (trunk) is running across some longer distance from a Modbus Master to one or more Modbus Slaves. Preferably, the individual Slaves are to be connected to the trunk directly by a linear structure (from node to node, Daisy-Chain structure) or by a short derivation cable.

The elements of the bus are:

ITr – Trunk Interface – a bus cable. For different distances, cables with suitable properties must be used, such as characteristic impedance, shield and line construction. The cable lines form a bus of linear structure which is characterized by having two ends. Maximum length is 1,200 m. For more details see the sections [↑ 0 The connectors A and A'](#) pin no. 8 and 9 respectively and B and B' pin no. 4 and 5 respectively have to be shorted to use the two-wire-system with the Modbus connection module for HEINZMANN devices.

Bus Cable in RS485-Two-Wire-System and [↑ 3.4.1 Bus cable in RS485-Four-Wire-Systems](#).

IDv – Derivation Interface – a derivation cable . By the derivation cable all bus signals, the reference potential and the shield must be conducted from the bus to the participant (Slave or Master). A derivation cable may connect several participants, e.g., the devices in a switch cabinet. Derivation cables must not be longer than 20 m. If there is a local tap with more than one derivation cables connected, the cable length must be limited to 40 m divided by the number of derivation cables. For more details see sections [↑ 3.3.2 Derivation Cable in RS485-Two-Wire-Systems](#) and [↑ 3.4.2 Derivation Cable in RS485-Four-Wire-System](#).

Passive TAP – a passive tap. The tap connects the bus cable with the derivation cables, i.e., the data lines, the line for the reference potential and the shield. Possibilities of earthing and termination can be provided within the tap.

Active Tap – a tap having an integrated bus driver. The rest is very much the same as with the passive tap.

AUI – Attachment Unit Interface – a data cable connecting active taps with the participants.

Slave – a participant serving as a Slave device. The maximum number of participants of the bus without repeater is 31. For more details see section [↑ 3.6 Slave Participant](#).

Master - a participant serving as a Master device. Only one Master may be connected to the bus. For more details see section [↑ 3.7 Master Participant](#).

LT – Line Terminator – Bus terminator. At either extremity of the bus a line termination must be provided. For more details see section [↑ 3.10 Line Termination](#).

3.2 Bus Configuration

The Modbus standard provides three communication configurations:

- according to RS485 in a two-wire-system,
- according to RS485 (or RS422) in a four-wire-system and
- according to RS232 (requiring accessory devices for HEINZMANN units).

The first two configurations provide differential data transmission via a balanced twisted pair (or pairs) of conductors. Communication is supported by a reference potential (Common). Due to EMI, the standard Modbus requires using shielded cables. In these operating modes both multiple connections and a point-to-point connection will be allowed.

With RS232 operation, an unbalanced data transmission is basically given using a separate signal line for either direction, i.e. for transmission from Master to Slave and from Slave to Master. This will also require an additional line with the reference potential (Common). RS232 operation is provided only for a point-to-point connection.

As communication equipment the following items will be of importance:

- Slave participant,
- Master participant ,
- Bus cable,
- Derivation cable,
- Reference potential,
- Shield,
- Bus earthing,
- Line termination, and
- Line polarization.

3.3 RS485-Two-Wire-System

In a two-wire-system, bi-directional data are being transmitted, viz. Master-Slave and Slave-Master, by a common balanced twisted pair of conductors. There is, in addition, a separate conductor (e.g. a twisted pair of conductors) for the reference potential (Common). The complete cable must have an external shield.

The 2-wire-system constitutes the configuration most frequently used in practice. The layout of the bus must be about the same as shown in **Figure 4**. In a daisy-chain structure, no derivation cables may be used.

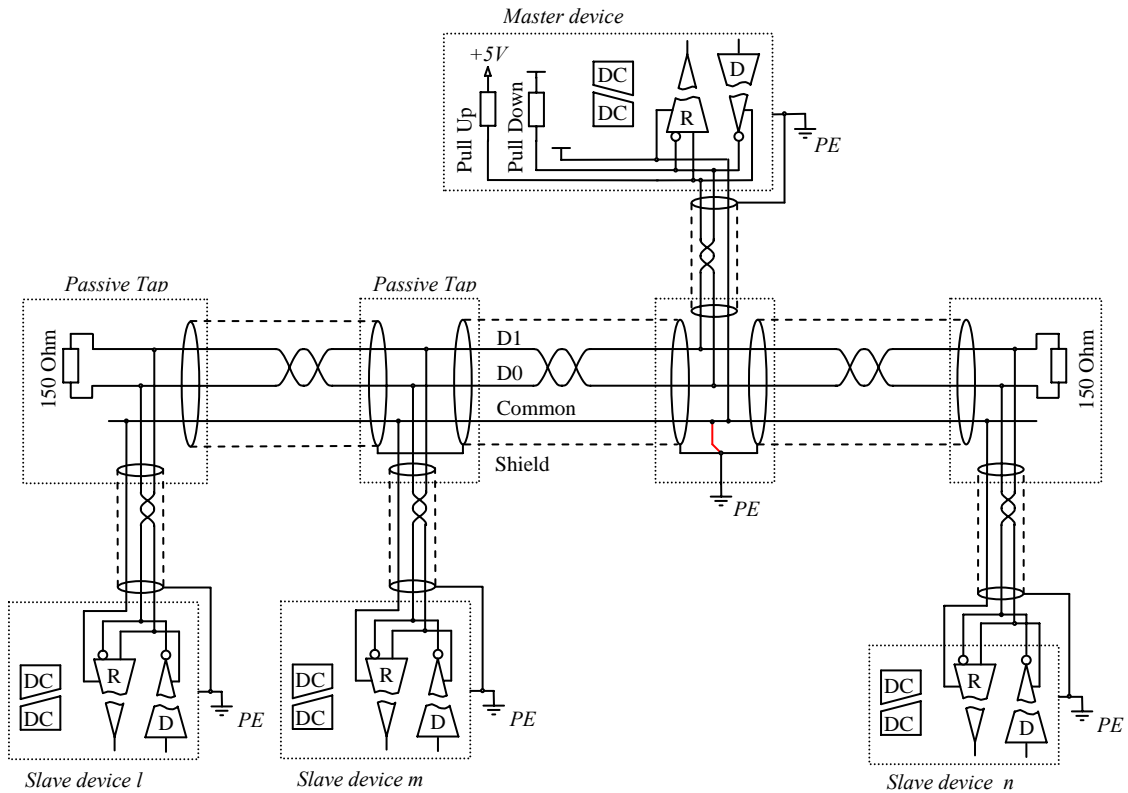

Figure 4: RS485 – Two-Wire-System

The following Table 4 defines the signals as in **Figure 4**.

Designation	for Device	Contact at Participant	EIA/TIA-485 Designation	Description
D1	I/O	yes	B/B'	Transmitter-receiver-terminal 1 (+), voltage V1 (V1 > V0 for binary 1 and OFF-state respectively)
D0	I/O	yes	A/A'	Transmitter-receiver-terminal 0 (-), voltage V0 (V0 > V1 for binary 0 and ON-state respectively)
Common	-	yes	C/C'	Reference potential and optionally as supply potential
Shield	-	yes	-	Cable shield

Table 4: Signal Definition – Two-Wire-System

The connectors A and A' pin no. 8 and 9 respectively and B and B' pin no. 4 and 5 respectively have to be shorted to use the two-wire-system with the Modbus connection module for HEINZMANN devices.

3.3.1 Bus Cable in RS485-Two-Wire-Systems

There exist two variants:

- a cable with one balanced twisted pair of conductors, a separate conductor, and with external shield,
- a cable with two balanced twisted pairs of conductors and with external shield.

The conductor size must generally be chosen for lengths of at least 1,000 m. Thus, for all conductors, including the shield, a gauge of at least AWG 24 must be provided. The characteristic impedance must be no less than 100 Ohms in the frequency range up to 100 kHz (for a baud rate of 19,200).

Basically, also cables with several twisted pairs of conductors can be used such as STP category 5 cables (4 pairs).

3.3.2 Derivation Cable in RS485-Two-Wire-Systems

The derivation cable must consist of:

- at least one balanced twisted pair of conductors for the differential data signal,
- a separate conductor or twisted pair of conductors for the reference potential (Common), and
- an external shield.

For derivations, for instance, the same cable can be used as for the bus.

Generally, also cables with several twisted pairs of conductors can be used.

Every derivation cable connects one or more participants to the bus (by passive taps). Therefore, the derivation cable includes

- the connection to the passive tap (connector, screw terminals, etc.), and
- the connection or connections to the participants (connectors, screw terminals, etc.)

For every participant connection, attention should be paid to the device specific pin and bridge assignments (e.g., 4-wire to 2-wire, see **Figure 4**). The connectors A and A' pin no. 8 and 9 respectively and B and B' pin no. 4 and 5 respectively have to be shorted to use the two-wire-system with the Modbus connection module for HEINZMANN devices.

3.4 RS485-Four-Wire-System

With 4-wire-systems, data transmission in both directions, viz. Master-Slave and Slave-Master, is made by two separate balanced twisted pairs of conductors. There is, in addition, a separate conductor (e.g., a twisted pair of conductors) for the reference potential (Common). The complete cable must have an external shield.

An example of the bus configuration is shown in **Figure 5**. In the daisy-chain structure no derivation cable may be used.

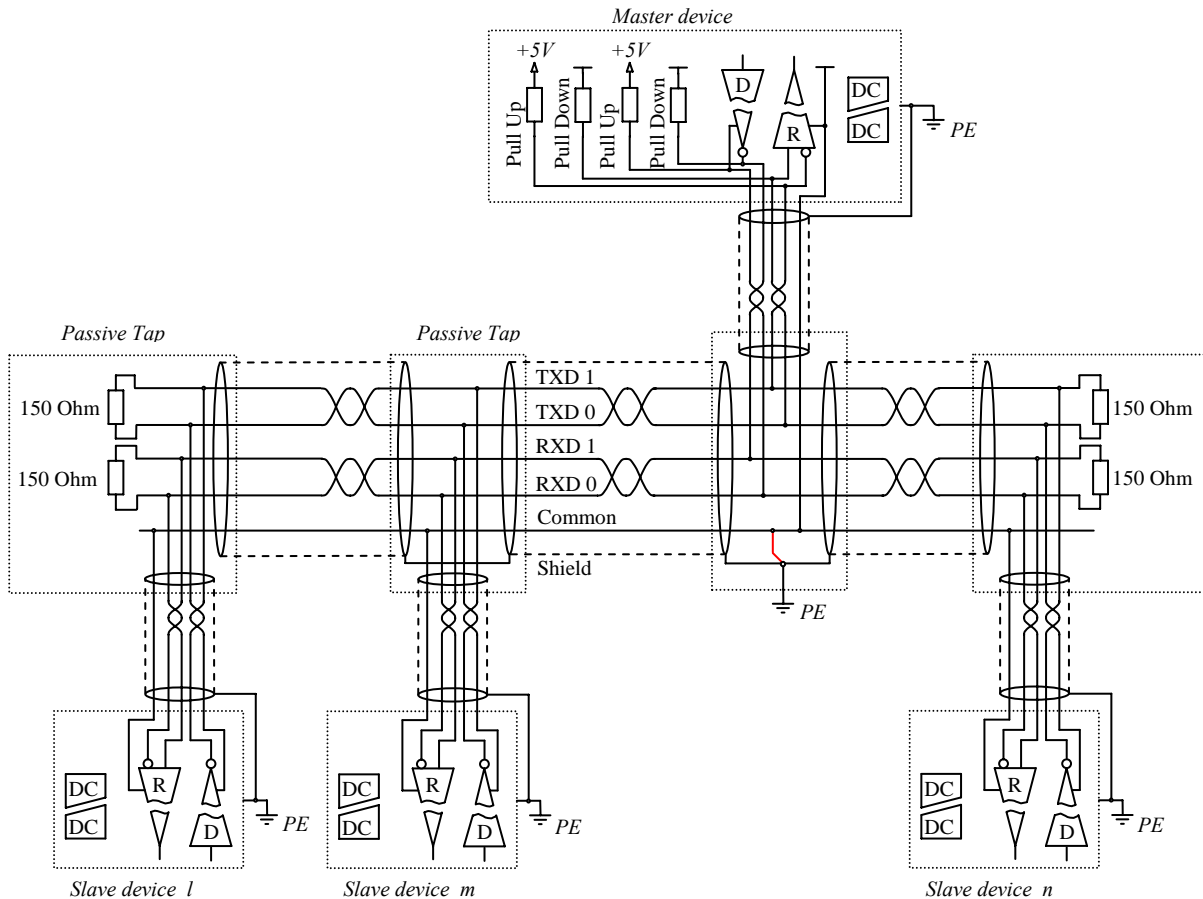

Figure 5: Signal Definition – Four-Wire-System

The following Table 5 defines the signals of **Figure 5**.

Designation	for Device		Contact at Participant	EIA/TIA-485 Designation		Description
	Master	Slave		Master	Slave	
TXD 1	In	Out	yes	B'	B	Transmitter terminal 1 (+), voltage Vb (Vb > Va for binary 1 and OFF-state respectively)

Designation	for Device		Contact at Participant	EIA/TIA-485 Designation		Description
	Master	Slave		Master	Slave	
TXD 0	In	Out	yes	A'	A	Transmitter terminal 0 (-), voltage V_a ($V_a > V_b$ for binary 0 and ON- state respectively)
RXD 1	Out	In	yes	B	B'	Receiver terminal 1 (+), voltage $V_{b'}$ ($V_{b'} > V_{a'}$ for binary 1 and OFF-state respectively)
RXD 0	Out	In	yes	A	A'	Receiver terminal 0 (-), voltage $V_{a'}$ ($V_{a'} > V_{b'}$ for binary 0 and ON- state respectively)
Common	-	-	yes	C/C'	C/C'	Reference potential, optionally serving as supply potential
Shield	-	-	yes	-	-	Cable shield

Table 5: Signal Definition – Four-Wire-System

3.4.1 Bus cable in RS485-Four-Wire-Systems

There exist two variants:

- a cable with two balanced twisted pairs of conductors, a separate conductor and external shield,
- a cable with three balanced twisted pairs of conductors and with external shield.

The conductor size must generally be chosen for lengths of at least 1,000 m. Thus, for all conductors including the shield a gauge of at least AWG 24 must be provided. The characteristic impedance must be no less than 100 Ohms in the frequency range up to 100 kHz (with a baud rate of 19,200).

Basically, also cables with several twisted pairs of conductors may be used such as STP category 5 cables (4 pairs).

3.4.2 Derivation Cable in RS485-Four-Wire-System

The derivation cable must have:

- at least two balanced twisted pairs of conductors for the differential data signal,

- a separate conductor or twisted pair of conductors for the reference potential (Common), and
- an external shield.

For the derivation, for instance, the same cable can be used as for the bus.

Generally, also cables with several twisted pairs of conductors can be used.

Every derivation cable connects one or more participants to the bus (by passive taps). Therefore, the derivation cable includes

- the connection to the passive tap (connector, screw terminals, etc.), and
- the connection and connections to the participants (connectors, screw terminals, etc.) respectively.

For every participant connection, particular attention should be paid the device specific pin assignments.

3.5 RS232 Operation

With RS232 operation, an unbalanced data transmission is basically given using a separate signal line for either direction, i.e. for transmission from Master to Slave and from Slave to Master. This will also require an additional line with the reference potential (Common).

In RS232 operation, the Modbus standard is characterized by the following peculiarities:

- RS232 operation is only provided for point-to-point connections.
- Only a shielded cable may be used as a bus line
- Capacitance between the signal line and the Common line may not exceed 2,500 pF. This implies that the length of the bus line will be limited.
- Neither termination nor polarization of the bus.

The Slave devices by HEINZMANN support RS485 in two-wire and four-wire operation. Applications in RS232 operation will require additional RS232-RS485 interface adapters.

3.6 Slave Participant

The maximum number of devices to be connected to a bus without repeater is up to 31 Slave devices plus one Master device.

All Slave participants must support:

- the 2-wire or 4-wire RS485 standard for two-wire-systems, and
- the 4-wire RS485 standard for four-wire-systems

Every participant must have a potential separation. By this, an electrically isolated communication is established offering these advantages:

- it is suitable for relatively long distances (up to 1,200 m), especially for industrial applications,
- it provides increased immunity against electromagnetic noise, and
- it inhibits larger currents from flowing in case of magnetic disturbances and different earthing potentials.

3.7 Master Participant

By principle, only one Master participant is allowed on the bus. It must support:

- the 2-wire or 4-wire RS485 standard for two-wire-systems, and
- the 4-wire RS485 standard for four-wire-systems

It must also have a potential isolation. Normally, the Master device implements a bus polarization, see also section [↑ 3.11 Line Polarization](#).

3.8 Reference Potential

By means of a separate line all bus participants are pulled onto a common reference potential.

The Modbus standard requires this line to be connected with the protective earthing conductor (PE – Protective Earth) preferably on the Master or on its tap. There is only one single earthing point allowed. This rule is observed by the examples in **Figure 4**, **Figure 5**, **Figure 7** and **Figure 8**.



Although symmetric data transmission as compared with RS232 (asymmetric transmission) shows a relatively greater immunity against interferences and the signal level is to be directly recognized at the data lines, communication is additionally supported by the reference potential (Common).

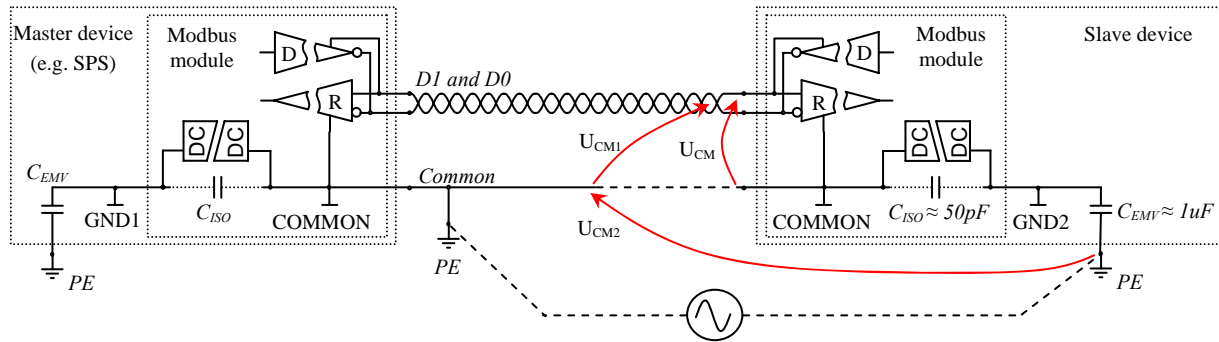

U_{CM1} – Common mode voltage from transmitter with interference induced among the conductors within the bus cable.

U_{CM2} – Interference induced between Common line and protective earthing conductor.

Figure 6: Reference Potential



Note

The indicated common mode voltage U_{CM} must not exceed the level of $-7/+12\text{ V}$ (specific working range). The reference potential (Common) is to be connected to all participants. Then $U_{CM} = U_{CM1}$ will hold for interferences.

3.9 Shield

The Modbus standard requires a shielded cable.

According to this standard, the shield of every cable must be connected at one end to the protective earthing conductor (PE). The shield of any cable is to be connected either to the shield of the other cable or at one of its extremities to protective earthing. The admissible variants are shown in **Figure 4**, **Figure 5**, **Figure 7** and **Figure 8**.

According to our recommendations, the optimum shield configuration will be best as follows:

- A common shield for the bus cables. The only earthing point must preferably be located on the Master or its tap.
- A separate shield for the derivation cables. The only earthing point must be located in the participant's cubicle.

These rules are observed by the examples in **Figure 4**, **Figure 5** and **Figure 8**.

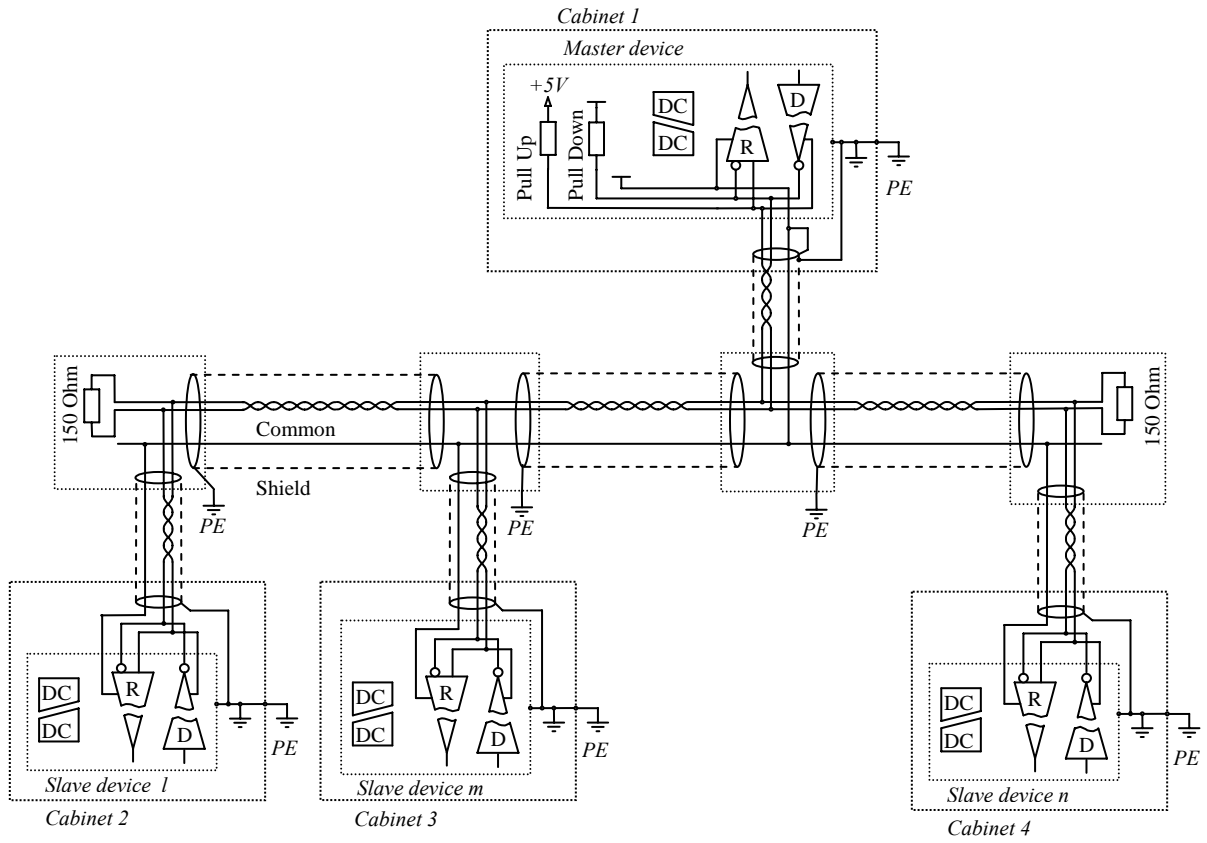

Figure 7: Reference Potential and Shield

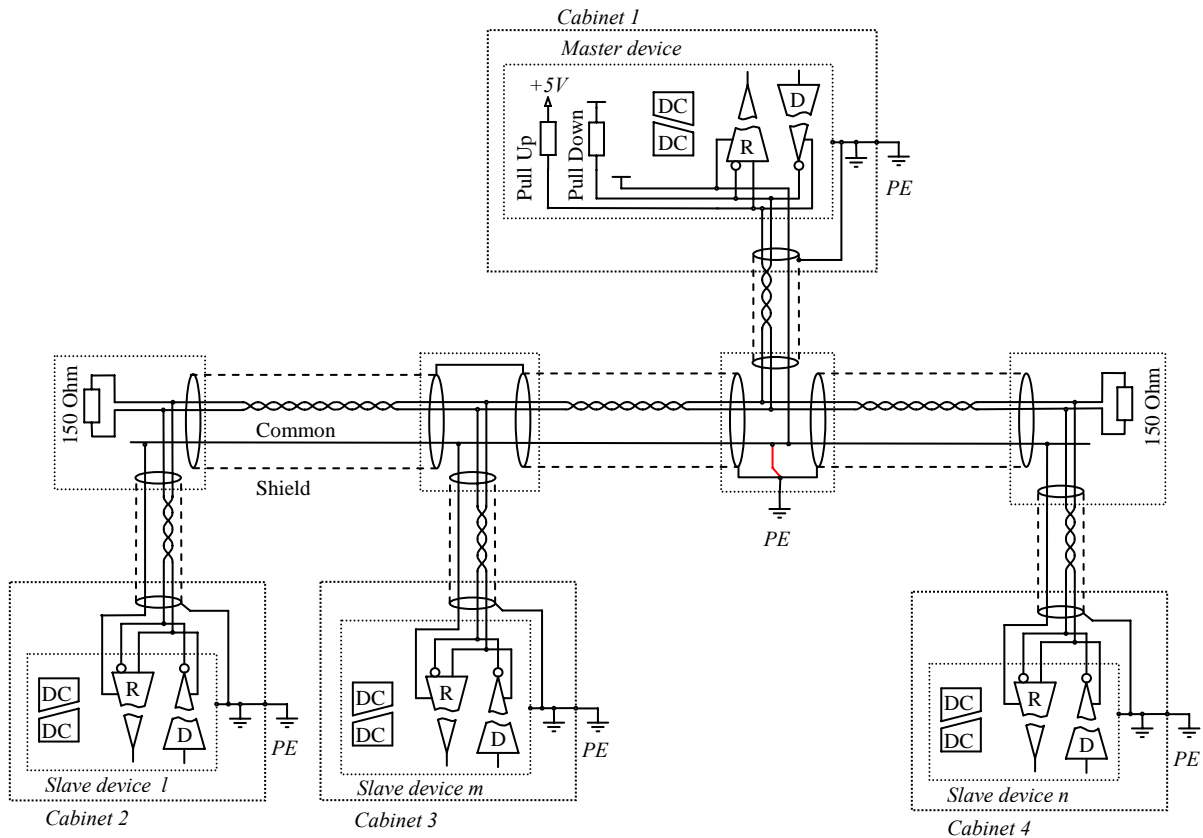

Figure 8: Reference Potential and Shield

The external shield serves as an electrostatic and electromagnetic shield and must not be used as a conductor for the reference potential. The shield must not have a second electric connection to the earthing bus or to the casing.

3.10 Line Termination

Termination of the data line is a measure recommended according to Modbus standard.

In order to obtain optimum transmission quality and/or signal quality, particularly over long distances, the data line is to have a termination as a twisted data conductor pair at both extremities according to **Figure 9**. For this, termination load must correspond to the characteristic impedance of the data line.

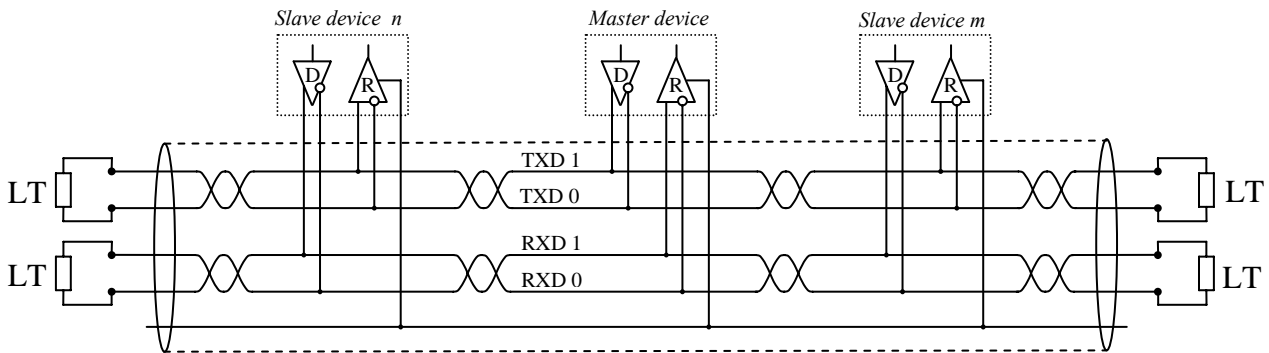

Figure 9: Line Termination in Four-Wire-System

The Modbus standard permits two quasi optimum termination methods:

- AC termination – on either end a serial RC element with capacitor: 1 nF, 10 V minimum and with resistor 120 Ohms, 0.25 W.
Advantage: – maximum signal level up to 5 Vpp.
Disadvantage: – poor reflection behaviour.
- DC termination – on either end a resistor 150 Ohm, 0.5 W.
Advantage: – good reflection behaviour.
Disadvantage: – smaller signal level (e.g., silent state of about 0.27 Vpp).

Preferably, DC termination should be chosen. It is depicted both in **Figure 4** and **Figure 5**.

Termination can be implemented:

- at the bus end in the device connection in the daisy-chain structure, for this see also section [↑ 3.1 Bus Topology](#).
- at the bus end in the participant in the daisy-chain structure if this possibility is provided in the participant,
- in the passive tap at the bus end (see **Figure 4** and **Figure 5**) or
- in the active tap at the bus end.

The termination must not be installed in the derivation cable .

3.11 Line Polarization

A remote data cable needs a polarization for each pair of data conductors which is to be implemented preferably in the Master device or in its tap. Consequently, there is no need for polarization in the Slave devices.

Polarization is to be built using the following components:

- Pull-up resistors that are to be connected against 5 V DC and to signal + (TXD1, RXD1 or D1), and

- Pull down resistors that are to be connected against the reference potential (Common) and to signal + (TXD1, RXD1 or D1).

For all polarization resistors identical values should be chosen that may range from 450 Ohms to 650 Ohms. Polarization requires a 5 V DC supply. A detailed configuration of the polarization is depicted in **Figure 10** and outlined in **Figure 4** and **Figure 5**.

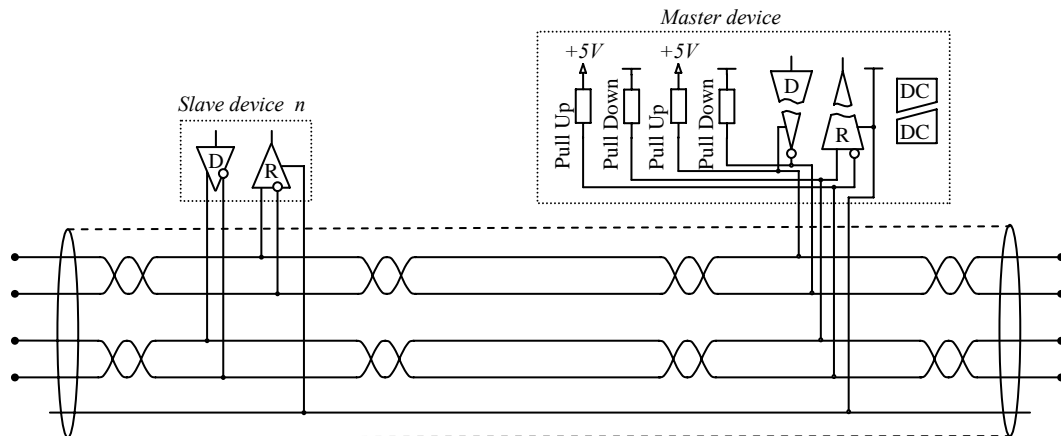

Figure 10: Line Polarization in a Four-Wire-System

If the polarization is implemented in the active/passive tap of the Master device the tap must be supplied 5 V DC either from the Master device or from an electrically separated source.



Note

Line polarization serves to set the OFF-state, where the OFF-state designates the silent state when there is no transmission from any participant. Actually in silent state, however, a polarization current between 3.6 and 5.1 mA DC must be flowing. With a DC termination by 150 Ohms, this will in silent state cause a differential signal of 0.27 to 0.38 V DC. The maximum polarization current will increase interference immunity.

3.12 Bus Accessories

The taps constitute an important element of the bus. As a passive tap for Modbus every suitable bus tap can be used (e.g., Fieldbus, CAN, Ethernet).

The possibility of termination and polarization is already provided in certain taps, such as

- Schneider-Electric, TSX SCA 64 connection box,
- Schneider-Electric, TSX SCA 50,
- Phoenix Contact, PSM PTK (passive RS-485 T-tap),
- Weidmüller, Fieldbus components.

3.13 Device Side Connection Module

In accordance with the EIA/TIA-485/422 standard, the HEINZMANN connection module is designed as a 4-wire interface with separate transmission and reception lines. Due to this, both connection types as a 2-wire and a 4-wire interface can be used. For 2-wire operation, this can be achieved by simply paralleling two lines RX and TX of identical polarity in the connector .

Electrical isolation between bus connection and control unit is provided. On the communication side, the Slave devices by HEINZMANN have no contacting between the reference potential and protective earthing (PE) nor between the case of the connection and protecting earthing (PE).



Danger

For reasons of safety, any direct contacts between humans and the communication lines, the shield and the reference potential should be avoided.

3.14 Connector Plug and Socket

The device side connector socket is a:

- 9 pole Sub-D female connector.

The bus or cable side coupler is a:

- 9 pole Sub-D male connector.

Regarding the specifications concerning the pin assignment of the connectors see section [↑ 6 Technical Data](#).

4 Module Functions

The HEINZMANN control unit is always defined as a Slave and by request from the connected Master can be made to execute a data transfer as determined by the function code . In accordance with the function code, the reply following this request may consist of a read-out of data, an acknowledgement of data received, an exception response or no response.

4.1 Device Address

The device addresses of the participants (ID) of the network must be set by the user in the participant device. Every ID may be assigned only once within a bus segment.



Note

In assigning device addresses it is particularly important to ensure that one and the same address is not assigned to several devices. Such a failure may result in abnormal bus performance so that the Master will not be able to communicate with all Slaves connected to the bus.



Note

Broadcast in Multi-Slave operation or in transmission only mode: Requests under Slave address 0 are accepted by the HEINZMANN control unit but will be without any function! The reaction of the control unit will be no response.

4.2 Supported Function Codes

The following Table 6 lists all supported functions from the Modbus function stock together with a brief description. Whenever an unknown function code is requested by the Master the corresponding exception response will be returned.

Function Code	Function Designation	Brief Description
0x03	<i>Read Holding Register</i>	Read access to one or more data words, for transmission of parameter values or measurements of the control unit
0x06	<i>Write Single Register</i>	Write access to some data word to be further processed by the control unit as a binary value or sensor value
0x08	<i>Diagnostics</i>	Diagnostic function, e.g., reading out the diagnostics counters
0x10	<i>Write Multiple Register</i>	Write access to one or more data words to be further processed by the control unit as a binary value or sensor value

Table 6: Function Codes

The diagnostics function is confined to the sub-function codes that are specified in Table 7; any other sub-functions are not supported and are rejected through an exception response. The request data field or data word is to be assigned the value 0x0000 except for the sub-function code 0x0000 which supports any length and selectable values of the data words.

This functionality serves for diagnosing the communication result and allows to individually or globally read out and reset the counter states that are being incremented with regard to success, error of communication, etc.

Sub-function code	Designation	Brief Description
0x0000	<i>Return Query Data</i>	Request is echoed back
0x0002	<i>Return Diagnostics Register</i>	The data of the sub-functions codes 0x0B to 0x12 are returned in this order
0x000A	<i>Clear Counters and Diagnostic Registers</i>	The counter states of the sub-function codes 0x0B to 0x12 are reset to zero
0x000B	<i>Return Bus Message Count</i>	Quantity of valid messages received is returned
0x000C	<i>Return Bus Communication Error Count</i>	Quantity of errors encountered in receiving messages is returned
0x000D	<i>Return Bus Exception Error Count</i>	Quantity of transmitted exception responses is returned
0x000E	<i>Return Slave Message Count</i>	Quantity of transmitted messages is returned
0x000F	<i>Return Slave No Response Count</i>	Quantity of received messages requiring no response is returned
0x0010	<i>Return Slave NAK Count</i>	Zero is returned
0x0011	<i>Return Slave Busy Count</i>	Zero is returned
0x0012	<i>Return Bus Character Overrun Count</i>	Quantity of messages is returned that due to a character overrun condition were not correctly received

Table 7: Sub-Functions of the Diagnostic Function

4.3 Supported Exception Codes

The possible exception codes that may be contained in an exception response derive from the function codes that are supported. An exception response is returned as a reaction to any request from the Master when the specifications concerning the data to be transmitted

exceed the device's internal address and data ranges or when a function code is not supported. Table 8 offers a list of the supported exception codes of a HEINZMANN control unit.

Exception Code	Designation	Brief Description
0x01	<i>Illegal Function</i>	Function code is not supported
0x02	<i>Illegal Data Address</i>	Data address exceeds the internal data range as provided by the device
0x03	<i>Illegal Data Value</i>	Quantity of data exceeds the internal data range as provided by the device

Table 8: Exception Codes

5 Parameterization and Commissioning

Parameterization of the module is to be performed exclusively by means of the software of the HEINZMANN basis device, which will require either DcDesk 2000 as a Windows® programme for visualizing and configuring the input and output data of digital HEINZMANN control devices, or the Hand Programmer HP-03-03 as a diagnostics tool. For more details, please refer to

- *Operation Manual Communication Programme DcDesk 2000, Manual No. DG 00 003–e,*
- *Operating Instructions Hand Programmer HP-03-03, Manual No. DG 04 002-e,*
- *PRIAMOS / HELENOS Basic Information 2000 for Digital Governors Level 6, Manual No. DG 00 001-e and*
- *THESEUS Control Systems for Electronically Controlled Generator Sets in Isolated and Mains Parallel Operation, Manual No. DG 97 002-e.*

5.1 Configuration of Interface

The configuration of the interface requires parameterizing the baud rate used, the transmission type and the device address within the bus system. The transmission type includes specifications concerning the parity bit and the number of stop bits. In addition, it is necessary to activate the complete Modbus functionality within the HEINZMANN control device. To do so, the user will have to preset the following parameters and function parameters:

21800 <i>Modb:Baudrate</i>	Parameter baud rate,
21801 <i>Modb:SlaveID</i>	Specific device address as Slave,
25800 <i>ModbusOn</i>	On/Off switch for Modbus functionality,
25801 <i>Modb:ParityBitOn</i>	Selection transmission type with or without parity bit,
25802 <i>Modb:ParityOddOrEven</i>	Selection of odd or even parity if parity bit is selected
25803 <i>Modb:OneOrTwoStopBit</i>	Selection of one or two stop bits

The measurement

23800 <i>Modb:Baudrate</i>	Indication value baud rate
----------------------------	----------------------------

will indicate whether the device was able to set the baud rate as selected by means of the respective parameter.



Note

Any changes of the parameter 21800 *Modb:Baudrate* or of the function parameters 25800 *ModbusOn*, 25801 *Modb:ParityBitOn*, 25802 *Modb:ParityOddOrEven* and 25803 *Modb:OneOrTwoStopBit* will be effective only after saving the changes and resetting the control unit.

Table 9 gives an overview of the options for setting the transmission types with regard to parity bit and stop bits.

	No parity with one stop bit	No parity with two stop bits	Even parity with one stop bit	Odd parity with one stop bit
25801 <i>Modb:ParityBitOn</i>	0	0	1	1
25802 <i>Modb:ParityOddOrEven</i>	X	X	0	1
25803 <i>Modb:OneOrTwoStopBit</i>	1	0	1	1

Table 9: Setting for Transmission Type

Example of Parameterization:

Modbus functionality is to be activated with the baud rate set to 9600 Baud and the Slave device address to 1. The data transmission type for a character is to be selected as including one bit for even parity and one stop bit. It should be noted that after making modifications to the settings for the baud rate, the activation of the functionality and the transmission type these changes must be saved and the control unit reset.

Number	Parameter	Value	Unit
21800	<i>Modb:Baudrate</i>	9.600	<i>kBaud</i>
21801	<i>Modb:SlaveID</i>	1	
25800	<i>ModbusOn</i>	1	
25801	<i>Modb:ParityBitOn</i>	1	
25802	<i>Modb:ParityOddOrEven</i>	0	
25803	<i>Modb:OneOrTwoStopBit</i>	1	

Indication

23800	<i>Modb:Baudrate</i>	9.600	<i>kBaud</i>
-------	----------------------	-------	--------------

The standard default settings on shipping the device are

Number	Parameter	Value	Unit
21800	<i>Modb:Baudrate</i>	9.600	<i>kBaud</i>
21801	<i>Modb:SlaveID</i>	247	
25800	<i>ModbusOn</i>	1	
25801	<i>Modb:ParityBitOn</i>	1	

25802	<i>Modb:ParityOddOrEven</i>	0
25803	<i>Modb:OneOrTwoStopBit</i>	1

On request, the shipping state can be modified in dependence of customer wishes and project requirements.

5.2 Reading Data

A read access to one or more data words serves for the transmission of parameter values or measurements of the control unit to the Master device on the Modbus. For this purpose, the function code 0x03 “*Read Holding Register*” is to be used, see also section [↑ 4.2 Supported Function Codes](#).

As regards curve parameters, a data array ranging from 29200 to 29299 *Modb:TxParaSet(x)* is available for the user and can be accessed via the function code 0x03. The start address specified in the request message corresponds with the index of the data array which is limited to 100 entries. The quantity of data to be transmitted beginning with this index is given by the number of registers specified in the request message.

The data field is to be assigned the parameter numbers whose measuring or parameter values are to be transmitted. Particular care should be taken to enter the numbers consecutively beginning with the index zero and without gaps. Note that from the first invalid parameter number on all subsequent entries will be ignored. The following parameter numbers are defined as invalid:

- parameter number zero,
- any parameter number unknown to the control unit, or
- any parameter number associated with a parameter whose level is higher than the access level for the Modbus which on principle is limited to four.



Note

By being invariably set to four the access level for the Modbus allows to transmit all measurements and indication values as well as all application specific parameters.

The user is informed about the maximum number of data words that can be read out by the measurement

23810	<i>Modb:NoOfTxParams</i>	Number of valid parameter numbers in the data array.
-------	--------------------------	--

Example of Parameterization:

Speed, oil pressure and oil temperature are to be read out via Modbus. A control unit of the HELENOS series is being used.

Number	Parameter	Value	Unit
29200	<i>Modb:TxParamSet(0)</i>	2000	
29201	<i>Modb:TxParamSet(1)</i>	2905	
29202	<i>Modb:TxParamSet(2)</i>	2909	
29202	<i>Modb:TxParamSet(3)</i>	0	

Indication

23810	<i>Modb:NoOfTxParams</i>	3	
2000	<i>Speed</i>	1500.2	<i>l/min</i>
2905	<i>OilPressure</i>	3.15	<i>bar</i>
2909	<i>OilTemp</i>	-10.2	<i>°C</i>

External Value Ranges

2000	<i>Speed</i>	0.0..4000.0	<i>l/min</i>
2905	<i>OilPressure</i>	0.00..10.00	<i>bar</i>
2909	<i>OilTemp</i>	-100.0..1000.0	<i>°C</i>

The data are transmitted by their external value ranges. As regards the value ranges of the different parameters the user should refer to the publications describing the HEINZMANN control devices or read them out directly from the control unit using one of the HEINZMANN diagnostics tools. To interpret the data words transmitted correctly, account must be taken of the number of decimal places and of whether the value range can also be negative.

In the above example, the data word for speed will be transmitted by the value 15002 as obtained from $1500.2 \cdot 10$ for one decimal place, that for oil pressure by the value 315 as obtained from $3.15 \cdot 100$ for two decimal places, and that for oil temperature by -102 as obtained from $-10.2 \cdot 10$ for one decimal place.

Since speed and oil pressure can assume positive values only, it is but the number of digital places that must be taken into account as powers of ten. Likewise, if oil temperature is interpreted as already signed, it will also be the number of digital places that is to be evaluated as power of ten.

If oil temperature is evaluated as not yet signed the above example will yield a data word having the value 65,434. Any values greater than or equal to 32,768 are to be interpreted as negative values provided the external value range admits of negative values. The correct signed value is obtained as the difference between the data word and 65,536, and as a second step it is but the number of digital places that must be taken into account to calculate the final value.



Note

If in the above example any request should include a start address equal or greater than two or if the quantity of data to be read exceeds two data words, an exception response will be transmitted.

5.3 Write Data

A given data field can be written to by means of the function codes 0x06 “Write Single Register” (single write mode) and 0x10 “Write Multiple Register” (multiple write mode), see also section [↑]4.2 Supported Function Codes. The write access to one or more data words allows to further process received data within the control device as external input quantities.

By standard, the size of the writeable data field is five words. Due to definition, the first word can be used for 16 binary switch input values and every subsequent data word for a sensor input value. This configuration is shown in Table 10 and may on request be extended according to customer or application needs.

Data Field			
Index			Type
0	8 Bit (high)	8 Bit (low)	switch
1	16 Bit		sensor
2	16 Bit		sensor
3	16 Bit		sensor
4	16 Bit		sensor

Table 10: Write Data

The data received by the control unit can be viewed via these indication values

- 23820 *Modb:RxBinary(0)* to
- 23821 *Modb:RxBinary(1)* Binary values 8 bits wide, and
- 23822 *Modb:RxSensor(0)* to
- 23825 *Modb:RxSensor(3)* Sensor values.

If binary and/or sensor values are to be transmitted to the HEINZMANN control unit in write mode, it should be noted that these values must be transmitted periodically in cyclical order to detect any failures or damages of the data transmission equipment. For this purpose, a time-out is initiated with the first write access whose time limit is to be set by means of the parameter 21820 *Modb:RxTimeOut*. With every valid reception of a request via the functions codes 0x06 or 0x10 the time-out is re-initialized. If the write access fails to occur within the preset reception time limit the error flag 3074 *ErrModbusComm* is set.



Note

If a failure of Modbus communication occurs the standard reactions of the HEINZMANN control units to sensor errors will be applied for the respective sensor value. The binary values are assumed to be zero, and due to this the assigned switching functions are reset.

For further details concerning the parameterization of sensors and switching function, refer to the chapters *Sensors* and *Inputs and Outputs* of the respective Basis Information. In this brochure, it is only the specific extension of the particular functionality required for Modbus that will be dealt with.

5.3.1 Assignment of Sensor Values to Sensors

The assignment of sensor values as inputs to sensors via Modbus is achieved by entering the desired channel numbers, in this case the respective index plus one, in the associated parameters from 900 *Assign...* onward. The selection of the sensor as Modbus sensor value is made by specifying the channel type in the parameters from 4900 *ChanTyp...* onward. For Modbus, it is always the value '6' that is to be specified as channel type.

49xx *ChanTyp...* = 6 Sensor value is being received via Modbus

The transmission of any sensor value from the Master to the HEINZMANN control unit operating as a Slave will on principle be made within the internal value range which is defined as ranging from 0 to 65535.



Note

The scaling of the sensor value from 0% to 100% is equivalent to values from 0 to 65535 being transmitted via Modbus. In the above example this will yield the value 32767 for 50%.

Example of Parameterization:

The power set point is to be received via Modbus as second sensor value. The sensor value is to be updated cyclically every two seconds. A control unit of the THESEUS series is being used.

Number	Parameter	Value	Unit
900	<i>Assign_PowerSetpoint</i>	2	
980	<i>PowerSetpointLow</i>	0.0	%
981	<i>PowerSetpointHigh</i>	100.0	%
4900	<i>ChanType_PowerSetp</i>	6	
21820	<i>Modb:RxTimeOut</i>	2.5	s

Indication

2900	<i>PowerSetpoint</i>	50.0	%
3074	<i>ErrModbusComm</i>	0	
23822	<i>Modb:RxSensor(0)</i>	0.0	%

23803	<i>Modb:ExceptErrCnt</i>	Quantity of exception messages transmitted,
23804	<i>Modb:SlaveMessageCnt</i>	Quantity of messages transmitted,
23805	<i>Modb:SlaveNoRespCnt</i>	Quantity of No response messages,
23806	<i>Modb:BusCharOvrCnt</i>	Quantity of messages not correctly received due to character overrun.

6 Technical Data

Interface:	EIA/TIA-485/422 standard 4-wire interface
Insulation:	electrically separated
Insulation voltage:	1000 Volts _(RMS) , 1 min
Signal voltages against reference potential (Common):	-7 V to +12 V D.C.
Interference immunity (ESD):	to EN 61000-4-2 (intended)
Connector:	D-Sub 9 (male)
Signal assignment:	according to Modbus Specification 4-wire interface

Pin	Signal	EIA/TIA-485/422	Description
8	RXD0	A'	Receiver connection 0
4	RXD1	B'	Receiver connection 1
9	TXD0	A	Transmitter connection 0
5	TXD1	B	Transmitter connection 1
2	VP	---	+5 V DC (depending on version)
1	Common	C/C'	Signal reference potential
Case	---	---	potential free

Table 11: Signal Assignment

Visual error indication:	none
Data transmission:	RTU Mode
Baud rate:	9,600, 19,200 Baud
Parity:	no parity, even or odd parity
Stop bits	one or two
Function codes:	see section ↑ 4.2 Supported Function Codes
Exception codes:	see section ↑ 4.3 Supported Exception Codes

7 Parameter Description

7.1 Overview Table

Parameters		Measurements		Functions		Curves	
		3074	ErrModbusComm				
		3174	SErrModbusComm				
21800	Modb:Baudrate	23800	Modb:Baudrate	25800	ModbusOn		
21801	Modb:SlaveID	23801	Modb:BusMessageCnt	25801	Modb:ParityBitOn		
		23802	Modb:CommErrorCnt	25802	Modb:ParityOddOrEven		
		23803	Modb:ExceptErrCnt	25803	Modb:OneOrTwoStopBit		
		23804	Modb:SlaveMessageCnt				
		23805	Modb:SlaveNoRespCnt				
		23806	Modb:BusCharOvrCnt				
		23810	Modb:NoOfTxParams				
21820	Modb:RxTimeOut	23820	Modb:RxBinary				
		23822	Modb:RxSensor				
						29200	Modb:TxParaSet

7.2 List 1: Parameters

21800 Modb:Baudrate

Level: 4 Modbus
 Range: 9.6..19.2 kBaud Parameter baud rate, modification only effective after
 Page(s): 25 reset

21801 Modb:SlaveID

Level: 4 Modbus
 Range: 1..247 Unique device address as Slave
 Page(s): 25

21820 Modb:RxTimeOut

Level: 4 Modbus
 Range: 0..60 s Reception time limit for requests for writing binary
 Page(s): 29 values or sensor values

7.3 List 2: Measurements

3074 ErrModbusComm

Level: 1 Modbus
 Range: 0..1 Error indication Modbus communication
 Page(s): 29

3174	SErrModbusComm	Level:	1	<u>Modbus</u>
		Range:	0..255 oder 0..1	Error Counter or sentinel for the occurrence of 3074 <i>ErrModbusComm</i>
23800	Modb:Baudrate	Level:	4	<u>Modbus</u>
		Range:	9.6..19.2 kBaud	Indication value for the preset baud rate
		Page(s):	25	
23801	Modb:BusMessageCnt	Level:	4	<u>Modbus</u>
		Range:	0..65535	Quantity of valid received messages
		Page(s):	31	
23802	Modb:CommErrorCnt	Level:	4	<u>Modbus</u>
		Range:	0..65535	Quantity of faulty received messages
		Page(s):	31	
23803	Modb:ExceptErrCnt	Level:	4	<u>Modbus</u>
		Range:	0..65535	Quantity of exception messages transmitted
		Page(s):	32	
23804	Modb:SlaveMessageCnt	Level:	4	<u>Modbus</u>
		Range:	0..65535	Quantity of messages transmitted
		Page(s):	32	
23805	Modb:SlaveNoRespCnt	Level:	4	<u>Modbus</u>
		Range:	0..65535	Quantity of messages received requiring no response
		Page(s):	32	(here: only transmission message from Master)
23806	Modb:BusCharOvrCnt	Level:	4	<u>Modbus</u>
		Range:	0..65535	Quantity of messages not correctly received due to character overrun
		Page(s):	32	
23810	Modb:NoOfTxParams	Level:	4	<u>Modbus</u>
		Range:	0..100	Number of valid parameter numbers entered in the data field for read access
		Page(s):	27	
23820	Modb:RxBinary(x)	Level:	4	<u>Modbus</u>
bis		Range:	00..FF Hex	Binary values for write access
23821		Page(s):	29	
23822	Modb:RxSensor(x)	Level:	4	<u>Modbus</u>
bis		Range:	0..100 %	Sensor values for write access
23825		Page(s):	29	

7.4 List 3: Functions

25800	ModbusOn		
	Level:	4	<u>Modbus</u>
	Range:	0..1	On/Off switch Modbus functionality. Modification will
	Page(s):	25	be effective after reset only
25801	Modb:ParityBitOn		
	Level:	4	<u>Modbus</u>
	Range:	0..1	Selection transmission mode with or without parity bit.
	Page(s):	25	Modification will be effective after reset only
			0 = no parity bit
			1 = with parity bit
25802	Modb:ParityOddOrEven		
	Level:	4	<u>Modbus</u>
	Range:	0..1	Selection odd or even parity with parity bit set.
	Page(s):	25	Modification will be effective after reset only
			0 = even parity
			1 = odd parity
25803	Modb:OneOrTwoStopBit		
	Level:	4	<u>Modbus</u>
	Range:	0..1	Selection one or two stop bits. Modification will be
	Page(s):	25	effective after reset only
			0 = two stop bits
			1 = one stop bit

7.5 List 4: Curves and Maps

29200	Modb:TxParaSet(x)		
bis	Level:	4	<u>Modbus</u>
29299	Range:	0..29999	Data field for read access
	Page(s):	27	Any parameters or measurement numbers must be
			entered whose values will be transmitted on request

8 Index of Figures

Figure 1: Request-Reply-Cycle.....	4
Figure 2: Protocol Frame.....	5
Figure 3: Bus Topology.....	7
Figure 4: RS485 – Two-Wire-System.....	10
Figure 5: Signal Definition – Four-Wire-System.....	12
Figure 6: Reference Potential.....	16
Figure 7: Reference Potential and Shield.....	17
Figure 8: Reference Potential and Shield.....	18
Figure 9: Line Termination in Four-Wire-System.....	19
Figure 10: Line Polarization in a Four-Wire-System.....	20

9 Index of Tables

Table 1: Master Request.....	6
Table 2: Slave Reply	6
Table 3: Slave Exception Reply	6
Table 4: Signal Definition – Two-Wire-System	10
Table 5: Signal Definition – Four-Wire-System	13
Table 6: Function Codes	22
Table 7: Sub-Functions of the Diagnostic Function.....	23
Table 8: Exception Codes	24
Table 9: Setting for Transmission Type.....	26
Table 10: Write Data	29
Table 11: Signal Assignment	33

10 Index

Baud Rate.....	25, 33, 34	Parameterization	25
Binary Value	29, 31, 35	Parity.....	5, 33
Broadcast.....	22	Parity Bit.....	25, 26, 36
Bus Cable.....	8, 9, 16	Participant Address	5
Bus Topology.....	7	Polarization	9, 15, 19, 20
Channel Type	30, 31	Protocol Reference.....	4
Connection Module.....	4, 7, 21	Read Access.....	22, 27, 35, 36
Connector.....	21, 33	Reception Time Limit	29, 34
Data Transmission	4, 33	Reference Potential ...	8, 9, 11, 12, 14, 15, 20, 21, 33
DcDesk 2000.....	25	RTU Mode	4, 5, 33
Derivation Cable	8, 9, 11, 12, 13, 16, 19	Sensor Value	29, 30, 35
Device Address	22, 25, 34	Shield	8, 16, 18
Diagnostic Function	22	Signal Assignment	33
Diagnostics Tool	5, 25, 28	Signal Voltages	33
EIA/TIA-485/422 Standard.....	7, 21, 33	Slave	8, 22
Error Check.....	5	Slave Participant	9, 14
Exception Code	5, 23, 33	Socket	21
Four-Wire-System.....	9, 12, 14, 15	Stop Bits.....	25, 26, 33, 36
Function Code.....	4, 22, 33	Sub-Function Code	23
0x03.....	5, 27	Switching Functions.....	31
0x06.....	29	Tap	8, 11, 14, 15, 16, 19, 20
0x08.....	31	Termination.....	18, 19
0x10.....	29	Two-Wire-System.....	9, 14, 15
Handprogrammer HP-03-03.....	25	Visual Error Indication	33
Hardware Reference.....	4	Write Access	22, 29, 35
Insulation	33		
Insulation Voltage	33		
Interface	25, 33		
RS232.....	4, 9, 15		
RS422.....	4, 9		
RS485.....	4, 9, 14, 15		
Interference Immunity.....	33		
Line Termination	9		
Master	8, 15, 16, 22, 23, 30		
Master Participant	9, 15		
Operating Instructions Modbus			

11 Order Specifications for Manuals

There is no charge for our technical manuals ordered in reasonable quantities.

Order the necessary manuals on our speed governors from your nearest [HEINZMANN location](#).

(Please click on “HEINZMANN location” to see the list of our subsidiaries and agents in the world).

Please include the following information:

- your name,
- the name and address of your company (you can simply include your business card),
- the address where you want the manuals sent (if different from above),
- the number(s) (as on front page bottom right) and title(s) of the desired manual(s),
- or the technical data of your HEINZMANN equipment,
- the quantity you want.

You can directly use the following fax-form for ordering one or several manuals.

Most of the manuals are available as acrobat PDF-files, too. On request they can be send via e-mail.

We solicit comments about the content and the presentation of our publications. Please, send your comments to:

HEINZMANN GmbH & Co. KG

Service Department

Am Haselbach 1

D-79677 Schönau

Germany

Fax Reply

Order for HEINZMANN technical manuals

Fax-Hotline +49 7673 8208 194

Please send me the following manuals:

Quantity	No. of the manual	Title

Please send me your new sales documentation about

() the HEINZMANN Analogue Governors Application:.....

() the HEINZMANN Digital Governors Application:.....

() the HEINZMANN Gas Engine Equipment Application:.....

Company

Contact Person.....

Department

Address..... Country/Code/Town.....

Phone..... Fax

E-Mail.....

Activity.....

Date