



**Heinzmann GmbH & Co. KG**  
**Engine & Turbine Controls**

Am Haselbach 1  
D-79677 Schönau (Schwarzwald)  
Germany

Phone +49 7673 8208-0  
Fax +49 7673 8208-188  
E-mail [info@heinzmann.com](mailto:info@heinzmann.com)  
[www.heinzmann.com](http://www.heinzmann.com)

V.A.T. No.: DE145551926

**HEINZMANN<sup>®</sup>**  
Digital Speed Governors





**Digital Basic System**



**PANDAROS V**

**DG L20.6 - 01 up to - 05**

**DG L40.6 - 01 up to - 05**



 <b>Warning</b>	<p>Read this entire manual and all other publications appertaining to the work to be performed before installing, operating or servicing your equipment. Practice all plant and safety instructions and precautions.</p>
 <b>Danger</b>	<p>Failure to follow instructions may result in personal injury and/or damage to property.</p>
 <b>Danger! High Voltage</b>   <b>Danger</b>	<p><b>Please note before commissioning the installation:</b></p> <p>Before starting to install any equipment, the installation must have been switched dead!</p> <p>Be sure to use cable shieldings and power supply connections meeting the requirements of the <i>European Directive concerning EMI</i>.</p> <p>Check the functionability of the existing protection and monitoring systems.</p>
 <b>Danger</b>	<p><b>To prevent damages to the equipment and personal injuries, it is imperative that the following monitoring and protection systems have been installed:</b></p> <p>Overspeed protection acting independently of the speed governor Overtemperature protection</p> <p><b>Generator installation will in addition require:</b></p> <p>Overcurrent protection Protection against faulty synchronization due to excessive frequency, voltage or phase differences Reverse power protection</p>
	<p><b>Overspeeding can be caused by:</b></p> <p>Failure of the voltage supply Failure of the control unit or of any accessory device Failure of the actuator Sluggish and blocking linkage</p>

 <b>Warning</b>	<p><b>Electronically controlled injection (MVC) will in addition require to observe the following:</b></p> <p>With <b>Common Rail</b> systems a separate mechanical flow limiter must be provided for each injector pipe.</p> <p>With <b>Pump-Pipe-Nozzle (PPN)</b> and <b>Pump Nozzle (PNE)</b> systems fuel release may be enabled only by the movement of control piston of the solenoid valve. This is to inhibit fuel from being delivered to the injection nozzle in case of seizure of the control piston.</p>
 <b>Warning</b>	<p>The examples, data and any other information in this manual are intended exclusively as instruction aids and should not be used in any particular application without independent testing and verification by the person making the application.</p>
 <b>Danger</b>	<p>Independent testing and verification are especially important in any application in which malfunction might result in personal injury or damage to property.</p>
	<p><b>HEINZMANN</b> make no warranties, express or implied, that the examples, data, or other information in this volume are free of error, that they are consistent with industry standards, or that they will meet the requirements for any particular application.</p>
	<p><b>HEINZMANN</b> expressly disclaim the implied warranties of merchantability and of fitness for any particular purpose, even if <b>HEINZMANN</b> have been advised of a particular purpose and even if a particular purpose is indicated in the manual.</p>
	<p><b>HEINZMANN</b> also disclaim all liability for direct, indirect, incidental or consequential damages that result from any use of the examples, data, or other information contained in this manual.</p>
	<p><b>HEINZMANN</b> make no warranties for the conception and engineering of the technical installation as a whole. This is the responsibility of the user and of his planning staff and specialists. It is also their responsibility to verify whether the performance features of our devices will meet the intended purposes. The user is also responsible for correct commissioning of the total installation.</p>

## Contents

	Page
<b>1 Safety Instructions and Related Symbols .....</b>	<b>1</b>
1.1 Basic Safety Measures for Normal Operation.....	2
1.2 Basic Safety Measures for Servicing and Maintenance .....	2
1.3 Before Putting an Installation into Service after Maintenance and Repair Works .....	3
<b>2 General .....</b>	<b>4</b>
<b>3 Functions .....</b>	<b>5</b>
3.1 General Functions.....	5
3.2 Variation specific additional Functions.....	6
3.2.1 Variation DC 6-01 (Standard Generator) .....	6
3.2.2 Variation DC 6-02 (Standard General) .....	6
3.2.3 Variation DC 6-03 (Extended Generator 1) .....	7
3.2.4 Variation DC 6-04 (Extended Generator 2) .....	7
3.2.5 Variation DC 6-05 (Extended General, especially vehicle).....	7
<b>4 Further Informations.....</b>	<b>8</b>
<b>5 Block Diagram.....</b>	<b>9</b>
<b>6 Sensors.....</b>	<b>10</b>
6.1 Overview .....	10
6.2 Magnetic Pickup IA .....	11
6.2.1 Technical Datas .....	11
6.2.2 Installation.....	11
6.2.3 Tooth profile.....	12
6.2.4 Clearance of Magnetic Pickup .....	12
6.2.5 Mounting Measurements.....	13
6.3 Cooling Medium Temperature Sensor TS 01 - 28 - PT 1000 (EDV- No.: 600 00 053 00).....	13
6.4 Pressure Sensors .....	14
6.4.1 Oil Pressure Sensor .....	14
6.4.2 Boost Pressure Sensors .....	15
6.4.2.1 Boost Pressure Sensor with Plug.....	16
6.4.2.2 Boost Pressure Sensor with Housing and Terminal Strip .....	16
<b>7 Setpoint Adjusters.....</b>	<b>18</b>
7.1 Setpoint Potentiometer SW 01 - 1 - b (1 turn) (EDV- No.: 600 00 041 01) .....	18

7.2 Setpoint Potentiometer SW 02 - 10 - b (10- turn) (EDV- No.: 600 00 042 01) .....	18
7.3 Setpoint Value Adjustment by Current Signal .....	19
7.4 Digital Presetting of Setpoint Values .....	19
7.5 Setpoint Value Adjustment by Pedal.....	19
7.6 Pneumatic Setpoint Adjuster .....	19
<b>8 Control Unit DC 6 – 01..05 .....</b>	<b>20</b>
8.1 Specification .....	20
8.1.1 General .....	20
8.1.2 Inputs and Outputs .....	21
8.2 Measurements .....	22
8.3 Mounting .....	24
<b>9 Actuators .....</b>	<b>25</b>
9.1 Design and Mode of Operation .....	25
9.2 Installation .....	25
9.3 Specification .....	27
9.4 Measurements .....	28
<b>10 Electrical Connection .....</b>	<b>30</b>
10.1 Connection for variation DG 6-01 (Standard Generator).....	30
10.2 Connection for variation DG 6-02 (Standard General) .....	31
10.3 Connection for variation DG 6-03 (Extended Generator 1).....	32
10.4 Connection for variation DG 6-04 (Extended Generator 2).....	33
10.5 Connection for variation DG 6-05 (Extended General) .....	34
10.6 Harness .....	35
<b>11 Parametrization Possibilities .....</b>	<b>37</b>
11.1 Parametrization at the Factory .....	37
11.2 Parametrization with the Hand Held Programmer 3 .....	37
11.3 Parametrization with the Keyboard on the Control Unit .....	37
11.4 Parametrization with the PC.....	37
11.5 Parametrization with User Masks.....	38
11.6 Transferring Data Sets .....	38
11.7 Assembly Line End Programming .....	38
<b>12 Starting the Engine - Brief Instructions.....</b>	<b>39</b>
<b>13 Order Information .....</b>	<b>40</b>
<b>14 Order Specifications for Manuals.....</b>	<b>41</b>

## 1 Safety Instructions and Related Symbols

This publication offers wherever necessary practical safety instructions to indicate inevitable residual risks when operating the engine. These residual risks imply dangers to

persons  
product and engine  
environment.

The symbols used in this publication are in the first place intended to direct your attention to the safety instructions!



**Warning**

This symbol is to indicate that there may exist dangers to the engine, to the material and to the environment.



**Danger**

This symbol is to indicate that there may exist dangers to persons. (Danger to life, personal injury).



**Danger!  
High  
Voltage**

This symbol is to indicate that there exist particular danger due to electrical high tension. (Mortal danger).



**Note**

*This symbol does not refer to any safety instructions but offers important notes for better understanding the functions that are being discussed. They should by all means be observed and practiced. The respective text is printed in italics.*

### **The primary issue of these safety instructions is to prevent personal injuries!**

Whenever some safety instruction is preceded by a warning triangle labelled “Danger” this is to indicate that it is not possible to definitely exclude the presence of danger to persons, engine, material and/or environment.

If, however, some safety instruction is preceded by the warning triangle labelled “Caution” this will indicate that danger of life or personal injury is not involved.

**The symbols used in the text do not supersede the safety instructions. So please do not skip the respective texts but read them thoroughly!**

**In this publication the Table of Contents is preceded by diverse instructions that among other things serve to ensure safety of operation. It is absolutely imperative that these hints be read and understood before commissioning or servicing the installation.**

### **1.1 Basic Safety Measures for Normal Operation**

- The installation may be operated only by authorized persons who have been duly trained and who are fully acquainted with the operating instructions so that they are capable of working in accordance with them.
- Before turning the installation on please verify and make sure that
  - only authorized persons are present within the working range of the engine;
  - nobody will be in danger of suffering injuries by starting the engine.
- Before starting the engine always check the installation for visible damages and make sure it is not put into operation unless it is in perfect condition. On detecting any faults please inform your superior immediately!
- Before starting the engine remove any unnecessary material and/or objects from the working range of the installation/engine.
- Before starting the engine check and make sure that all safety devices are working properly!

### **1.2 Basic Safety Measures for Servicing and Maintenance**

- Before performing any maintenance or repair work make sure the working area of the engine has been closed to unauthorized persons. Put on a sign warning that maintenance or repair work is being done.
- Before performing any maintenance or repair work switch off the master switch of the power supply and secure it by a padlock! The key must be kept by the person performing the maintenance and repair works.
- Before performing any maintenance and repair work make sure that all parts of engine to be touched have cooled down to ambient temperature and are dead!
- Refasten loose connections!

- Replace at once any damaged lines and/or cables!
- Keep the cabinet always closed. Access should be permitted only to authorized persons having a key or tools.
- Never use a water hose to clean cabinets or other casings of electric equipment!

### **1.3 Before Putting an Installation into Service after Maintenance and Repair Works**

- Check on all slackened screw connections to have been tightened again!
- Make sure the control linkage has been reattached and all cables have been reconnected.
- Make sure all safety devices of the installation are in perfect order and are working properly!

## 2 General

The **HEINZMANN** Digital Governors of the PANDAROS series have been designed as speed governors for diesel and gas engines with low and medium power. In addition to their primary purpose of controlling speed, these governors are capable of performing some other tasks and functions.

The control system consists of the control unit, the actuator, the setpoint adjusters, the sensors, and the connection cables.

The control unit includes the control electronics. At the core of the control unit is a very fast and powerful 16 bit microprocessor. The actual controller programme based on which the processor operates is permanently stored in a FLASH-EPROM.

The current engine speed is sensed by a magnetic pickup on the flywheel or a measuring wheel.

One temperature sensor can measure the engine temperature and can cause changings of governor parameters or alarm messages.

The speed setpoint, additional sensor inputs and the inputs for the analogue accessory are depending on variations. There are 5 standard variations available. More variations are possible on customer request.

All variations are available optional with integrated hand programmer.

With the serial interface ISO 9141 resp. RS 232 is communication to other devices possible.

## 3 Functions

The **HEINZMANN** electronic governors of PANDAROS series are speed governors that offer a small range of functions. Even so, in addition to speed regulation, there are depending on the variation the following functions available:

### 3.1 General Functions

#### a) Start Quantity Adjustment

For setting start quantity, minimum start quantity or maximum start quantity may alternatively be selected. If necessary either can be configured in dependence of temperature. Furthermore, variable start quantity can be provided, by which start quantity is automatically increased during start-up.

#### b) Speed Ramps

For applications where speed is not supposed to respond to changes of setpoint values as fast as possible, a speed ramp is available. According to requirements, it may be parametrized separately for increasing or decreasing speed. In addition, a separate speed ramp is provided for start-up which will make the engine ramp slowly to operating speed after starting.

#### c) All speed governing with adjustable droop

Some applications require speed governing with droop, e.g. generator parallel operation without **HEINZMANN** load measuring unit. The droop can be adjusted as desired. With droop adjusted to 0, the governor operates in isochronous mode.

#### d) Setting the speed range

The minimum and maximum speed adjustable by the (external) setpoint, can be parametrised.

#### e) Engine stop

When the switch input for engine shutdown is activated, the governor will cause the actuator to fully pull to stop direction until the engine has stopped.

#### f) Overspeed protection

An overspeed point can be parametrised. If this point is overcome, the governor will issue an alarm and the actuator will fully pull to stop direction.

#### g) Correction of PID Parameters

To optimize the dynamics for every operating point, the PID parameters may be corrected in dependence of speed, temperature and load by means of freely programmable stability maps.

**h) Speed Dependent Quantity Limitation**

It is possible to programme quantity limitation curves in dependence of speed so that for all speeds there can be torque reduction as is admissible for the engine or desired by the user.

**i) Temperature Dependent Idling Speed and Quantity Limitation**

At low temperatures, the engine can be run at some higher idling speed. With the engine warming up, idling speed is reduced to its normal value. It is possible to programme quantity limitation curves in dependence of temperature so that for every temperature there will be torque reduction available as is admissible for the engine or desired by the user.

**j) Operating Hour Meter**

The operating hours when the engine is turning (speed is detected) will be added.

**k) Failure Diagnosis and Display**

If a sensor or the actuator is at fault, an alarm is issued and there will be a change-over to emergency operation if so provided or an engine shutdown. Internal errors get detected also and they will be stored as all other failures. All failures can be read out with an external handprogrammer, the optional internal handprogrammer, or, if a communication program with communication cable is existing with a PC or laptop computer.

**l) Communication**

Two serial interface ports are available: ISO 9141 and RS-232.

**3.2 Variation specific additional Functions****3.2.1 Variation DC 6-01 (Standard Generator)**

(refer to connection diagram page 26)

The setpoint is realized with two push buttons: increase speed and decrease speed.

**3.2.2 Variation DC 6-02 (Standard General)**

(refer to connection diagram page 27)

The setpoint is given by an analogue setpoint source (voltage source 0..5 V, current 4..20 mA or potentiometer 5 k $\Omega$ ) and one switch input for fixed speed.

### **3.2.3 Variation DC 6-03 (Extended Generator 1)**

(refer to connection diagram page 28)

The speed setpoint is realized with two switch inputs to increase speed and decrease speed each.

The **HEINZMANN** load measuring unit is connected to an additional analogue input for load governing in parallel operation.

An additional switch input it to select if the switch inputs for synchronization or the analogue input from the load measuring unit is active.

### **3.2.4 Variation DC 6-04 (Extended Generator 2)**

(refer to connection diagram page 29)

The setpoint is given by an analogue setpoint source (voltage source 0..5 V, current 4..20 mA or potentiometer 5k $\Omega$ ).

Two additional analogue inputs are used for connecting the **HEINZMANN** load measuring unit for load governing in parallel mode and for connecting the **HEINZMANN** synchronizer.

A switch input is to select if the inputs of the **HEINZMANN** units or if the analogue setpoint source is active.

### **3.2.5 Variation DC 6-05 (Extended General, especially vehicle)**

(refer to connection diagram page 30)

The setpoint is given by an analogue setpoint source (voltage source 0..5 V, current 4..20 mA or potentiometer 5k $\Omega$ ) and a switch input for fixed speed.

For turbocharged engines, fuelling can be reduced to achieve smokeless operation whenever there is no boost pressure (e.g., during start-up or on load changes). The respective limit curves can be programmed accordingly.

For the purpose of oil pressure monitoring, speed/pressure dependent limit curves can be provided. If oil pressure is low, an alarm is issued; if oil pressure continues to drop, the engine is shut down.

The governor may also be adjusted as an idle/max speed governor.

## 4 Further Informations

This publication describes in detail the technical data and connections of the control electronics, of the sensors, of the setpoint adjusters and of the actuators.

The functions of the different adjustment parameters and characteristics are described in detail in the manual

*Basic Information PANDAROS 6-01, Manual-No. DG 02 006-e.*

*Basic Information PANDAROS 6-02, Manual-No. DG 02 007-e.*

*Basic Information PANDAROS 6-03, Manual-No. DG 02 008-e.*

*Basic Information PANDAROS 6-04, Manual-No. DG 02 009-e.*

*Basic Information PANDAROS 6-05, Manual-No. DG 02 010-e.*

The mode of operation of the communication programme DcDesk 2000 is described in detail in the manual

*Operation Instructions of Communication Program DcDesk 2000,  
Manual-No. DG 00 003-e.*

## 5 Block Diagram

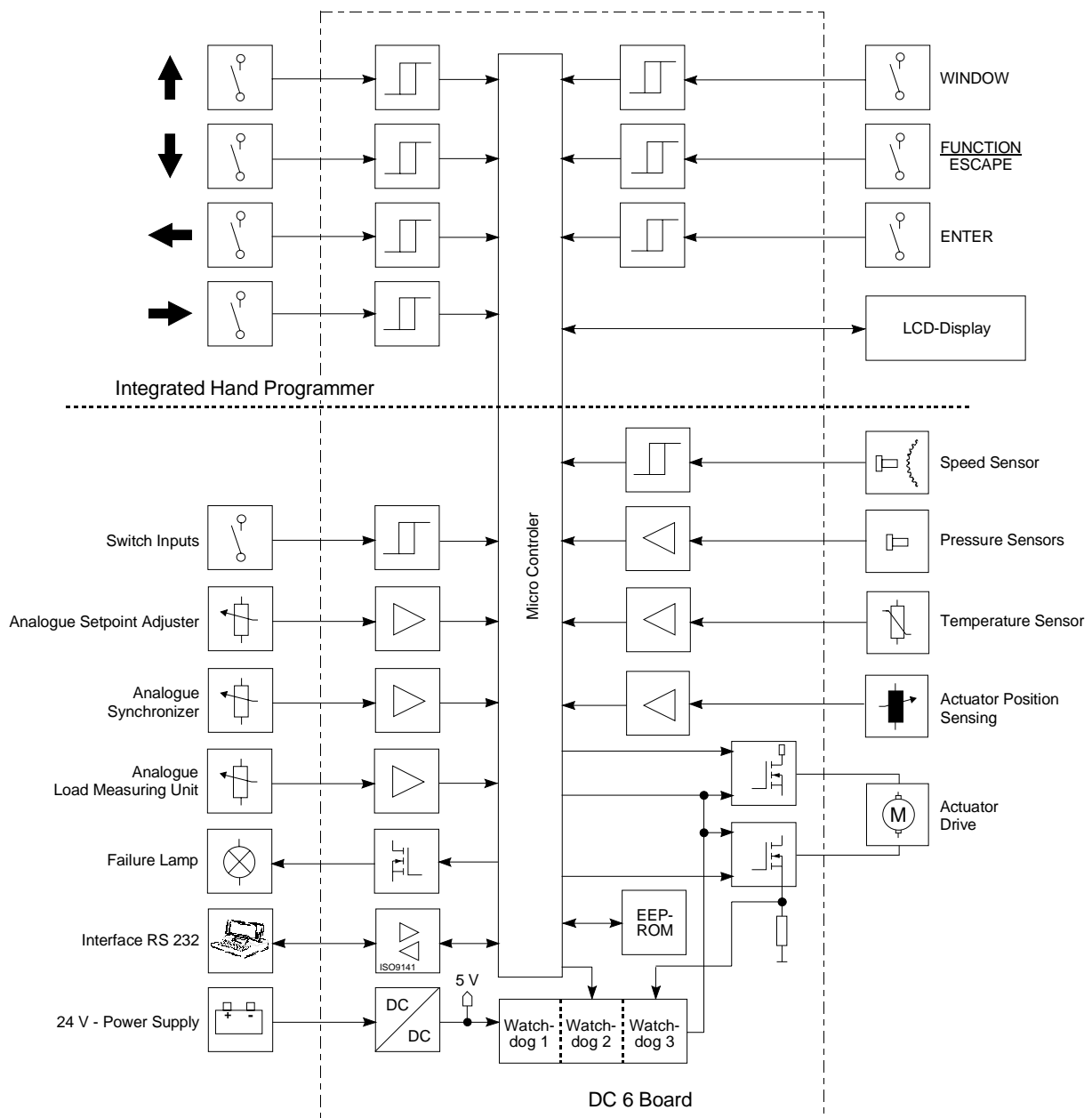

**Fig. 1: Block Diagram**

According to the different types, there are not all functions and inputs available!

## 6 Sensors

### 6.1 Overview

Sensor	Speed	Coolant Temperature	Oil Pressure	Boost Pressure
HZM Designation	IA ..	TS 01-28-PT1000	DSO 01-6 DSO 01-10	DSL/G 0..-2 DSL/G 0..-5 DSL/G 0..-10
Connection	SV 6-IA-2K 2 pole	SV 6-IA-2K 2 pole	DIN 43650 A 2 Line System	DIN 43650 A 2 Line System
Measuring Procedure	inductive, active	PT1000, passive	active	active
Measuring Range	50...9.000 Hz	-50...+150°C	0...6 bar 0...10 bar	0...2 bar 0...5 bar 0...10 bar
Supply Voltage Range		passive	10...34 V DC	12...36 V DC
Output Signal Range	0...10 V AC	ca. 700...1500 Ohm	4...20 mA	4...20 mA
Operating Temperature Range	-55...+120°C	-50...+150°C	-25...+125°C	-40...+100°C

In order to ensure maximum flexibility with regard to the sensors, the minimum/ maximum current values and the measuring ranges of the pressure and temperature sensors have been provided programmable.

## 6.2 Magnetic Pickup IA ...

### 6.2.1 Technical Datas

Operating principle	inductive sensor
Distance from sensing gear	0.5 .. 0.8 mm
Output	0 V .. 10 V AC
Signal form	Sine (depending on tooth shape)
Resistance	approx.. 52 Ohm
Temperature range	-55°C up to +125°C
Protection grade	IP 55
Vibration	< 10g, 10 .. 100 Hz
Shock	< 50g, 11 ms half sine wave
Corresponding plug	SV 6 - IA - 2K (EDV- No.: 010-02-170-00)

### 6.2.2 Installation

The installation of the pickup has to be arranged in such a way as to obtain a frequency as high as possible. Normally, the **HEINZMANN** governors of the series Pandaros are designed for a maximum frequency of 9000 Hz. Frequency (by Hz) is calculated according to the formula

$$f \text{ (Hz)} = \frac{n(\text{1/min}) * z}{60}$$

$z$  = number of teeth on the pickup wheel

Example:

$$n = 1.500$$

$$z = 160$$

$$f = \boxed{\phantom{0000}} = 4.000 \text{ Hz}$$

**NB:** It should be taken care that the speed can be measured by the pulse pickup without any bias. For best results therefore, the speed pickup should take the engine speed from the crankshaft. A suitable position for this is, e.g., the starter gear (but not the injection pump wheel).

The pickup gear must consist of magnetic material (e.g., steel, cast iron).

### 6.2.3 Tooth profile

Any tooth profile is admissible. The top width of the tooth should be 2.5 mm minimum, the gap and the depth of the gap at least 4 mm. For index plates the same dimensions are valid.

Due to tolerances, a radial arrangement of the magnetic pickup is preferable..

### 6.2.4 Clearance of Magnetic Pickup

The distance between the magnetic pulse pickup and the tooth top should range from 0.5 and 0.8 mm. (It is possible to screw in the magnetic pickup till it touches the tooth and then unscrew it for about half a turn.)

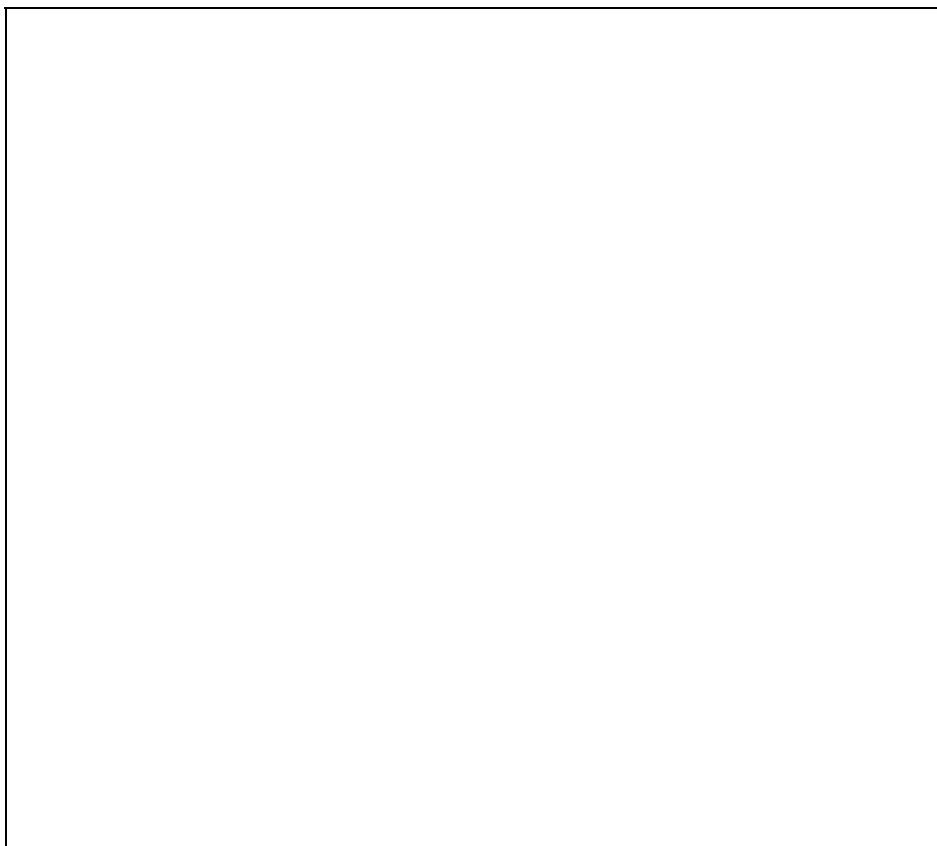

**Fig. 2: Clearance of Pickup**

### 6.2.5 Mounting Measurements

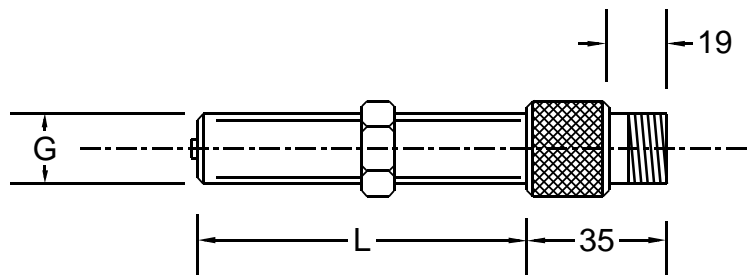

Fig. 3: Measurements of Pickup

Measures Type	L (mm)	G	Remarks
01 - 38	38	M 16 x 1,5	appropriate plug SV6-IA-2K
02 - 76	76	M 16 x 1,5	
03 - 102	102	M 16 x 1,5	
11 - 38	38	5/8"-18UNF-2A	
12 - 76	76	5/8"-18UNF-2A	
13 - 102	102	5/8"-18UNF-2A	

Ordering specification, e.g. IA 02-76

### 6.3 Cooling Medium Temperature Sensor TS 01 - 28 - PT 1000 (EDV- No.: 600 00 053 00)

Measuring range	-50°C up to +150°C
Precision	±1.5°C
Resistance at 25 °C (R25)	1000 Ohm ±0.5 %
Maximum operating voltage	5 V
Maximum operating current	3 mA
Recommended operating current	approx 1mA
Time constant in fluids	approx. 13 seconds
Admissible temperature range	
connector socket	-40°C up to +105°C
Protection grade	IP 65
Vibration	< 20 g, 10 - 300 Hz
Shock	< 50 g, 11 ms half-sine wave
Tightening torque	50 Nm ±15 %
Connector	SV 6 - IA - 2K (EDV- No.: 010 02 170 00)

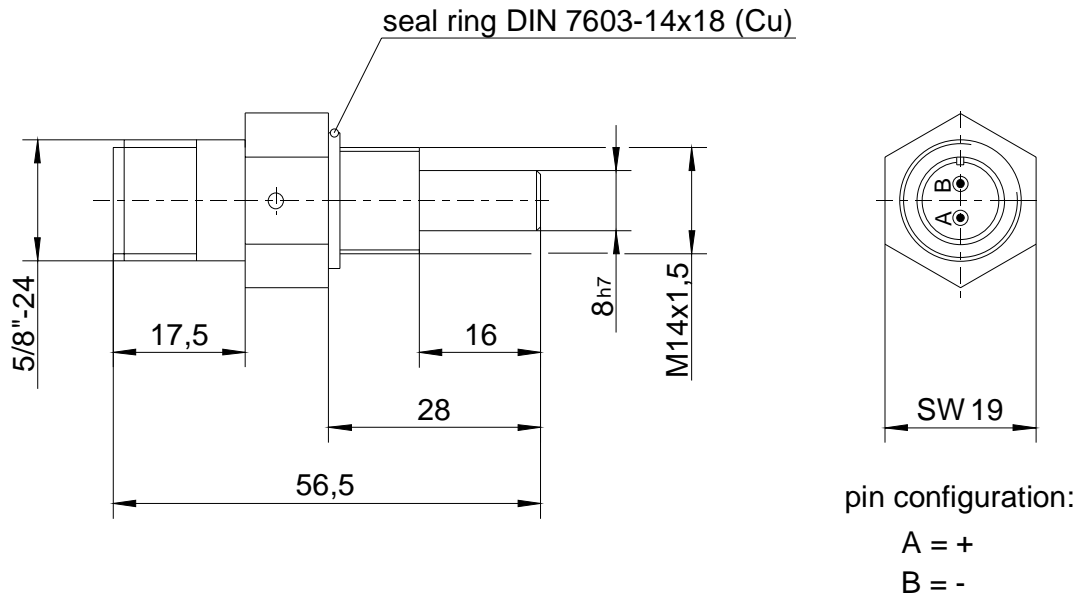

**Fig. 4: Temperature Sensor TS 01 - 28 - PT 1000**

## 6.4 Pressure Sensors

### 6.4.1 Oil Pressure Sensor

Measuring range	0 - 6 bar or 0 - 10 bar
Over pressure	15 bar resp. 20 bar
Supply voltage	10 - 34 V DC
Output signal	4 - 20 mA
Storage temperature	-25°C up to +85°C
Ambient temperature	-25°C up to +85°C
Oil temperature	-25°C up to +125°C
Protection grade	IP 65
Vibration	< 20 g, 10 - 300 Hz
Shock	< 50 g, 11 ms half-sine wave
Tightening torque	max. 25 Nm
Connection	DIN 43650-A, 2-line system

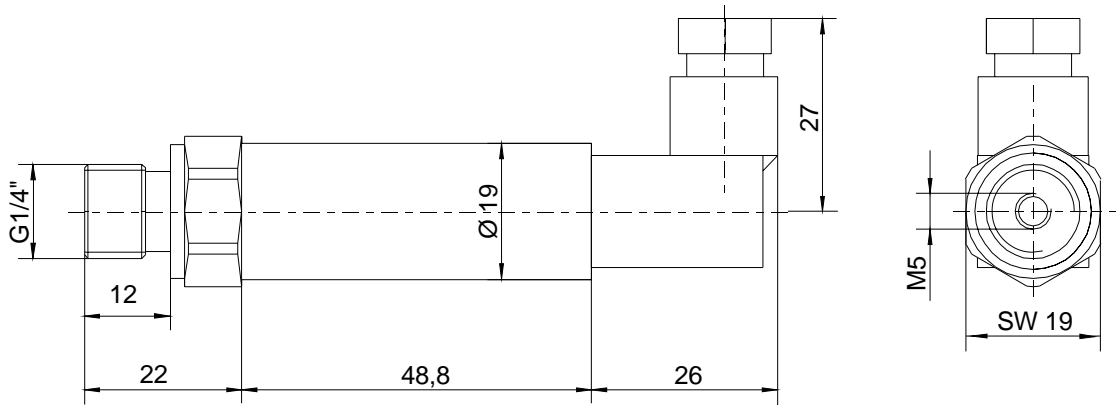

Fig. 5: Oil Pressure Sensor

Pressure Sensor	EDV- No.	Max. Operating Pressure (bar)
DSO 01 - 6	600-00-058-00	6
DSO 01 - 10	600-00-058-01	10

### 6.4.2 Boost Pressure Sensors

The boost pressure sensors are also available in an additional housing with terminal strip.

Measuring range	0 - 2 bar, 0 - 5 bar or 0 - 10 bar
Over pressure	4 bar resp. 10 bar resp. 16 bar
Supply voltage	12 - 36 V DC
Output signal	4 - 20 mA
Storage temperature	-55°C up to +100°C
Ambient temperature	-40°C up to +100°C
Protection grade	IP 65
Vibration	< 2 g, 5 - 500 Hz
Shock	< 50 g, 11 ms half-sine wave
Connection	DIN 43650-A or terminal strip, 2-line system

### 6.4.2.1 Boost Pressure Sensor with Plug

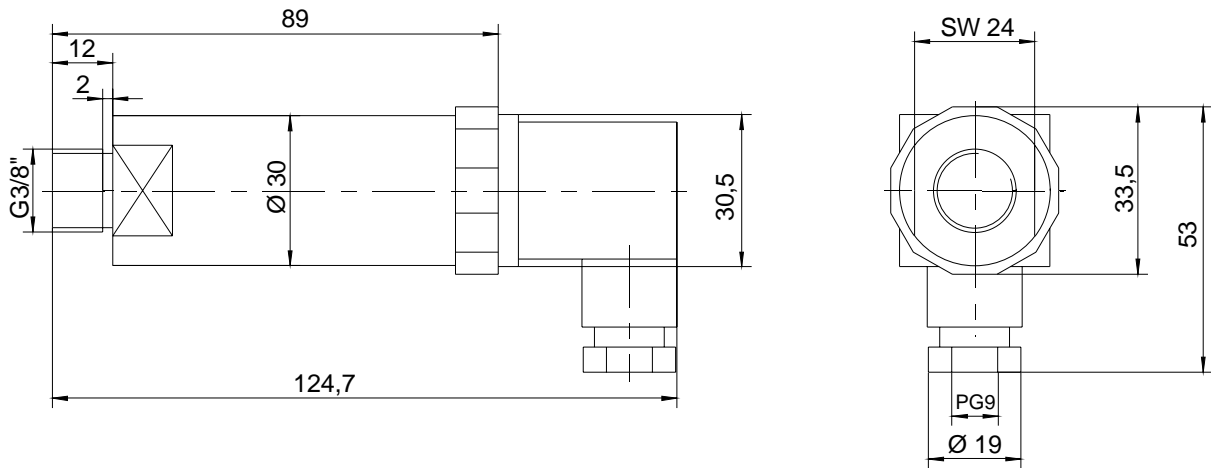

Fig. 6: Boost Pressure Sensor with Plug

Boost Pressure	EDV- No.	Max. Operating Pressure (bar rel.)
DSL 01 - 2	600-00-057-00	2
DSL 01 - 5	600-00-057-01	5
DSL 01 - 10	600-00-057-02	10

### 6.4.2.2 Boost Pressure Sensor with Housing and Terminal Strip

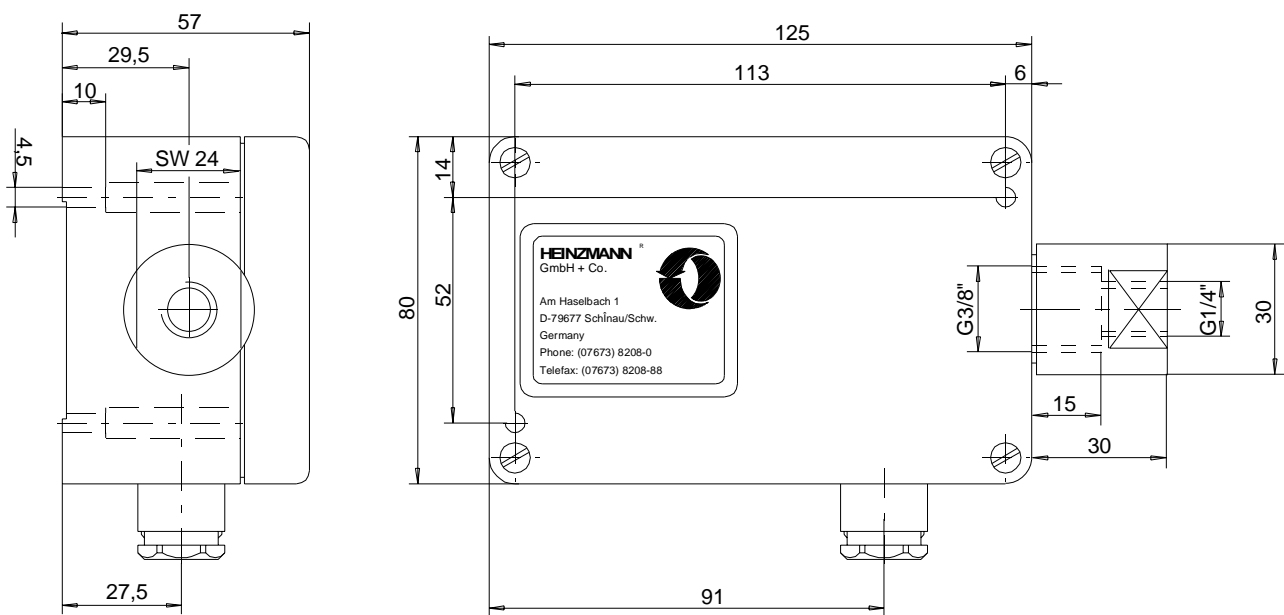

Fig. 7: Boost Pressure Sensor with Housing

<b>Pressure Sensor</b>	<b>EDV- No.</b>	<b>Max. Operating Pressure (bar rel.)</b>
DSG 04 - 2	600-00-056-00	2
DSG 04 - 5	600-00-056-01	5
DSG 04 - 10	600-00-056-02	10

## 7 Setpoint Adjusters

With regard to the variety of applications, various setpoint adjusters are available for the HEINZMANN digital speed governors of series Pandaros.

### 7.1 Setpoint Potentiometer SW 01 - 1 - b (1 turn) (EDV- No.: 600 00 041 01)

Displacement angle	approx. 312°
Resistance	5 kOhm
Temperature range	-55°C to + 120°C
Protection grade	IP 00

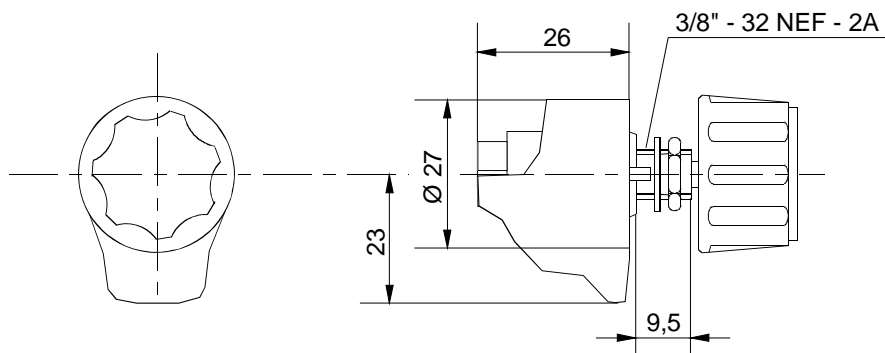

Fig. 8: Potentiometer SW 01 - 1 - b

### 7.2 Setpoint Potentiometer SW 02 - 10 - b (10- turn) (EDV- No.: 600 00 042 01)

Displacement angle	10 turns
Resistance	5 kOhm
Temperature range	-55°C to + 120°C
Protection grade	IP 00

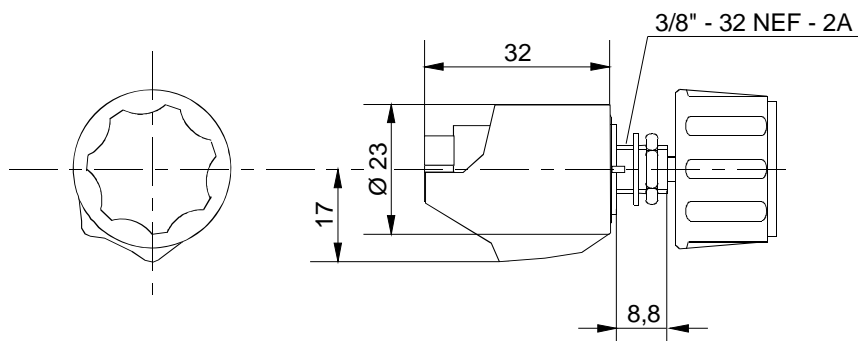

Fig. 9: Potentiometer SW 02 - 10 - b

On request, the potentiometers, as specified under 6.1. and 6.2. can be supplied with analogue adjustment knob with lock in place of the standard rotating knob. In this case, ordering specification is SW...-m.

Likewise, a clamping fixture can be installed instead of the knob. The ordering specification will then be SW ...-k.

### **7.3 Setpoint Value Adjustment by Current Signal**

For the speed setpoint value a current signal of 4 – 20 mA can be directly connected to the control unit. If the signal fails, the governor will adjust minimum speed according to the 4 mA value or use a pre-programmed substitute value.

### **7.4 Digital Presetting of Setpoint Values**

On condition that the governor is configured correctly, a digital setpoint source is possible directly with two switch inputs (increase/decrease speed), e.g. digital synchronizing manually or with PLC.

### **7.5 Setpoint Value Adjustment by Pedal**

This unit is basically an angular position transducer that translates gas pedal positions into a proportional current or voltage for 0 - 45° rotational displacement. The resulting output can be used for speed setting. For more information refer to manual E 83 005 - e.

### **7.6 Pneumatic Setpoint Adjuster**

If pneumatic setpoint adjustment is desired, the boost pressure sensors may be used to supply the signals. For detailed specifications of these sensors refer to chapter 5.5.2.

## 8 Control Unit DC 6 – 01..05

### 8.1 Specification

#### 8.1.1 General

Supply voltage	12 V DC or 24 V DC
min. voltage	9 V DC
max. voltage	33 V DC
max. ripple voltage	max. 10 % bei 100 Hz
Current consumption	max. 7 A, and max. 11 A for max. 60 Seconds
Permissible voltage dip at maximum current consumption	max. 10 % in control unit
Fuse protection of governor	12 A
Storing temperature	-40°C up to +85°C
Operating temperature	-40°C up to +80°C
Operating temperature LCD	0°C up to +50°C optional -20°C up to +70°C
Humidity	up to 98% at 55°C
Dynamic strength	max. 2 mm at 10 up to 20 Hz, max. 0,24 m/s at 21 up to 63 Hz max. 7 g at 64 up to 2000 Hz
Shock	50 g, 11 ms- half-sine wave
Protection grade	IP 00
Insulation resistance	> 1 MOhm at 48 V DC
Weight	approx. 0.5 kg
EMC	EMC Directives: 89/33/EWG, 95/54/EWG according to EMC Standards: ISO 11452-2 ISO 7637-2 ISO 7637-3 VDE 0879-3 EN 50081-2 EN 50082-2

further information on request

## 8.1.2 Inputs and Outputs

All inputs and outputs are protected against reverse-voltage and short circuit to battery plus and minus.

Speed input	for inductive sensor, with $f_i = 25$ up to 9000 Hz, $U_i = 0.5$ up to 30 V AC
Temperature input	for PT1000 / Ni1000 sensors tolerance: $< \pm 2^\circ\text{C}$ at $0^\circ\text{C}$ up to $130^\circ\text{C}$ , rest $< \pm 4^\circ\text{C}$
Reference voltage setpoint adjuster	$U_{\text{ref}} = 5 \text{ V} \pm 1 \%$ , $I_{\text{ref}} < 30 \text{ mA}$
Setpoint default analogue	$U = 0.5 \text{ V}$ , $R_e = 100 \text{ k}\Omega$ , $f_g = 15 \text{ Hz}$
or	$I = 4 \dots 20 \text{ mA}$ , $R_e = 200 \Omega$ , $f_g = 15 \text{ Hz}$
Setpoint default digital 1	$U_0 < 2 \text{ V}$ , $U_1 > 6.5 \text{ V}$ , $R_{\text{pd}} = 100 \text{ k}\Omega$
Setpoint default digital 2	$U_0 < 2 \text{ V}$ , $U_1 > 6.5 \text{ V}$ , $R_{\text{pd}} = 4.75 \text{ k}\Omega$ , oder $R_{\text{pu}} = 4.75 \text{ k}\Omega$ oder $R_{\text{pd}} = 150 \text{ k}\Omega$
Digital input engine stop	$U_0 < 2 \text{ V}$ , $U_1 > 6.0 \text{ V}$ , $R_{\text{pd}} = 4.75 \text{ k}\Omega$ or $R_{\text{pu}} = 4.75 \text{ k}\Omega$ or $R_{\text{pd}} = 150 \text{ k}\Omega$
Actuator position sensing	internal in actuator with reference feedback
analogue	$U_{\text{Reg.weg}} = 1.4 \dots 3.0 \text{ V}$ , $U_{\text{ref}} = 8 \text{ V} \pm x \%$ , $I_{\text{ref}} < 20 \text{ mA}$
digital	only with HEINZMANN-StG and Bosch EDC
Drive output	$I < 7 \text{ A}$ , $I < 11 \text{ A}$ für $T < 60 \text{ s}$ , PWM
Digital output failure lamp	$I_{\text{sink}} < 0.3 \text{ A}$ , $U_{\text{rest}} < 1.0 \text{ V}$ , $I_{\text{leck}} < 0.1 \text{ mA}$ $R_{\text{pu}} = 4.75 \text{ k}\Omega$ oder $R_{\text{pu}} = \infty$ , ground switched
Serial interface ISO 9141, RS 232	variable from 2.4 kbit/s up to 57.6 kbit/s standard 9.6 kbit/s
Additional Inputs	
only for DC 6 – 03..05	$U_e = 0..10 \text{ V}$ , $R_e = 20 \text{ k}\Omega$ , $f_g = 15 \text{ Hz}$
or	$U_e = 0.5 \text{ V}$ , $R_e = 100 \text{ k}\Omega$ , $f_g = 15 \text{ Hz}$
or	$I_e = 4 \dots 20 \text{ mA}$ , $R_e = 200 \Omega$ , $f_g = 15 \text{ Hz}$
or	$U_0 < 2 \text{ V}$ , $U_1 > 6.5 \text{ V}$ , $R_{\text{pd}} = 4.75 \text{ k}\Omega$
or	$R_{\text{pu}} = 4.75 \text{ k}\Omega$ oder $R_{\text{pd}} = 150 \text{ k}\Omega$

## 8.2 Measurements

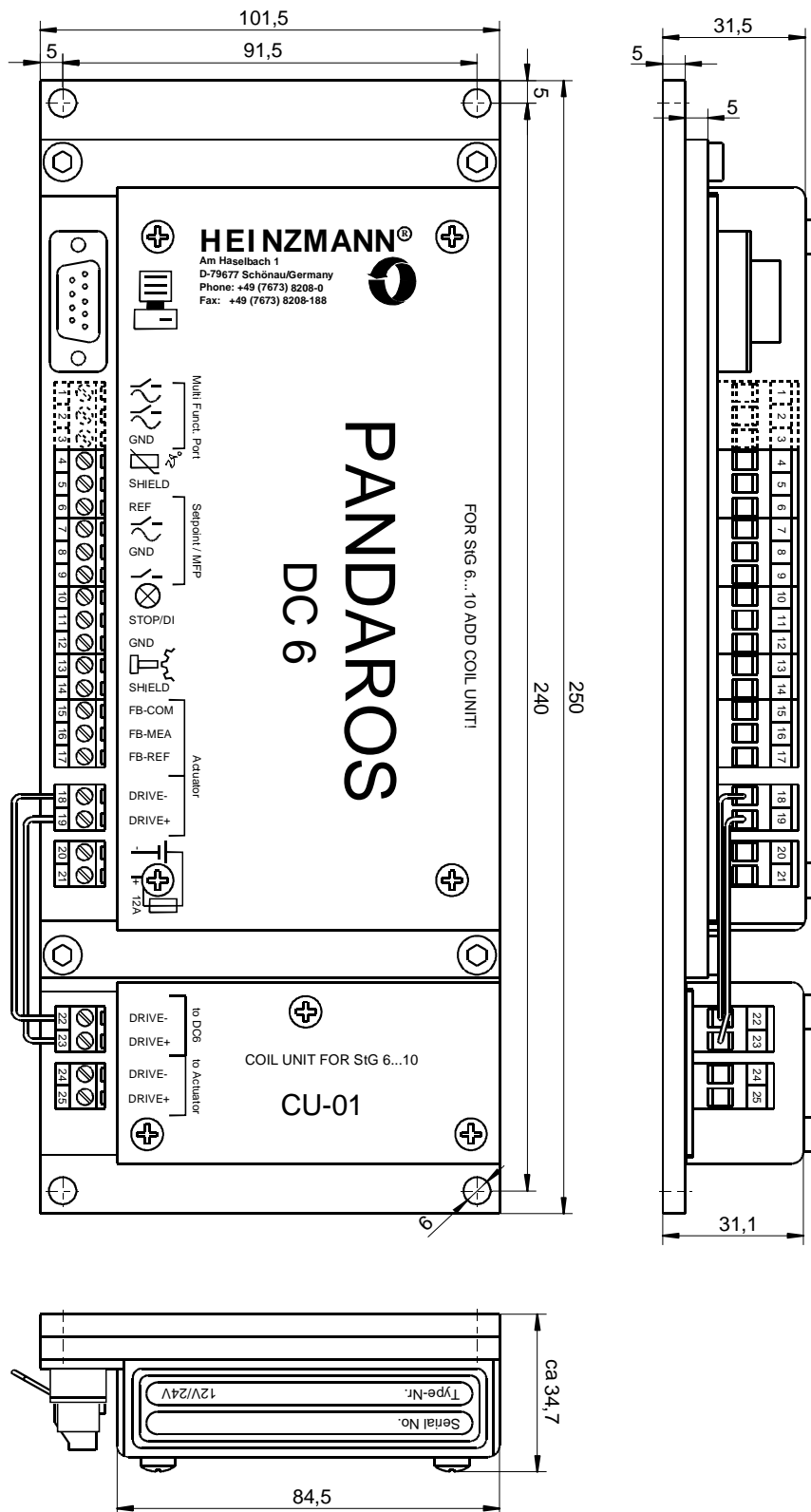

**Fig. 10: Housing of Control unit DC 6-01..05 without Handprogrammer**

Note: The terminals 1 to 3 are not available at the standard versions DC 6-01 and DC 6-02.

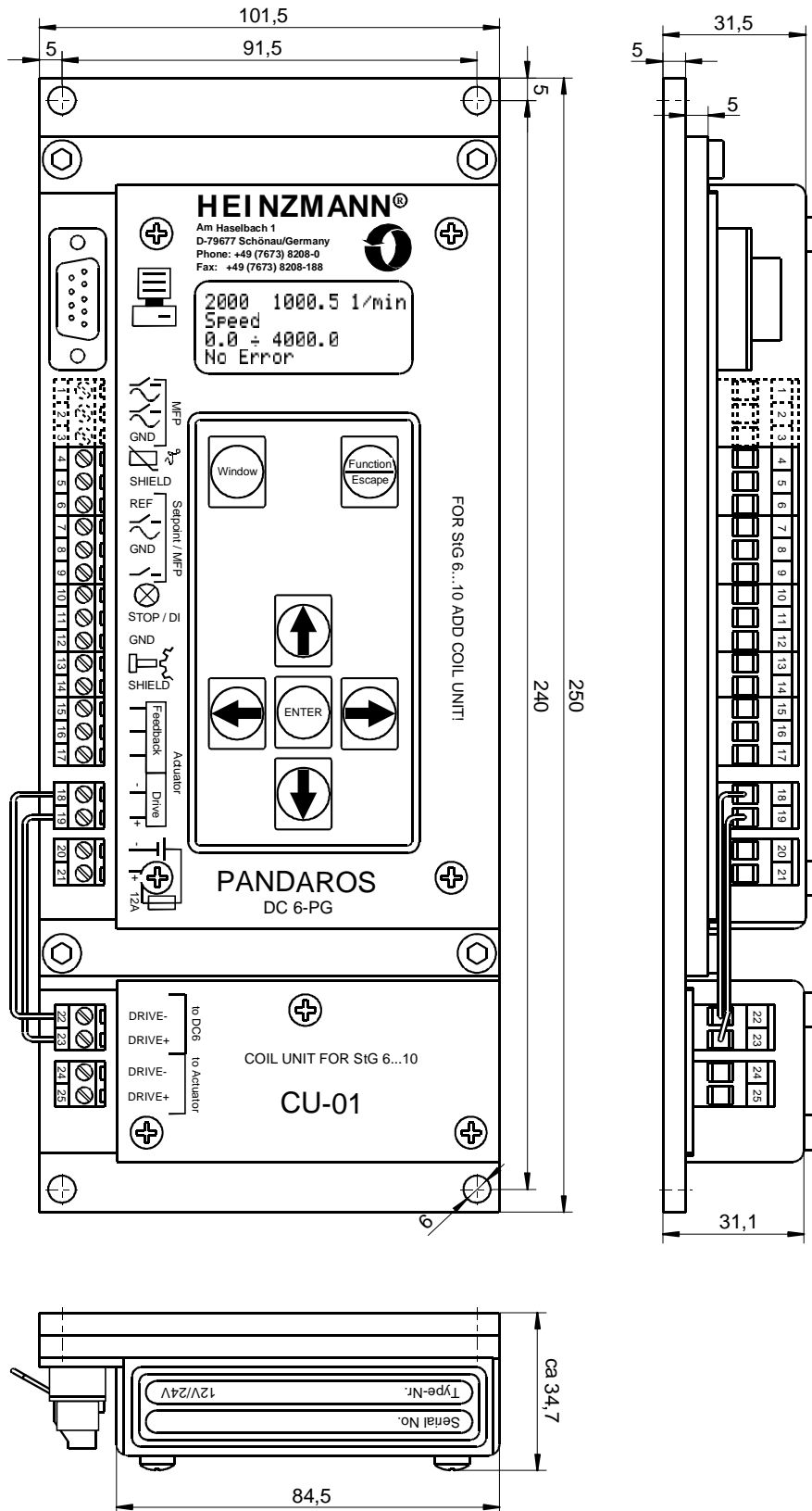

**Fig. 11: Housing of Control unit DC 6-01..05 with integrated Handprogrammer**

Note: The terminals 1 to 3 are not available at the standard versions DC 6-01 and DC 6-02.

### **8.3 Mounting**

When selecting the location, care should be taken for easy access in order to facilitate read-out of the failure indication and replacement of the device under field conditions. Any mounting position is admissible. When fitting the device directly on the engine, it should be mounted using vibration absorbers.

## 9 Actuators

### 9.1 Design and Mode of Operation

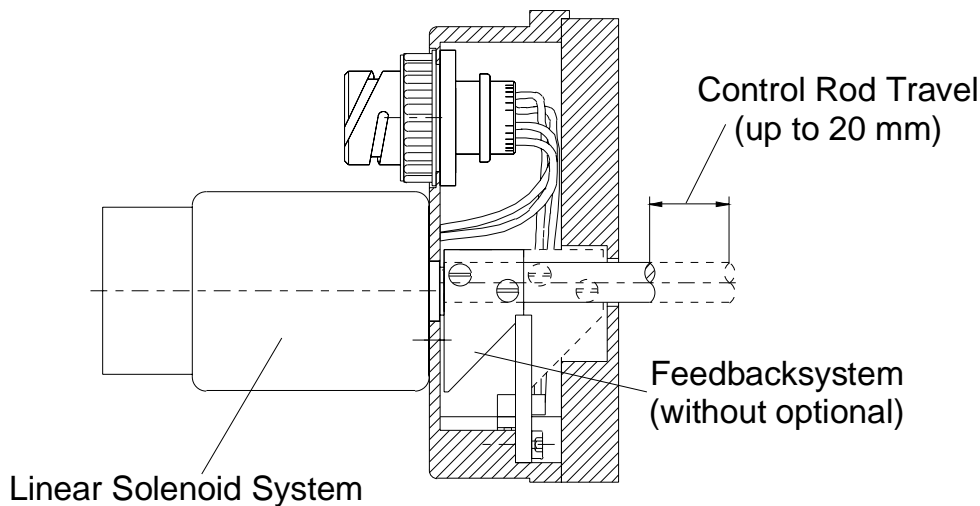

**Fig. 12: Sectional Drawing of Actuator**

The Linear Actuators LStG 20 and LstG 40 are mounted directly onto the injection pump.

The Linear Actuator is driven by an electric linear operating magnet. The armature shaft of this linear operating magnet is fixed to the control rod of the injection pump by a custom specific connection. By varying energizing of the magnet the spring loaded armature shaft is moved with the magnet's force working in the direction of maximum fuel quantity and the spring force working in the direction of stop position.

The position of the control rod is sensed by a contactless working feedback system and transmitted to the control unit. By this, the control unit is able to rapidly determine the linkage adjustment that will be necessary in case of speed changes and to variate the current accordingly. Optionally, this feedback system can be dropped. In this case, position sensing is achieved by simply measuring the current of the magnet system. This sensing method, however, is less accurate.

Optionally, the LStG 40 is also available equipped with an additional external stop lever, offering the possibility of executing an emergency shutdown. This will, however, require to overcome the actuating electric force working in the direction of 100 %. So when executing an emergency stop by means of the stop lever the voltage supply should be cut off first.

Due to the fully enclosed mounting, the control linkage is completely protected which will ensure a long and maintenance-free service life of the actuators.

### 9.2 Installation

For the different pump systems, a variety of assembly kits is provided consisting mainly of the adapter plate and the customer-specific linkage connection.

The assembly kits come with detailed assembling instructions which will help the user to do the mounting easily by himself.

### 9.3 Specification

	<b>LStG 20</b>	<b>LStG 40</b>
Maximum control rod travel	18 mm	21 mm
Spring power of back spring in stop position	approx. 15 N	approx. 32 N
Spring power of back spring in full position	25 N	50 N
Maximum positioning force	approx. 30 N	approx. 95 N
Maximum current consumption	6 A	10 A
Current consumption in operation	1 .. 3 A	3 .. 5 A
Coil resistance of governing magnet	1,7 Ohm	0,7 Ohm
Storage temperature	-55°C up to +110°C	-55°C up to +110°C
Ambient temperature in operation	-40°C up to +90°C	-40°C up to +90°C
Humidity	up to 100 %	up to 100 %
Protection grade	IP 55	IP 55
Weight without adapter plate	approx. kg	approx. 4 kg

### 9.4 Measurements

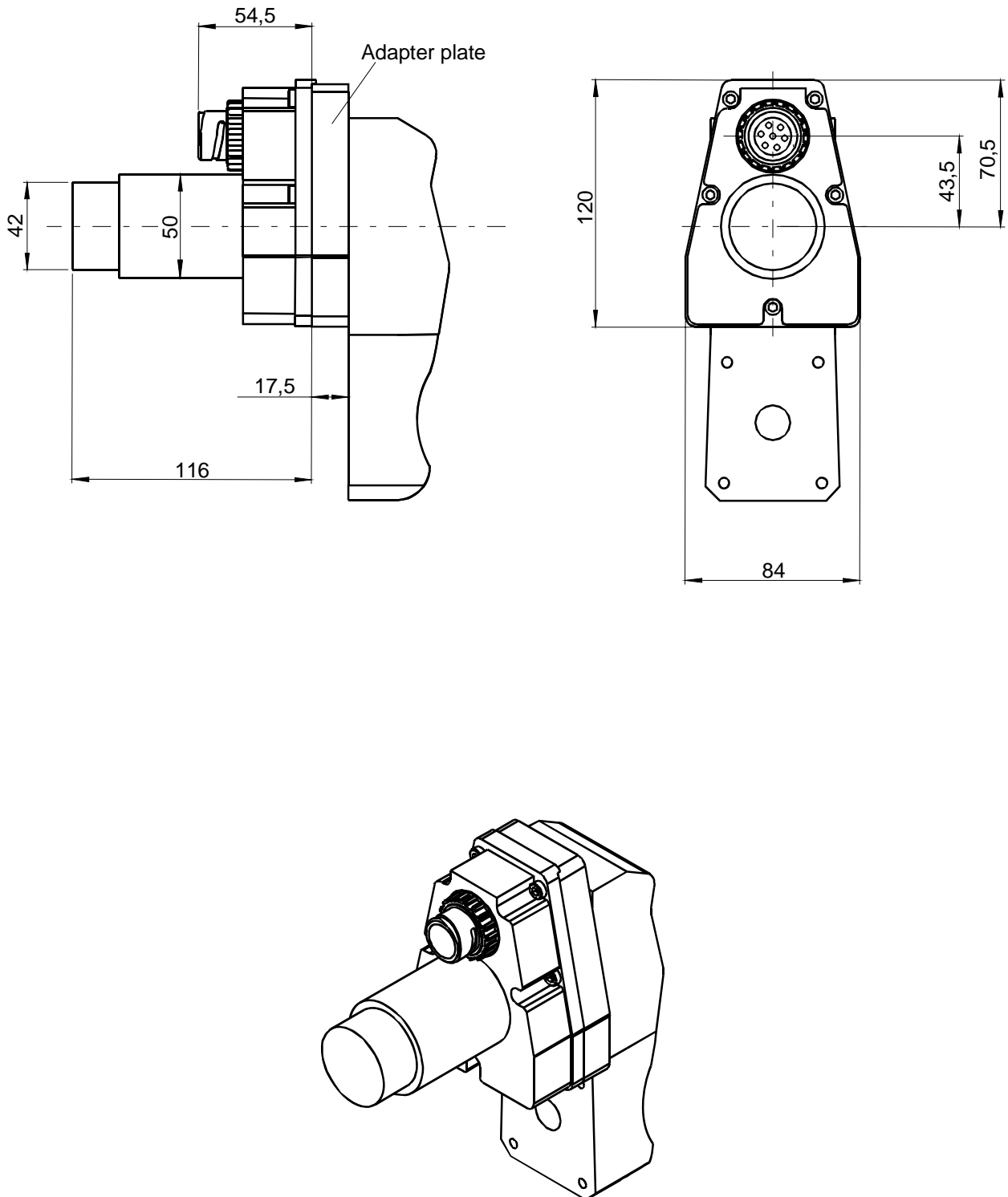

**Fig. 13: Actuator LStG 20**

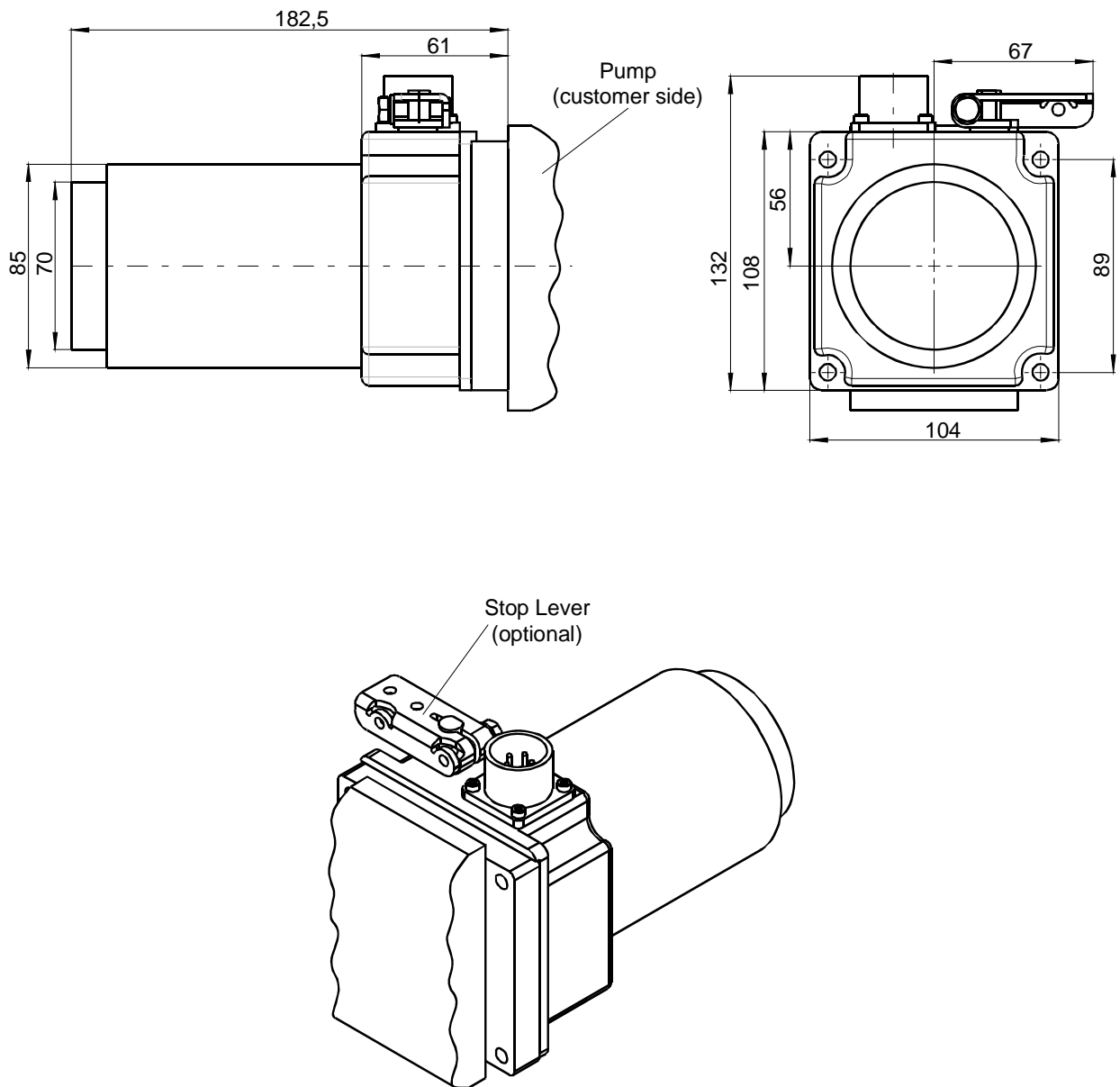

**Fig. 14: Actuator LStG 40**

## 10 Electrical Connection

The electrical connection possibilities are depending on the variation of the control unit.

### 10.1 Connection for variation DG 6-01 (Standard Generator)

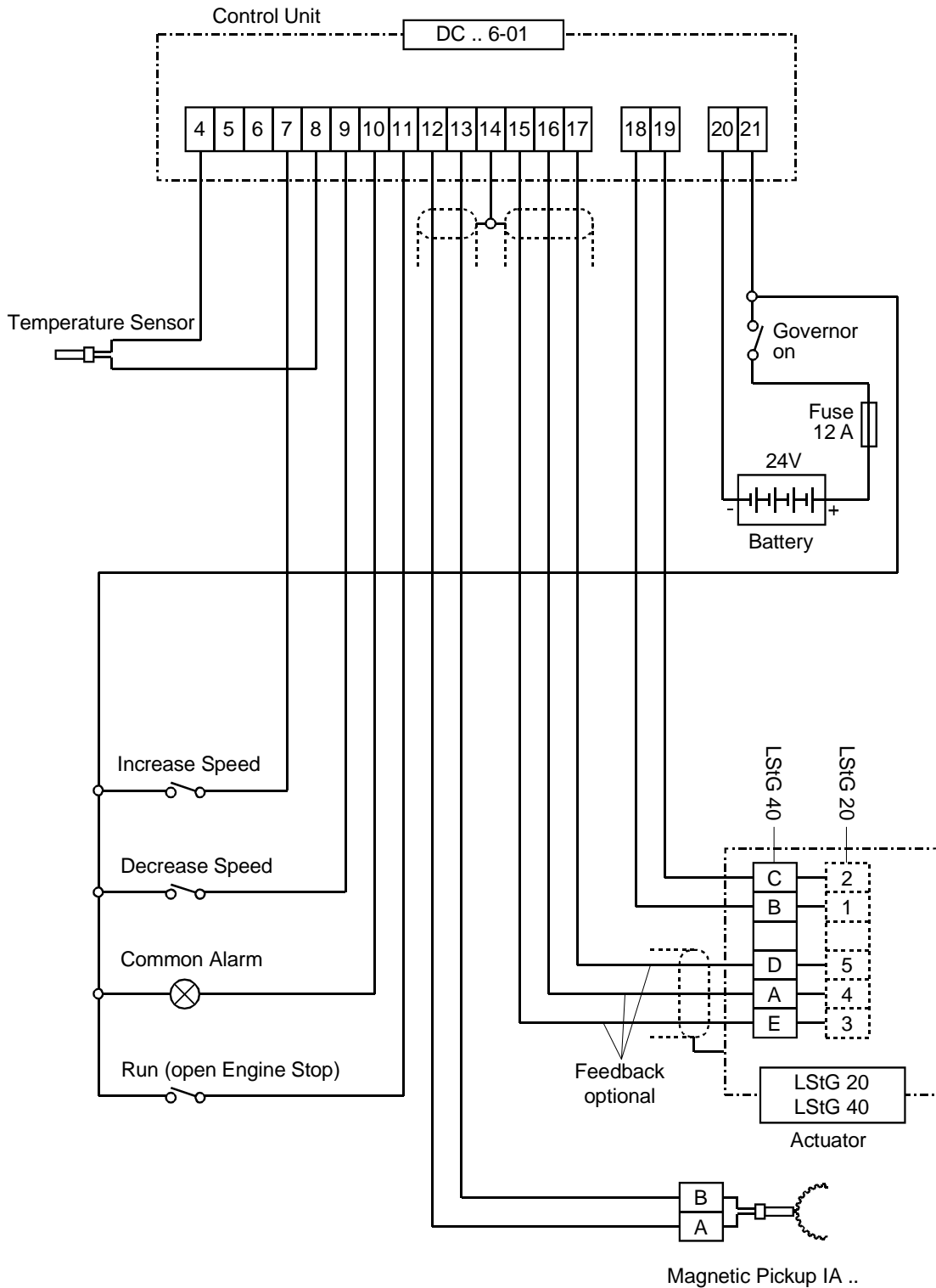

Fig. 15: Connection Diagram for Variation DG 6-01

### 10.2 Connection for variation DG 6-02 (Standard General)

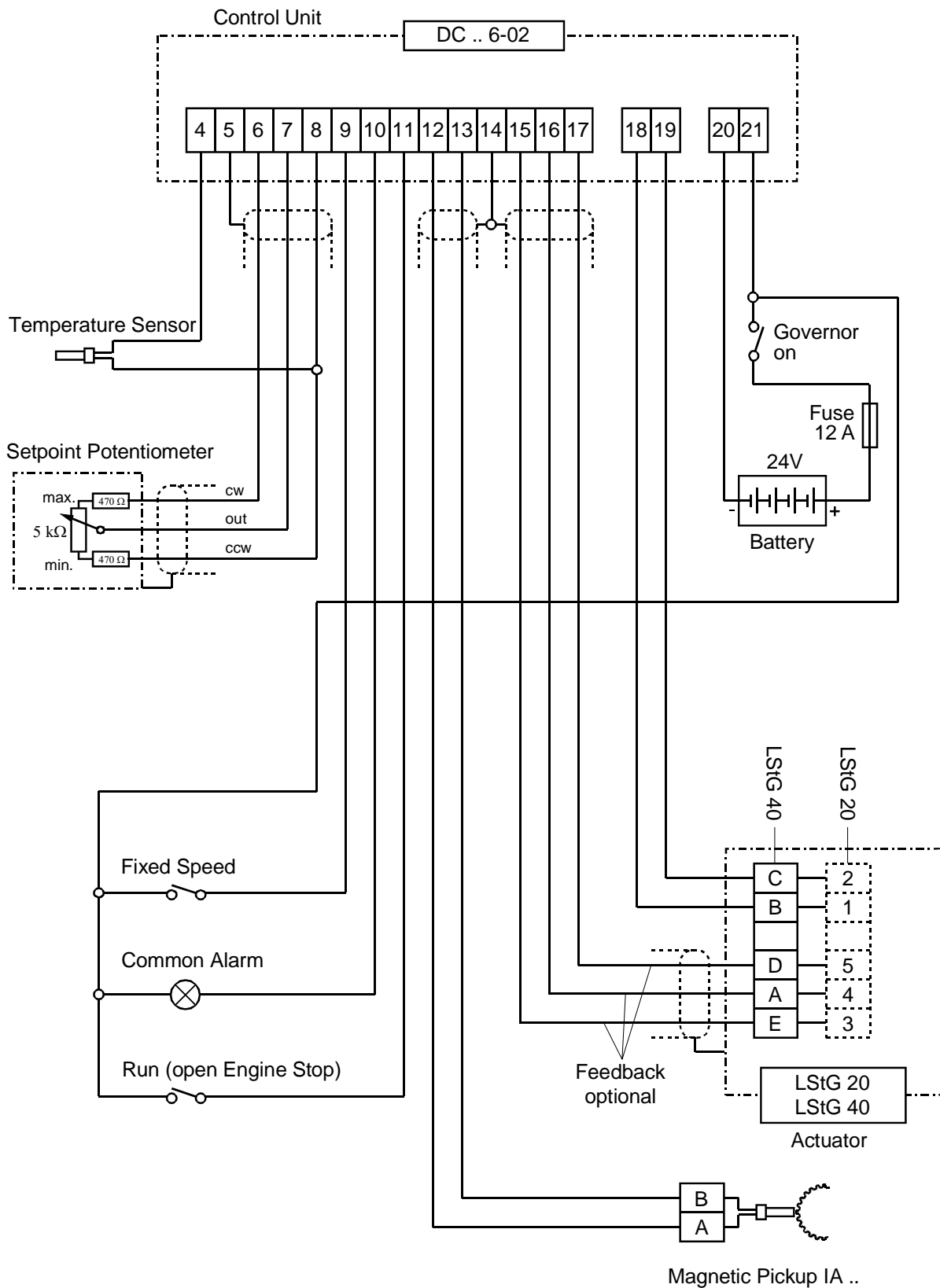

Fig. 16: Connection Diagram for Variation DG 6-02

### 10.3 Connection for variation DG 6-03 (Extended Generator 1)

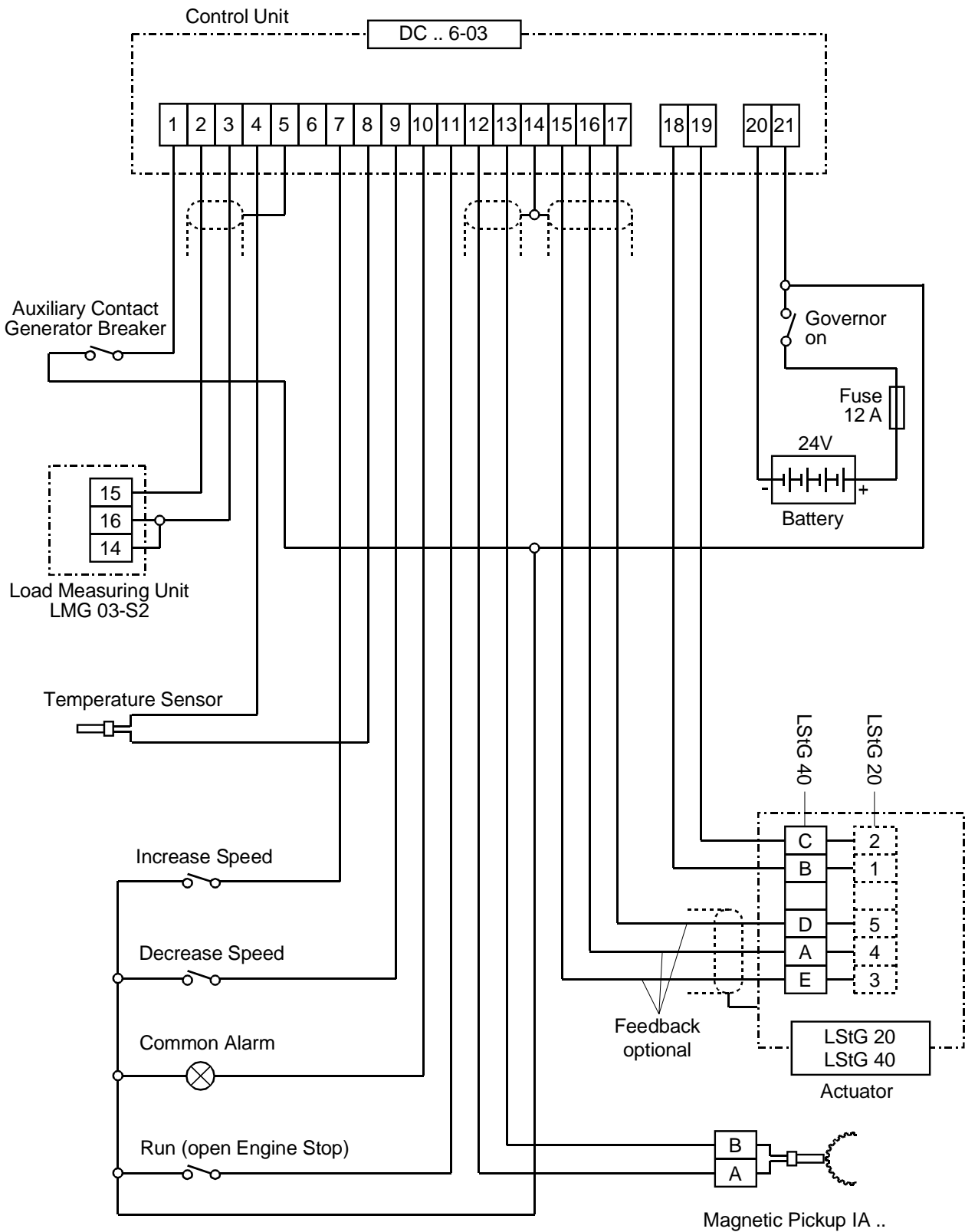

Fig. 17: Connection Diagram for Variation DG 6-03

### 10.4 Connection for variation DG 6-04 (Extended Generator 2)

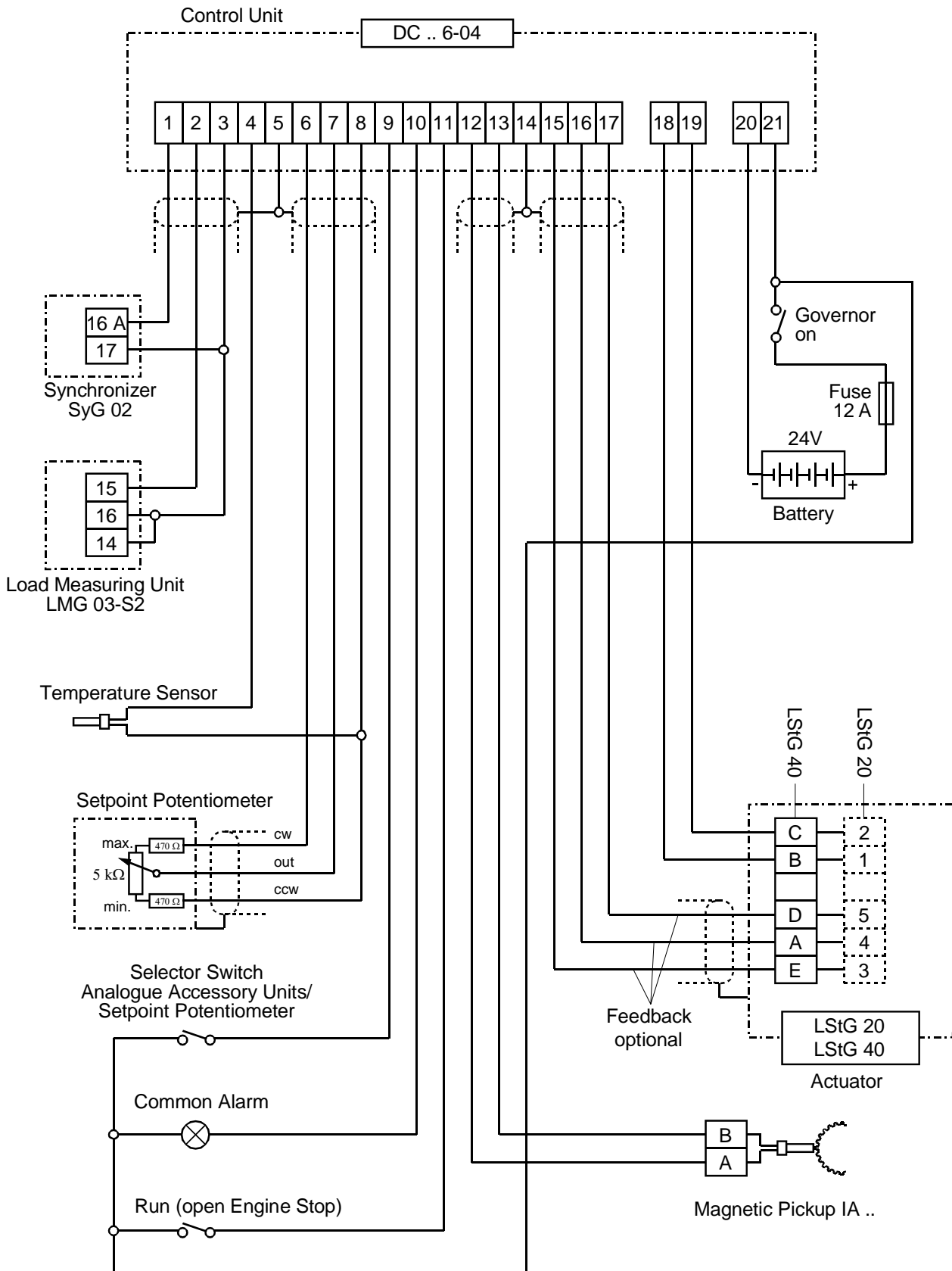

Fig. 18: Connection Diagram for Variation DG 6-04

### 10.5 Connection for variation DG 6-05 (Extended General)

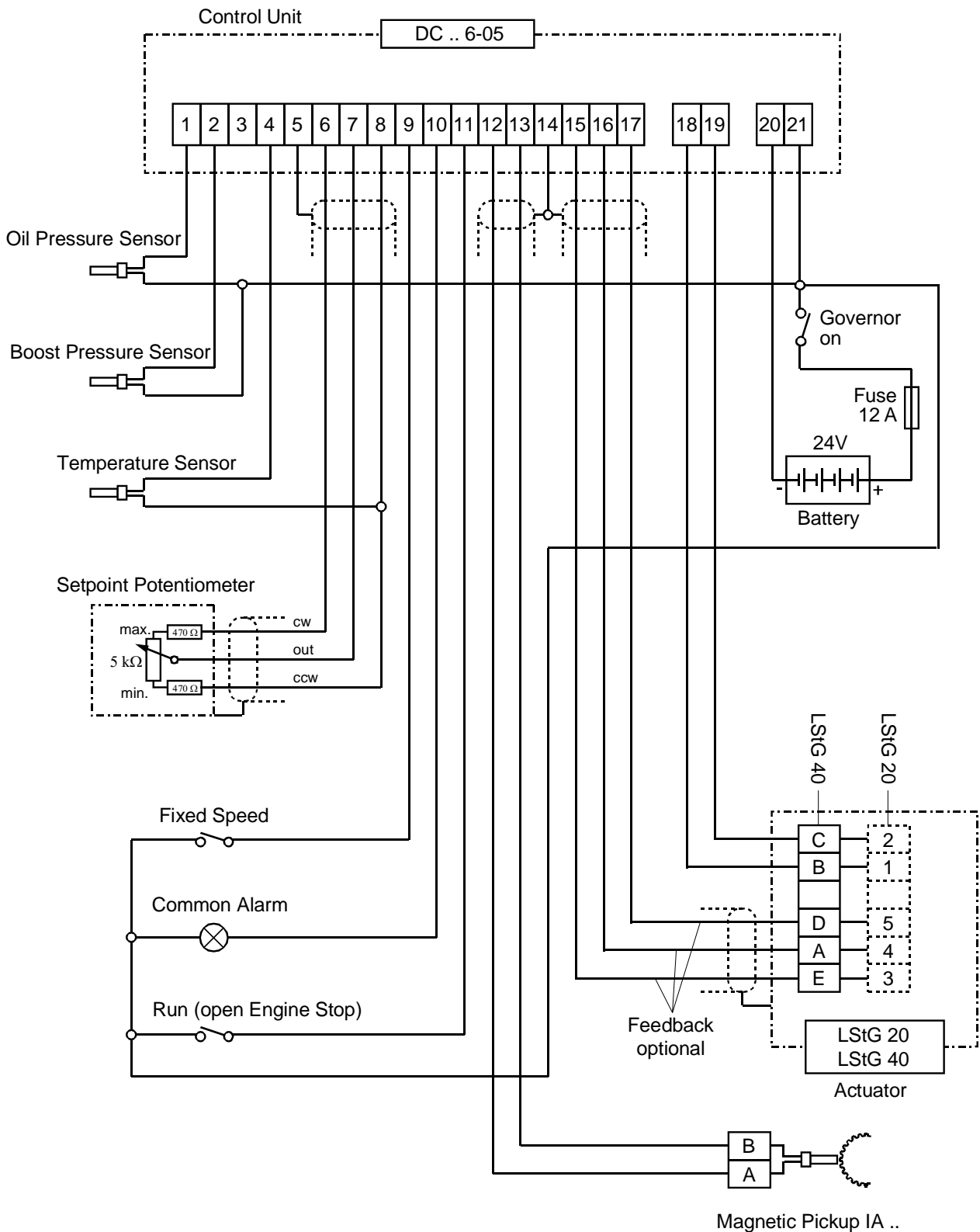
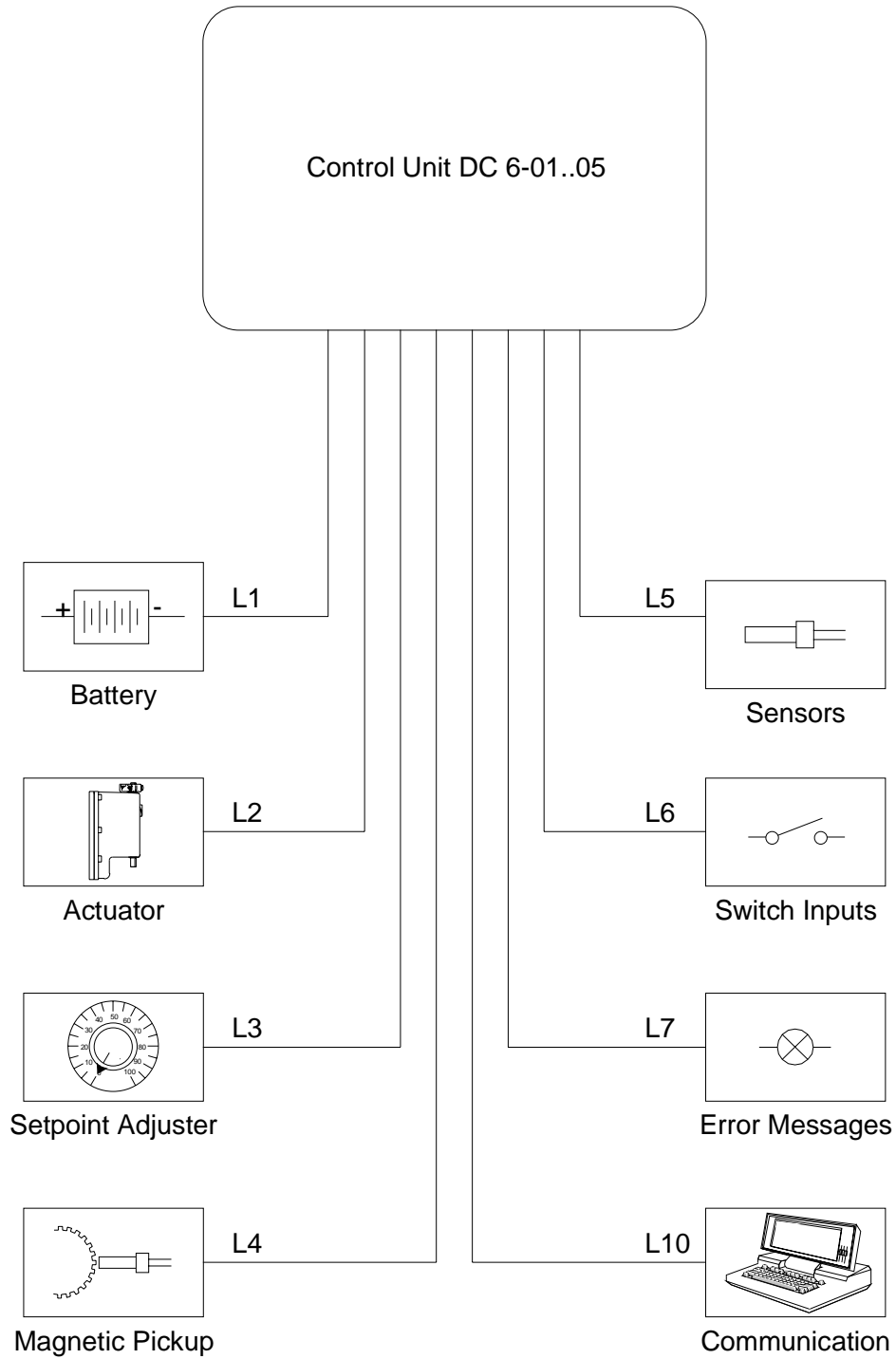

Fig. 19: Connection Diagram for Variation DG 6-05

### 10.6 Harness

Important: It is not possible to use all offered signals at the same time, because some inputs have to be assigned differently depending on the variation.



**Fig. 20: Cable Designation**

The allowed length and necessary cross-sections of the cables to connect are as follows:

L 1	Power supply	max. 15 m	2 x 2.50 mm <sup>2</sup>
L 2.1	Actuator feedback		3 x 0.75 mm <sup>2</sup>
L 2.2	Actuator drive	up to 10 m	2 x 2.50 mm <sup>2</sup>
		over 10 - 20 m	2 x 4.00 mm <sup>2</sup>
L 3.1	Setpoint potentiometer		3 x 0.75 mm <sup>2</sup>
L 3.2	4 - 20 mA input		2 x 0.75 mm <sup>2</sup>
L 3.3	0 - 5 V		2 x 0.75 mm <sup>2</sup>
L 3.4	Synchronizer		2 x 0.75 mm <sup>2</sup>
L 3.5	Load measuring unit		2 x 0.75 mm <sup>2</sup>
L 4	Magnetic pickup		2 x 0.75 mm <sup>2</sup>
L 5.1	Temperature sensor		2 x 0.75 mm <sup>2</sup>
L 5.2	Boost sensor		2 x 0.75 mm <sup>2</sup>
L 5.3	Oil pressure sensor		2 x 0.75 mm <sup>2</sup>
L 6.1	Engine stop		1 x 0.75 mm <sup>2</sup>
L 6.2	Increase speed		1 x 0.75 mm <sup>2</sup>
L 6.3	Decrease speed		1 x 0.75 mm <sup>2</sup>
L 6.4	other switch functions		1 x 0.75 mm <sup>2</sup>
	(the switches have to be supplied with battery plus)		
L7	Error message		1 x 0.75 mm <sup>2</sup>
	(the error lamp has to be supplied with battery plus, ground is switched)		

## 11 Parametrization Possibilities

The software for the **HEINZMANN** series Pandaros has been designed in a way that will allow programming both at the **HEINZMANN** factory and by the engine manufacturer.

Since erroneous programming can cause considerable damages, full use should be made of the level structure and the user masks.

As a principle, first programming should always be conducted by experienced personnel and must be checked before first commissioning the engine. If possible, a **HEINZMANN** specialist should be consulted when first programming is performed.

The following sections describe the possibilities of parametrizing the control unit:

### 11.1 Parametrization at the Factory

During final inspection at the factory, the functionality of the unit is checked by a test programme. If the operational data for the control unit is available, the test programme is carried out using this data. It is then only the dynamics data and if need be the fuel limitations and sensors that will have to be calibrated on the engine.

### 11.2 Parametrization with the Hand Held Programmer 3

All parametrization can also be done by means of the hand held programmer 'Programmer 3'. This handy device is particularly suited for development and series calibration as well as for servicing.

### 11.3 Parametrization with the Keyboard on the Control Unit

The parametrization is here the same as with the external hand held programmer 3.

### 11.4 Parametrization with the PC

Parametrization can also be conducted using a PC and the comfortable **HEINZMANN** software DC DESK. As compared with the hand held programmer, it offers the great advantage of having various curves graphically represented on the screen and being at the same time able to introduce changes as well as of having time diagrams displayed without an oscilloscope when commissioning the control unit on the engine. Furthermore, the PC offers a better overview as the PC programme has a menu structure and allows to have several parameters continuously displayed.

Besides, the PC programme permits to save and download the operational data to and from diskettes.

### **11.5 Parametrization with User Masks**

Principally, parametrization may be performed with the help of user masks that have been provided by **HEINZMANN** or may conveniently be created by the user himself. Within a user mask, only those parameters are accessible that are actually needed.

### **11.6 Transferring Data Sets**

Once parametrizing a particular engine model and its application has been completed, the data set can be saved (in the hand held programmer or on a floppy disk). For other applications of the same kind the data set can then be downloaded into the respective control units.

### **11.7 Assembly Line End Programming**

This type parametrizing is used by the engine manufacturer during the test bench run when the control unit is programmed in accordance with the engine requirements as laid down in the order.

## 12 Starting the Engine - Brief Instructions

- 11.1 Adjust clearance of magnetic pulse pickup.
- 11.2 Check program with respect to relevant parameters: number of teeth, speed, etc.
- 11.3 Calibrate sensors and setpoint adjusters, if necessary.
- 11.4 Make autoadjustment of actuator.
- 11.5 Set point potentiometer in mid-position:
  - P - Gain to 50
  - I - Stability to 0
  - D- Derivative to 0

If the dynamic values have already been determined for an installation, they can be programmed directly at this point.

Attention: Overspeed protection must be guaranteed!

- 11.6 Start engine and run it up to nominal speed using the set point potentiometer.
- 11.7 Increase gain (P-fraction) up to instability and reduce until stability is attained.  
Increase stability (I-fraction) up to instability and reduce until stability is attained.  
Increase derivative (D-fraction) up to instability and reduce until stability is attained.

With these values set, engine speed is to be disturbed briefly (e.g., by shortly pressing the stop switch), and the transient oscillations are to be observed.

- 11.8 Check over the entire speed range.

If for maximum and minimum speed other values than the programmed ones should result, this will be due to tolerances of the set point potentiometer. If the speed derivation is not acceptable, it will be necessary to measure the setpoint source.

- 11.9 Gain-correction (P-correction) for gas engines resp. for variable speed governors with larger speed ranges; adjust map if necessary.
- 11.10 Checking the remaining program items, e.g., starting fuel injection, ramp time, etc.

## 13 Order Information

### Control Unit:

Designation DC X .6 - 0Y - (PG)

X = used actuator type LStG 20 or LStG 40

Y = application variation 1 .. 5 (refer to the connection diagrams)

PG = when integrated Programmer is required, **only**

Before delivery, the control unit will be conformed on the hardware side to the application variation inclusive the actuator type. While doing so, the analogue inputs are calibrated, if necessary. The included software correspond to the application. All further adjustments as e.g. teeth number, speed range, limitation curves, dynamic parameters, start procedure etc. have to be set by the customer himself.

### Actuator:

Here an actuator designation has to be given, as listed in chapter 8.

### Magnetic Pickup:

Here an magnetic pickup designation has to be given, as listed in chapter 6.2.5.

### Additional Sensors:

If additional sensors or a setpoint adjuster is necessary, the order informations can be taken from the corresponding chapters.

### Harness:

Generally it is recommended to produce the harness at **HEINZMANN**. Therefore the needed cable length for each connections has to be given.

The wiring to the actuator and to the magnetic pickup has to be done by **HEINZMANN** generally, because here plugs from **HEINZMANN** are used where the contacts of the cables have to be soldered.

The order designation of each cable can be taken from the chapter 10.6.

## 14 Order Specifications for Manuals

There is no charge for our technical manuals ordered in reasonable quantities.

Order the necessary manuals on our speed governors from your nearest **HEINZMANN location**.

(Please click on “HEINZMANN location” to see the list of our subsidiaries and agents in the world).

### **Please include the following information:**

- your name,
- the name and address of your company (you can simply include your business card),
- the address where you want the manuals sent (if different from above),
- the number(s) (as on front page bottom right) and title(s) of the desired manual(s),
- or the technical data of your **HEINZMANN** equipment,
- the quantity you want.

You can directly use the following fax-form for ordering one or several manuals.

Most of the manuals are available as Acrobat PDF-files, too. On request they can be send via e-mail.

We solicit comments about the content and the presentation of our publications. Please, send your comments to:

### **HEINZMANN GmbH & Co. KG**

Service Department

Am Haselbach 1

D-79677 Schönau

Germany

# Fax Reply

## Order for HEINZMANN technical manuals

**Fax-Hotline +49 7673 8208 194**

Please send me the following manuals:

Quantity	No. of the manual	Title

Please send me your new sales documentation about

( ) the HEINZMANN Analogue Governors      Application:.....

( ) the HEINZMANN Digital Governors      Application:.....

( ) the HEINZMANN Gas Engine Equipment      Application:.....

Company .....

Contact Person.....

Department .....

Address..... Country/Code/Town.....

Phone..... Fax .....

E-Mail.....

Activity.....

Date .....