

## KRONOS-CARBURETION SYSTEMS / AFR-CONTROL

This sheet helps the HEINZMANN application engineers to calculate and advice the proper carburetion equipment for your gas engine application. Please fill in this form and do not hesitate to contact HEINZMANN in case of doubts or questions. For identical applications this procedure will not be required as HEINZMANN will inform you about part numbers, commissioning instructions and settings. Please use always the latest order form which you can download at:

<http://www.heinzmann.com/en/engine-and-turbine-management/system-solutions/gas-engine-management>

### CUSTOMER INFORMATION

**Company:**

**Division:**

**Contact person:**

**Customer-ID:**

**Date:**

**Email:**

**Fax:**

**Phone:**

**Address:**

### ENGINE DATA

**Engine type:**

**Configuration:**

In-line engine

V-engine

**Turbo charger:**

Yes

No

**Max. boost pressure:**

bar abs.

**Engine displacement:**

liter

**No. of cylinders:**

**Vol. eff. (Ve):**

**Rated power:**

kW

**n<sub>start</sub>:**

rpm

**n<sub>Nominal</sub>:**

rpm

**Mech. efficiency (η):**

**Max. manifold temp:**

°C

**λ desired:**

**No. of teeth at the starter ring:**

**Application:**

(e.g. net parallel / island mode)

### MIXING UNIT(S)

**Location (see overleaf):**

DTNA

DTTC

BTTTC

**For V-engines:**

Single mixing unit

Double mixing unit

### THROTTLE VALVE

**Throttle valve:**

required

not required

**For V-engines:**

single throttle valve

double throttle valve

**Lever:**

required

not required

**Configuration:**

on mixing unit

stand-alone

### GAS CONTROL VALVE

Components of the gas train such as gas valve, gas filter and in particular the zero-pressure regulator form an inseparable part in order to obtain an optimal functioning fuel system. HEINZMANN has the experience and the knowledge to supply you the right components, including the certification.

**Operation:**

manual

by AFR-control with

(e.g. Lambda sensor, broadband λ sensor, CH<sub>4</sub> sensor)

or power feed back

**For V-engines:**

single valve

double valve

**Gas train:**

required

not required

**Cable length:**

meter

## FUEL PROPERTIES

**Lower heat value:** MJ/nm<sup>3</sup>      **Gas-density:** kg/nm<sup>3</sup>  
**Stoichiometric air requirement:** m<sup>3</sup>/m<sup>3</sup>      **Range** (only for variable fuel): to % CH<sub>4</sub>  
**If fuel properties are not known:** -gas (e.g. natural, landfill, L/H-gas etc.)

## GENERAL

**Enquiry for the following volume:** 1-5 items  
**Number of items within a year:**  
**Communication program DcDesk 2000:** required      not required  
**Commissioning:** required      not required  
**Training course:** required      not required  
**Governmental requirements / certificates:**

## HEINZMANN KRONOS AIR FUEL RATIO CONTROL

### Draw through natural aspirated DTNA

### Draw through turbo charged DTTC

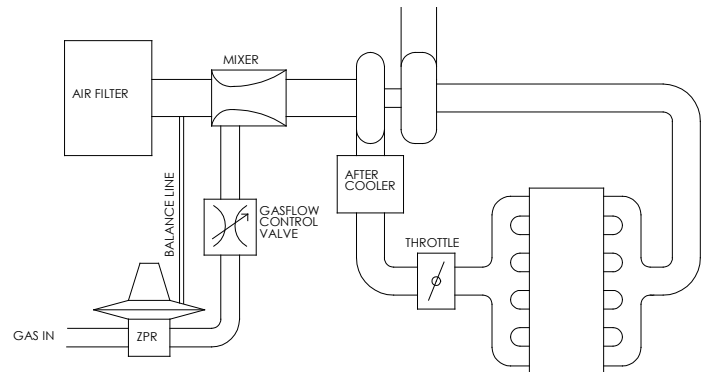
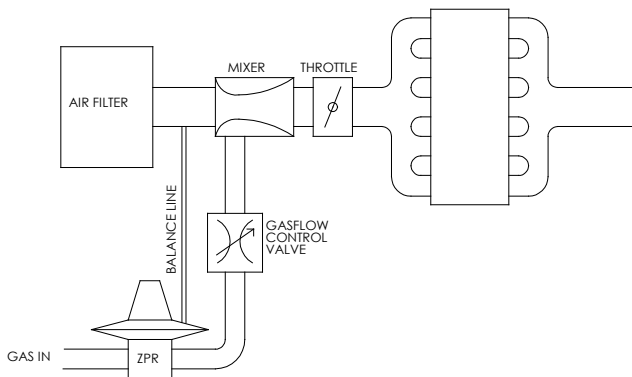

### Blow through turbo charged BTTC

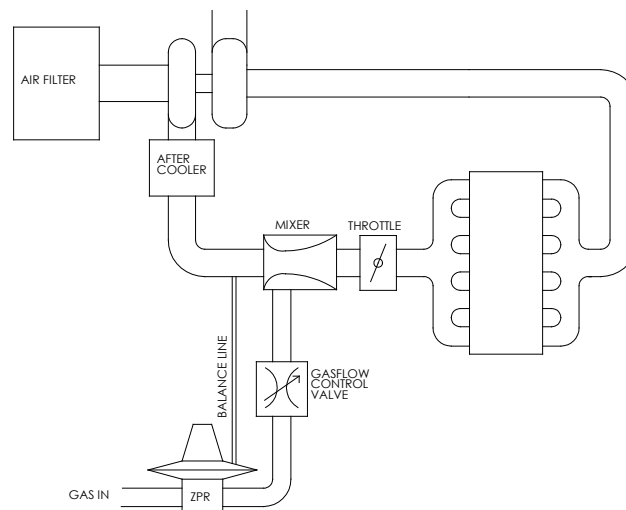

## SPEED CONTROL SYSTEMS FOR GAS ENGINES

This sheet helps the HEINZMANN application engineers to calculate and advice the proper carburetion equipment for your gas engine application. Please fill in this form and do not hesitate to contact HEINZMANN in case of doubts or questions. For identical applications this procedure will not be required as HEINZMANN will inform you about part numbers, commissioning instructions and settings. Please use always the latest order form which you can download at:

<http://www.heinzmann.com/en/engine-and-turbine-management/system-components>

---

### CUSTOMER INFORMATION

**Company:**

**Division:**

**Contact person:**

**Customer-ID:**

**Date:**

**Email:**

**Fax:**

**Phone:**

**Address:**

---

### ENGINE DATA

**Engine type:**

**Configuration:**

In-line engine

V-engine

**Turbo charger:**

Yes

No

**Max. boost pressure:**

bar abs.

**Engine displacement:**

liter

**No. of cylinders:**

**Vol. eff. (Ve):**

**Rated power:**

kW

**n<sub>start</sub>:**

rpm

**n<sub>Nominal</sub>:**

rpm

**Mech. efficiency (η):**

**Max. manifold temp:**

°C

**λ desired:**

**No. of teeth at the starter ring:**

**Application:**

(net parallel / island mode)

---

### SYSTEM PROPERTIES

**Positoner:**

or

**Speed Governor:**

**Control system:**

analogue

digital

**Set point external:**

analogue

digital

via CAN (extra charge)

Protocol:

(CAN-Open, J1939...)

**Cable length from control unit / control cabinet to the engine:**

meter

**Cable length from actuator to pickup:**

meter

**Error lamp:**

required

not required

---

### THROTTLE VALVE

**Throttle valve:**

required

not required

**Mounting position:**

aspirated engine

**Turbo:**

before or

behind intercooler

**For V-engines:**

single valve

double valve

**Lever:**

required

not required

**Connection with actuator:**

direct (not available for all sizes)

with rod system

---

## **GENERAL**

<b>Enquiry for the following volume:</b>	1-5 items	
<b>Number of items within a year:</b>		
<b>Communication program DcDesk 2000:</b>	required	not required
<b>Commissioning:</b>	required	not required
<b>Training course:</b>	required	not required
<b>Governmental requirements / certificates:</b>		

---