



Heinzmann GmbH & Co. KG
Engine & Turbine Controls

Am Haselbach 1
D-79677 Schönau (Schwarzwald)
Germany





Phone +49 7673 8208-0
Fax +49 7673 8208-188
E-mail info@heinzmann.com
www.heinzmann.com



V.A.T. No.: DE145551926

HEINZMANN®
Electronic Speed Governors

**Single-Phase Synchronizing
and
Load Sharing Unit**

AT 10-01

 Warning	<p>Read this entire manual and all other publications appertaining to the work to be performed before installing, operating or servicing your equipment.</p> <p>Practice all plant and safety instructions and precautions.</p>
 Danger	<p>Failure to follow instructions may result in personal injury and/or damage to property.</p> <p>HEINZMANN will refuse all liability for injury or damage which results from not following instructions</p>
 Danger! High Voltage  Danger	<p>Please note before commissioning the installation:</p> <p>Before starting to install any equipment, the installation must have been switched dead!</p> <p>Be sure to use cable shieldings and power supply connections meeting the requirements of the <i>European Directive concerning EMI</i>.</p> <p>Check the functionality of the existing protection and monitoring systems.</p>
 Danger	<p>To prevent damages to the equipment and personal injuries, it is imperative that the following monitoring and protection systems have been installed:</p> <p>Overspeed protection acting independently of the speed governor</p> <p>Overtemperature protection</p> <p>HEINZMANN will refuse all liability for damage which results from missing or insufficiently working overspeed protection</p> <p>Generator installation will in addition require:</p> <p>Overcurrent protection</p> <p>Protection against faulty synchronization due to excessive frequency, voltage or phase differences</p> <p>Reverse power protection</p>
	<p>Overspeeding can be caused by:</p> <p>Failure of the voltage supply</p> <p>Failure of the actuator, the control unit or of any accessory device</p> <p>Sluggish and blocking linkage</p>

 Warning	<p>The examples, data and any other information in this manual are intended exclusively as instruction aids and should not be used in any particular application without independent testing and verification by the person making the application.</p>
 Danger	<p>Independent testing and verification are especially important in any application in which malfunction might result in personal injury or damage to property.</p>
	<p>HEINZMANN make no warranties, express or implied, that the examples, data, or other information in this volume are free of error, that they are consistent with industry standards, or that they will meet the requirements for any particular application.</p>
	<p>HEINZMANN expressly disclaim the implied warranties of merchantability and of fitness for any particular purpose, even if HEINZMANN have been advised of a particular purpose and even if a particular purpose is indicated in the manual.</p>
	<p>HEINZMANN also disclaim all liability for direct, indirect, incidental or consequential damages that result from any use of the examples, data, or other information contained in this manual.</p>
	<p>HEINZMANN make no warranties for the conception and engineering of the technical installation as a whole. This is the responsibility of the user and of his planning staff and specialists. It is also their responsibility to verify whether the performance features of our devices will meet the intended purposes. The user is also responsible for correct commissioning of the total installation.</p>

Contents

	Page
1 Safety Instructions and Related Symbols.....	1
1.1 Basic Safety Measures for Normal Operation	2
1.2 Basic Safety Measures for Servicing and Maintenance	2
1.3 Before Putting an Installation into Service after Maintenance and Repair Works.....	3
2 Application.....	4
3 Functional Block Diagram.....	5
4 Operating Mode.....	6
4.1 A Connection to Electronic Speed Governors.....	6
4.2 Synchronizing	7
4.3 Load Sharing	7
5 Technical Data	8
6 Electric Connection	9
6.1 Table of Terminal Connections and their Functionality.....	9
6.2 External Latch of Generator Breaker and Auxiliary Contact for Load Sharing.....	10
6.3 Connection to Control Units of the E 1 - F and E 2 - F Series	11
6.4 Connection to Control Units of the E 6 to E 40 Series.....	11
6.5 Connection to Control Unit of the E 2000 Series.....	12
6.6 Connection to Digital Control Unit of the HELENOS Series	12
6.7 Connection to Digital Control Unit of the Serie PRIAMOS Series	13
6.8 Connection to Digital Control Unit of the PANDAROS Series.....	14
6.9 Connection of the Load Sharing Lines Among Several AT 10-01 Units.....	14
7 Dimensional Drawing.....	15
8 Commissioning	16
8.1 Meaning and Positions of the Adjustment Potentiometers, LEDs and Test Points.....	16
8.2 General Preparations Work for Commissioning	18
8.3 Initial Setting of the Electronic Speed Governor	19
8.4 Adjustment of Synchronizer Device	20
8.5 Normalizing the kW-Sensor / Adjustment in Isolated Parallel Operation	20
9 Connecting of Non-HEINZMANN Electronic Speed Governors	22
10 Systematic Trouble Shooting.....	23
10.1 Checking Engine Idling	23

10.2 Load Test of Individual Gensets.....	23
10.3 Checking Synchronizing Behaviour.....	24
10.4 Testing Automatic Load Sharing.....	24
10.5 Symptoms and Possible Causes.....	25
11 Ordering Specifications	26
12 Overall Connection Plans	27
13 Index of Figures.....	29
14 Order Specifications for Manuals.....	30

1 Safety Instructions and Related Symbols

This publication offers wherever necessary practical safety instructions to indicate inevitable residual risks when operating the engine. These residual risks imply dangers to

persons

product and engine

environment.

The symbols used in this publication are in the first place intended to direct your attention to the safety instructions!



Warning

This symbol is to indicate that there may exist dangers to the engine, to the material and to the environment.



Danger

This symbol is to indicate that there may exist dangers to persons. (Danger to life, personal injury)



Danger!
High
Voltage

This symbol is to indicate that there exist particular dangers due to electrical high tension. (Mortal danger).



Note

This symbol does not refer to any safety instructions but offers important notes for better understanding the functions that are being discussed. They should by all means be observed and practised. The respective text is printed in italics.

The primary issue of these safety instructions is to prevent personal injuries!

Whenever some safety instruction is preceded by a warning triangle labelled “Danger” this is to indicate that it is not possible to definitely exclude the presence of danger to persons, engine, material and/or environment.

If, however, some safety instruction is preceded by the warning triangle labelled “Caution” this will indicate that danger of life or personal injury is not involved.

The symbols used in the text do not supersede the safety instructions. So please do not skip the respective texts but read them thoroughly!

In this publication the Table of Contents is preceded by diverse instructions that among other things serve to ensure safety of operation. It is absolutely imperative that these hints be read and understood before commissioning or servicing the installation.v

1.1 Basic Safety Measures for Normal Operation

- The installation may be operated only by authorized persons who have been duly trained and who are fully acquainted with the operating instructions so that they are capable of working in accordance with them.
- Before turning the installation on please verify and make sure that
 - only authorized persons are present within the working range of the engine;
 - nobody will be in danger of suffering injuries by starting the engine.
- Before starting the engine always check the installation for visible damages and make sure it is not put into operation unless it is in perfect condition. On detecting any faults please inform your superior immediately!
- Before starting the engine remove any unnecessary material and/or objects from the working range of the installation/engine.
- Before starting the engine check and make sure that all safety devices are working properly!

1.2 Basic Safety Measures for Servicing and Maintenance

- Before performing any maintenance or repair work make sure the working area of the engine has been closed to unauthorized persons. Put on a sign warning that maintenance or repair work is being done.
- Before performing any maintenance or repair work switch off the master switch of the power supply and secure it by a padlock! The key must be kept by the person performing the maintenance and repair works.
- Before performing any maintenance and repair work make sure that all parts of engine to be touched have cooled down to ambient temperature and are dead!
- Refasten loose connections!
- Replace any damaged lines and/or cables without delay!

- Keep the cabinet always closed. Access should be permitted only to authorized persons having a key or tools.
- Never use a water hose to clean cabinets or other casings of electric equipment!

1.3 Before Putting an Installation into Service after Maintenance and Repair Works

- Check on all slackened screw connections to have been tightened again.
- Make sure the control linkage has been reattached and all cables have been reconnected.
- Make sure all safety devices of the installation are in perfect order and are working properly!

2 Application

The HEINZMANN single-phase synchronizing and load sharing unit AT 10-01 is conceived for automatic synchronization as well as isochronous resistive load sharing (without droop) of several parallelized generator sets in isolated operation.

In conjunction with various HEINZMANN electronic controls this multi-device is capable of performing the following functions:

- automatic synchronization
- isochronous resistive load sharing (droop zero)
- reverse power alarm

The synchronizing unit performs readjustment of frequency and phase position via a control unit superordinate of the speed governor, and will generate an impulse for closing the generator breaker via a relay switching output as soon as synchronization is achieved. This impulse must be made to be self-holding by an external circuit; likewise the procedure of opening the breaker to disconnect the genset again will have to be implemented externally.

The load sharing device consists of two functional modules, the kW sensor and the load sharing unit.

Resistive load sharing of all participating generators is generally performed by equal percentage independently of the maximum power outputs of the individual gensets.

If, for example, a 40 kW set and a 60 kW set have been parallelized, the first set will produce 20 kW in case of half load and the second 30 kW, i.e. 50% each.

3 Functional Block Diagram

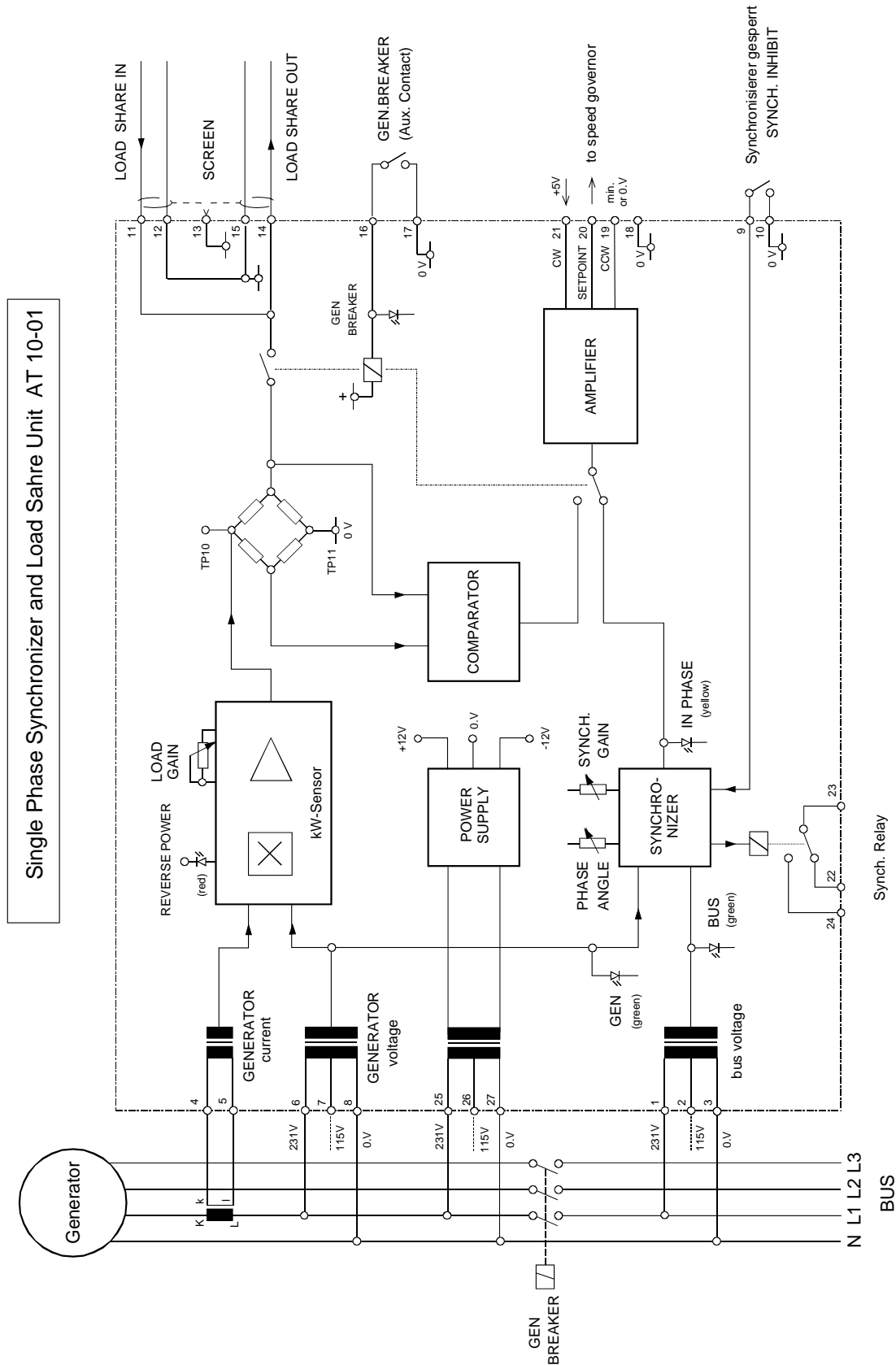

Figure 1: Functional Block Diagram AT 10-01

4 Operating Mode

The operation panel (see Fig. 2) makes a symbolical distinction the various functional blocks together with their operation and indication elements by separating lines:

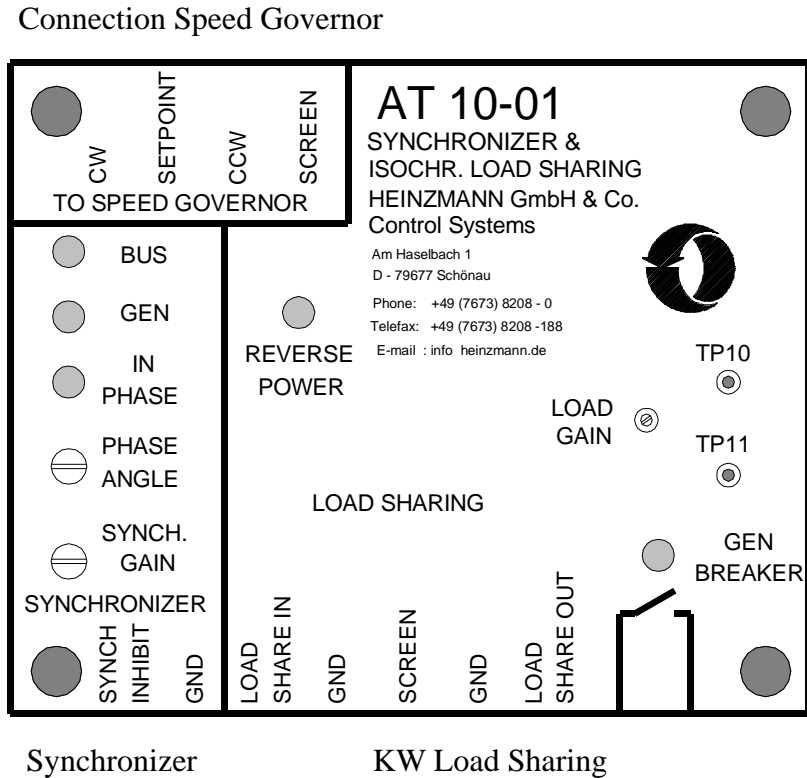

Figure 2: Operation Panel

4.1 A Connection to Electronic Speed Governors

+5 V auxiliary voltage is drawn from the speed governor and connected to terminal 21 (CW) of the AT 10. The setpoint signal inclusive of synchronization balancing or respectively load dependent offset signal is transmitted from terminal 20 (AT 10) to the speed governor. If the analogue speed governors E 6 – E 40 or E 2000 respectively are being used, the CCW connection (terminal 19 of AT 10) is connected to the base of the speed governor. With digital speed governors a 0 V connection must be conducted from the speed governor to terminal 19 of the AT 10 (**see also section 6!**).

4.2 Synchronizing

A PI control superordinate of the speed governor will condition frequency and phase alignment of the generator until it is operating synchronously to the active BUS (or centre bus bar). This condition is indicated by a yellow LED “IN PHASE”. By means of the two potentiometers “PHASE ANGLE” and “SYNCH. GAIN”, the working angle of the phase alignment and the control sensitivity and adjustment time of the synchronizing procedure can be optimized.

In synchronous condition, a pulse of about 1 sec is output via a relay switching output which will close the generator breaker. The user will have to implement both an external self-holding circuit and an additional external switch for opening the breaker.

4.3 Load Sharing

The single-phase kW-sensor converts by multiplication the current and voltage phase signals into DC voltages proportional to kW power. Any occurring reverse power is indicated by a red light emitting diode **REVERSE POWER**. In case this LED lights up during first commissioning the connection lines from installation current transformer of the installation to the input terminals of the AT 10-01 must be corrected.

(see Functional Block Diagram).



Danger!
High
Voltage

Prior to this intervention the installation must be shut down and switched dead!

The load proportional DC voltage is to be measured at the internal pins **TP 10** (signal) and **TP 11** (0 V) using a multimeter and to be normalized to **+6V** at 100% generator output using the potentiometer **LOAD GAIN**.

In parallel operation of several generators the load sharing lines of the AT 10-01 are connected with each other. On switching another genset onto an installation already operating on load a balancing current will be flowing in the load sharing lines until all active participants are loaded by equal percentages.

5 Technical Data

Voltage supply	115/230 V AC \pm 15%
<u>Signal Inputs:</u>	
Voltage	230/400 V AC \pm 15%
	or 115/200 V AC \pm 15%
Current	0 t 5 A per phase max. 2 VA (standard)
	or 0 to 1 A per phase max. 2 VA (optional)
Load measuring	U x I x cosϕ with one phase
Normalization of kW level	6 V DC at 100% generator output between TP 10 & TP 11
Level on load sharing line	0 - 3 V DC
Accuracy	\pm 3% at 100% generator output
Synchronization relay	pulse of approx. 1 sec.
Contact load	max. 8 A at 250 V AC max. 0,5 A at 24 V DC
Reverse power indication	by red LED
Temperature range	-40° C to +70° C
Protection grade	IP 00
Weight	approx. 0.5 kg

6 Electric Connection

6.1 Table of Terminal Connections and their Functionality

Terminal	Function
1	Voltage measuring input phase L1, with 231 V AC BUS
2	Voltage measuring input phase L1, with 115 V AC BUS
3	N BUS
4	Current measuring input L1, terminal k of current transformer
5	Current measuring input L1, terminal l of current transformer
6	Voltage measuring input phase L1, with 231 V AC Generator
7	Voltage sensing input phase L1, with 115 V AC Generator
8	N Generator
9	Synch. Inhibit , Bridge between 9 & 10 inhibits synchronization
10	GND = 0.V
11	Load share in , Input load sharing line
12	GND = 0.V
13	Screen = Connection of screen
14	GND = 0.V
15	Load share out , Output load sharing line
16	GEN BREAKER , Auxiliary contact breaker closed
17	GND = 0.V
18	Screen = Connection of screen
19	CCW = min. or 0 V connection from setpoint input of speed governor
20	SETPOINT = Output for current speed setpoint to speed governor
21	CW = +5V connection from speed governor
22	NC = Contact of synchronizer relay
23	COM = Root of synchronizer relay
24	NO = Closing contact of synchronizer relay (pulse)
25	231V AC Voltage supply
26	115V AC Voltage supply
27	N Voltage supply

6.2 External Latch of Generator Breaker and Auxiliary Contact for Load Sharing

As can be seen from the below figure, switching a genset onto the load sharing line is executed automatically on closing the generator breaker. By this, any inactive set will always remain disconnected from the load sharing line.

External latch and auxiliary contacts for connection to load share line

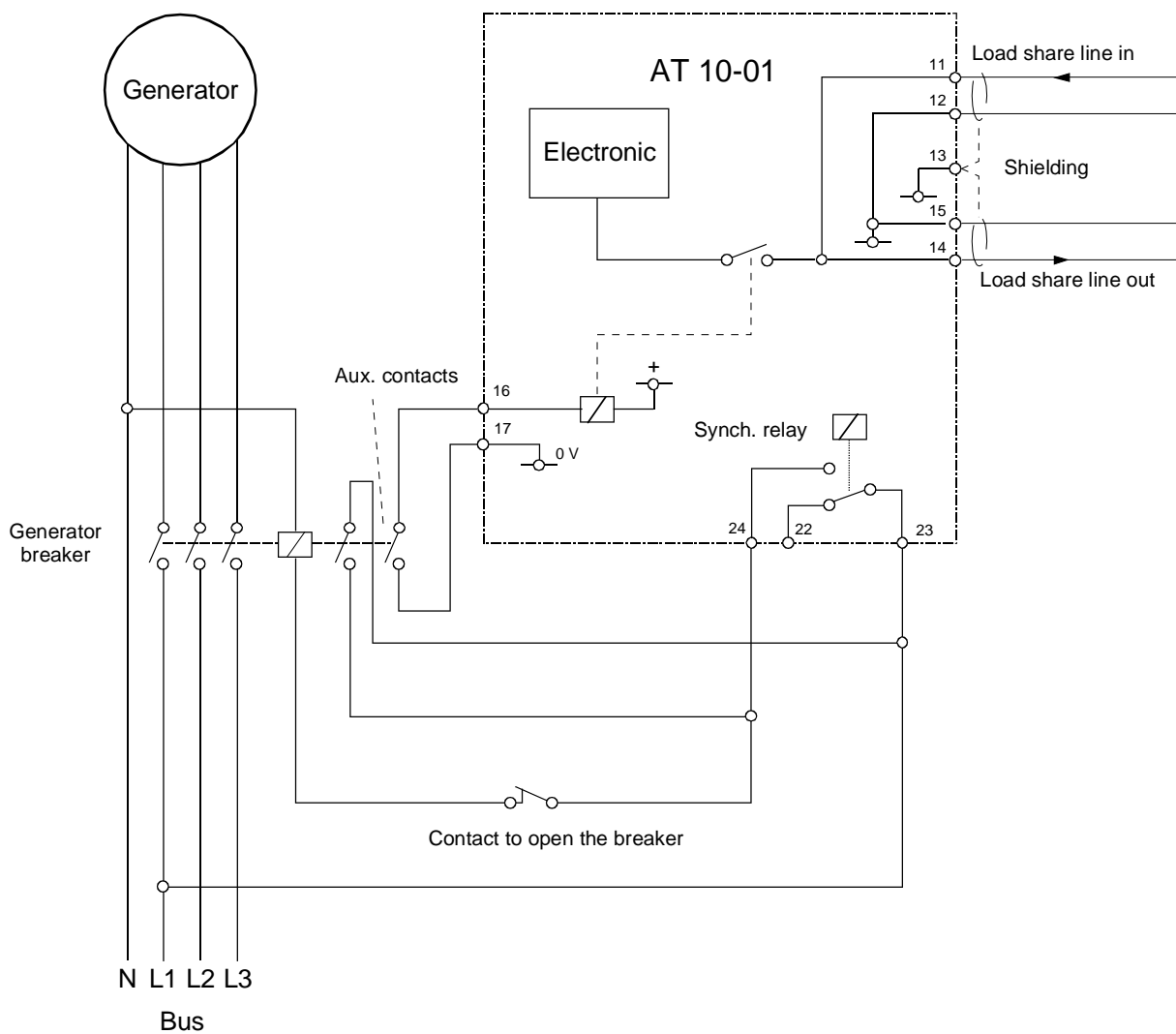

Figure 3: Auxiliary Contacts from Generator Breaker

6.3 Connection to Control Units of the E 1 - F and E 2 - F Series

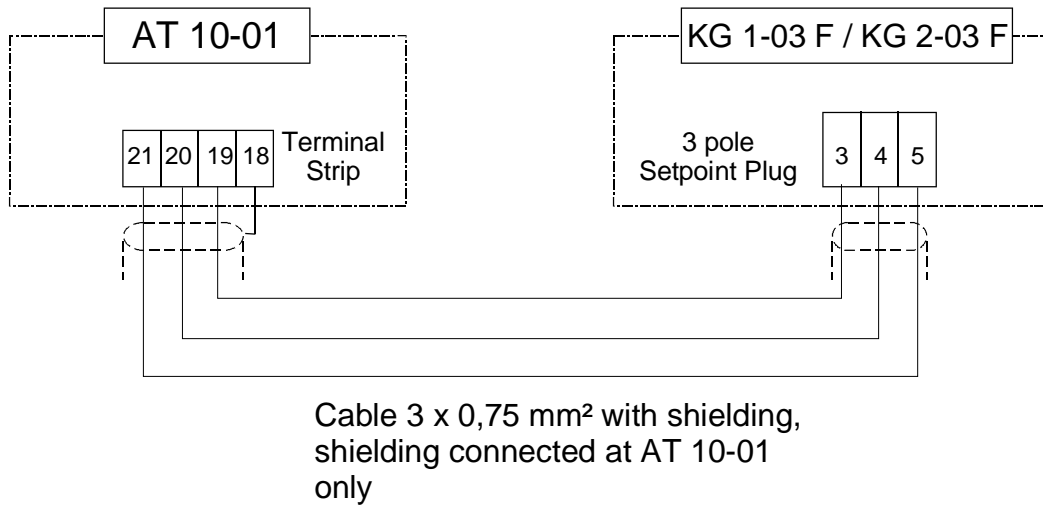

Figure 4: Cabling with Control Units of the E 1 - F and E 2 - F Series

6.4 Connection to Control Units of the E 6 to E 40 Series

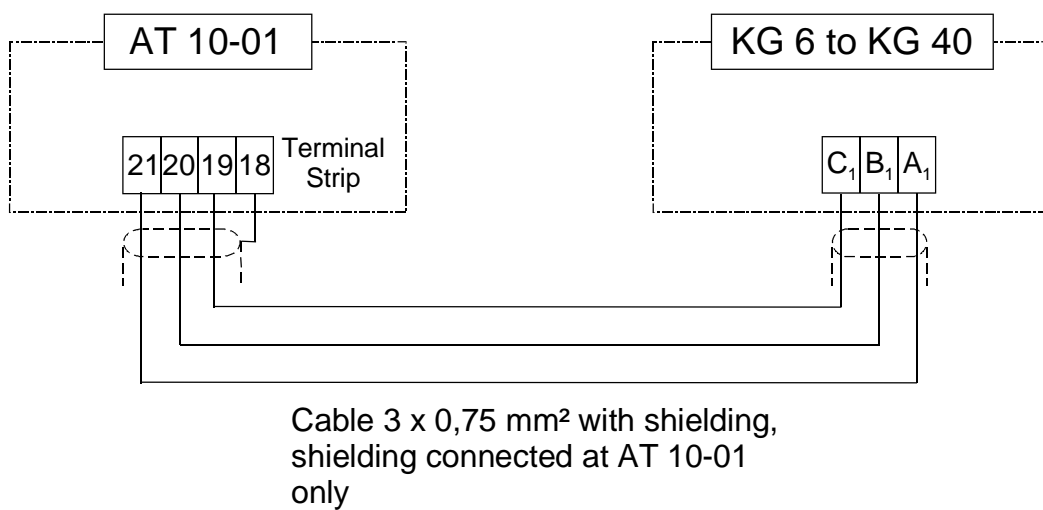

Figure 5: Cabling with Control Units of the Series E 6 to E 40

6.5 Connection to Control Unit of the E 2000 Series

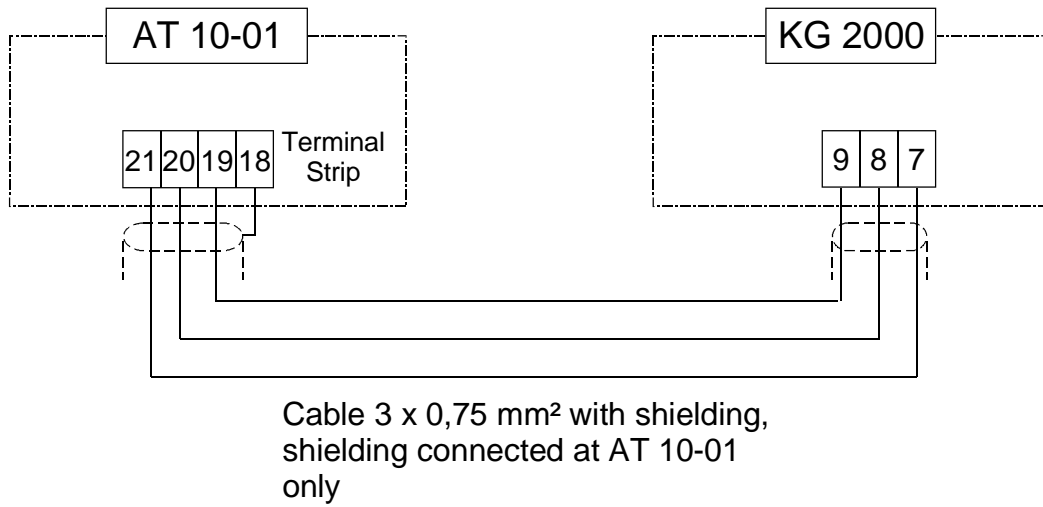

Figure 6: Cabling with Control Units of the E 2000 Series

6.6 Connection to Digital Control Unit of the HELENOS Series

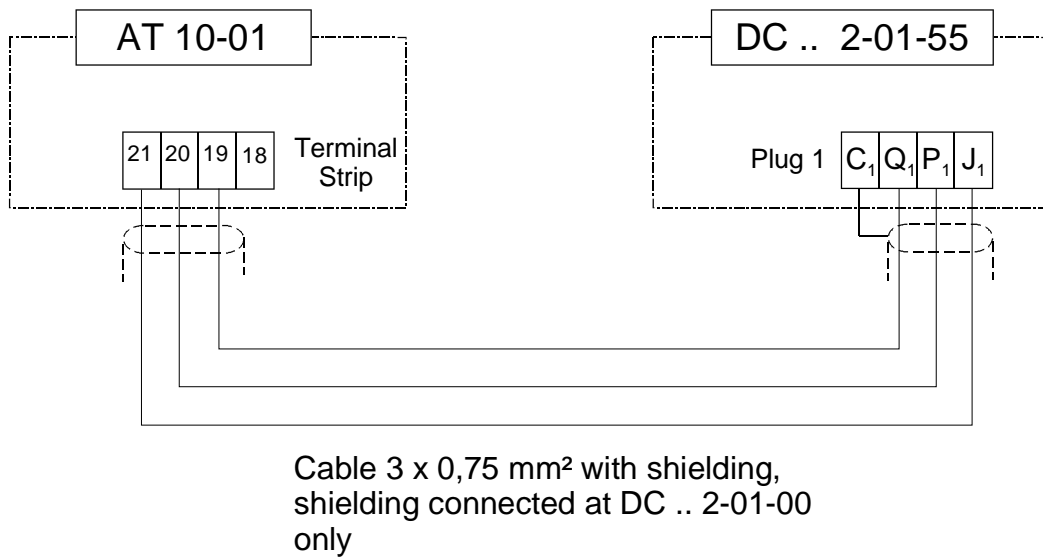
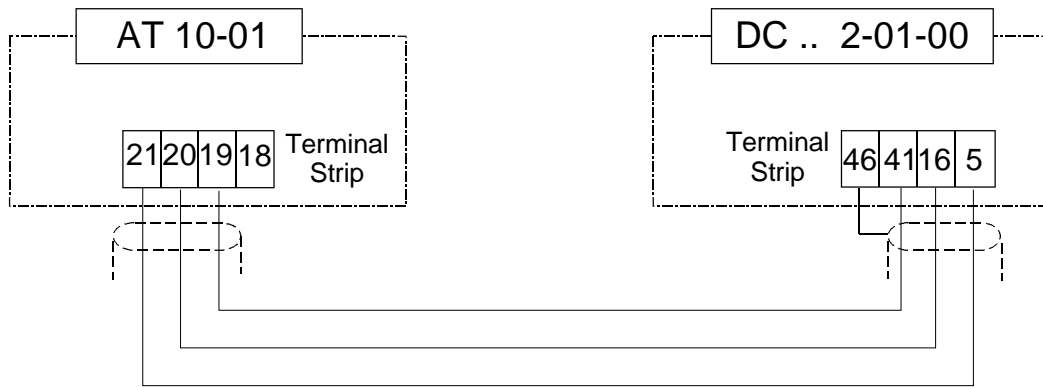

Figure 7: Cabling with Control Units of the HELENOS Series for Protection Grade IP 55



Cable 3 x 0,75 mm² with shielding,
shielding connected at DC .. 2-01-00
only

Figure 8: Cabling with Control Units of the HELENOS Series for Protection Grade IP 00

6.7 Connection to Digital Control Unit of the Serie PRIAMOS Series

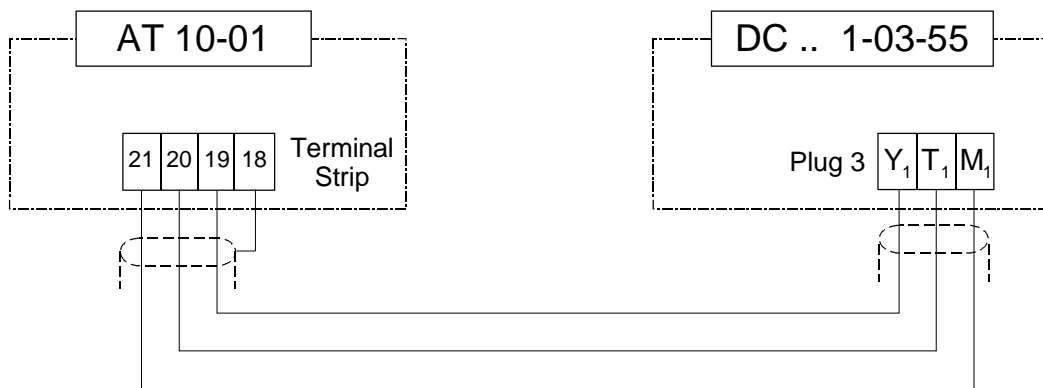

Cable 3 x 0,75 mm² with shielding,
shielding connected at AT 10-01
only

Figure 9: Cabling with Control Unit of the PRIAMOS Series

6.8 Connection to Digital Control Unit of the PANDAROS Series

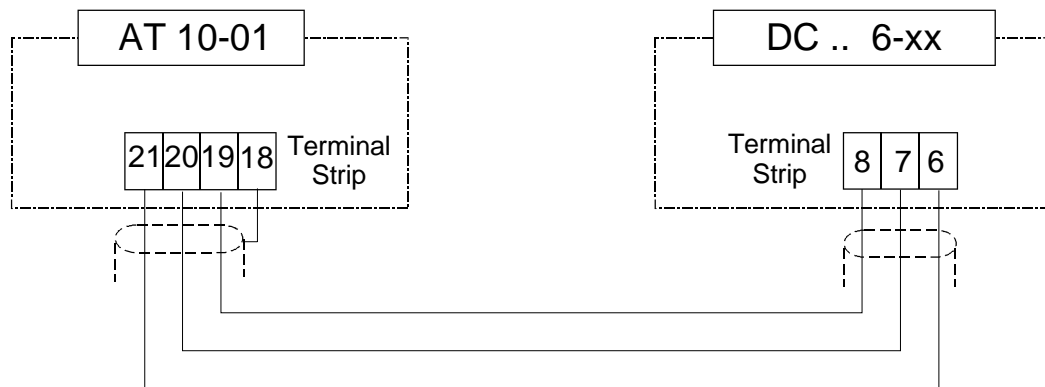

Cable 3 x 0,75 mm² with shielding,
shielding connected at AT 10-01
only

Figure 10: Cabling with Control Units of the PANDAROS Series

6.9 Connection of the Load Sharing Lines Among Several AT 10-01 Units

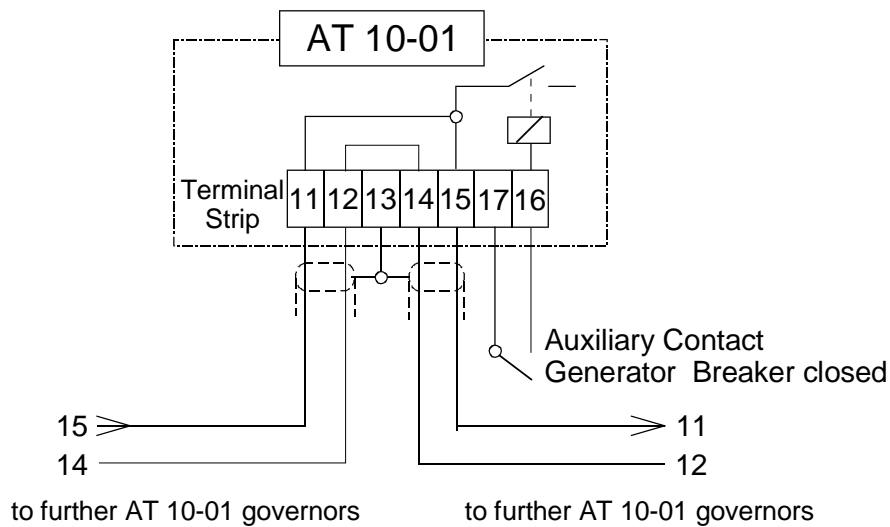

Figure 11: Connection Among Several AT 10-01 Units

7 Dimensional Drawing

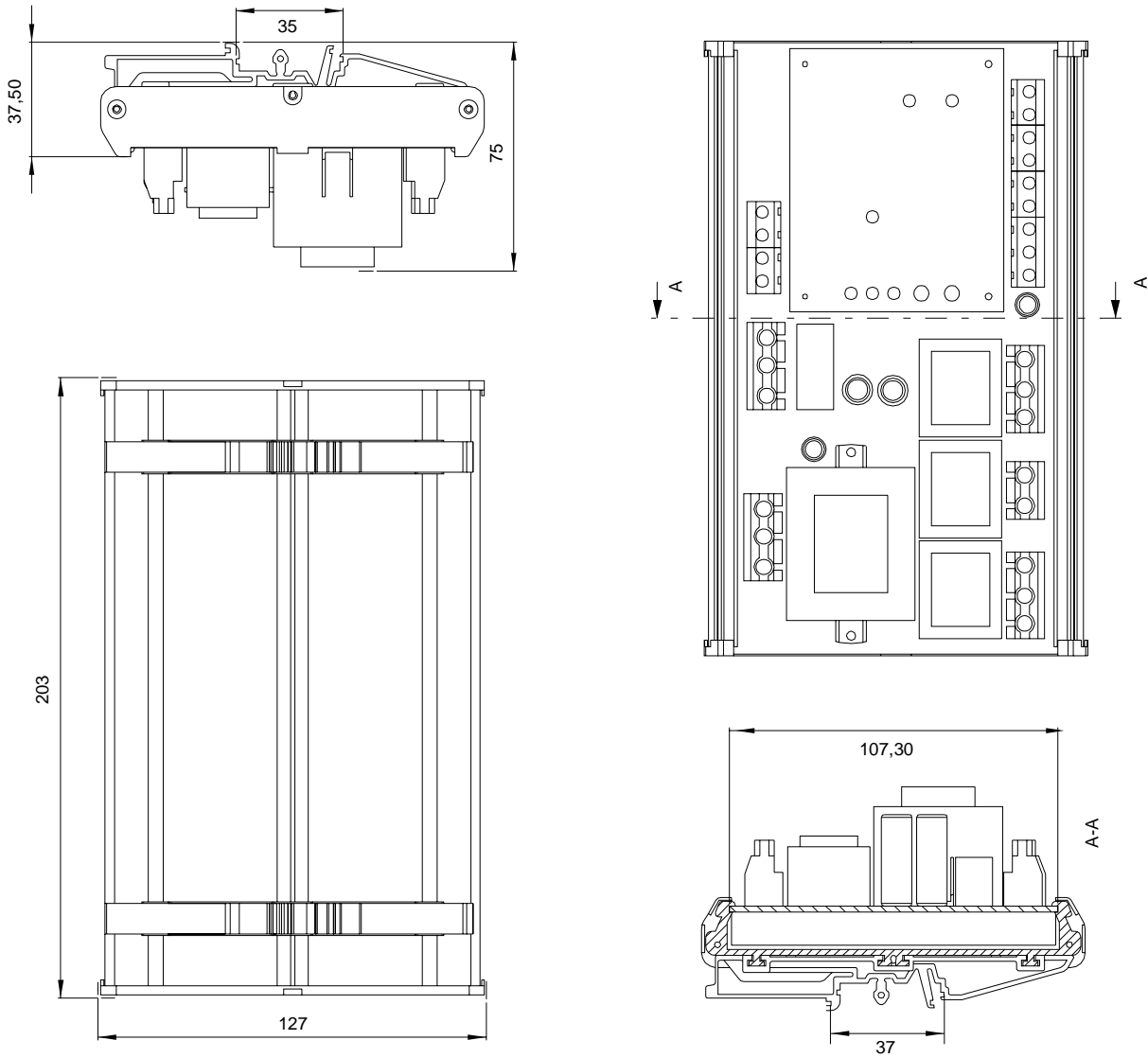

Figure 12: Dimensional Drawing AT 10-01

8 Commissioning

8.1 Meaning and Positions of the Adjustment Potentiometers, LEDs and Test Points

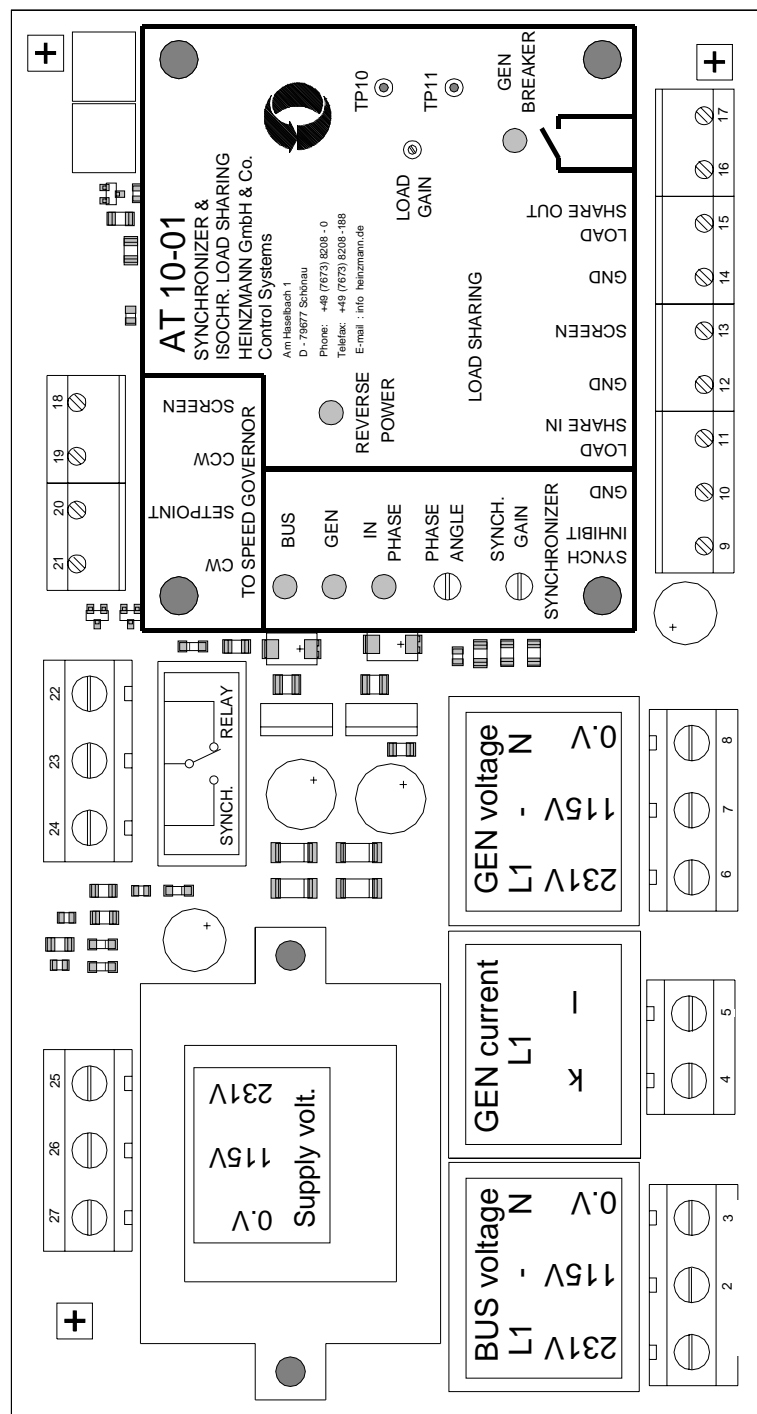

Figure 13: Positions of the Adjustment Potentiometers, LEDs and Test Points

LED	Colour	Function
Synchronizer:	-	-
BUS	green	Voltage on bus bar
GEN	green	Voltage from generator
IN PHASE	yellow	Generator in phase with bus bar
Load sharing:	-	-
GEN BREAKER	yellow	Generator breaker closed
REVERSE POWER	red	Reverse power

Potentiometer	Function
Synchronizer:	-
PHASE ANGLE	Working angle for phase difference Master - Slave
SYNCH GAIN	Sensitivity and adjustment time during synchronizing
Load sharing:	-
LOAD GAIN	Adjustment at 100% generator output: +6V DC at TP 10 - TP 11

Test points	Function
TP 10	Measurement of normalized voltage (at rated power + 6 V DC)
TP 11	0 V Reference point for measuring normalized voltage

8.2 General Preparations Work for Commissioning



Warning

Commissioning any generator installation may be conducted only by qualified personnel!

- 8.2.1.** Connect the measuring inputs for centre bus voltage, generator voltage and current transformer.



Warning

Particular care should be taken to ensure that identical voltage measuring phases of the centre bus and the generator are being used, e.g., that L1 and the current transformer is also measuring the L1-current from the generator!

- 8.2.2.** Connect the 230 V (or 115 V resp.) supply voltage for the AT 10-01. The electronic control is connected with the AT 10-01, and in case several AT10-01s are being used their load sharing lines are to be connected with each other.
- 8.2.3.** For activating load sharing, the potential free auxiliary contact of the generator breaker must be connected in accordance with Figure 3.
- 8.2.4.** De-activate the synchronizing utility (bridge between 9 & 10) and inhibit closing the generator breaker by disconnecting and insulating the cable from terminal 24.
- 8.2.5.** The auxiliary contact of the generator breaker (terminals 16 & 17) must be opened; in this condition the GEN – LED will be dark.

8.3 Initial Setting of the Electronic Speed Governor

For more detailed information on the initial setting of the speed governor being used, please refer to the respective publication.

- 8.3.1. Make sure that droop in the speed governor (control unit) has been set to zero.

- 8.3.2. Start the engine and run it up to rated speed. In doing so, generator frequency must be correctly set, e.g., to 50 Hz (or 60 Hz respectively). Analogue speed governors have an internal speed potentiometer, digital controls will have to be set to 50 Hz by means of the parameters Min. Speed and Max. Speed. Begin by setting Max. Speed to 1,560 rpm and adjust Min. Speed (approx. 1,250 rpm) until exactly 50 Hz are obtained.

- 8.3.3. Once the engine is warm, optimize **Gain**, **Stability** and **Derivative** in the control unit in order to obtain good idling stability as well as optimum dynamic behaviour on load changes.

8.4 Adjustment of Synchronizer Device

- 8.4.1.** Make sure that closing the generator breaker will continue to be inhibited, and activate the synchronizer device by removing the bridge 9 & 10 of the AT 10-01.
- 8.4.2.** Optimize synchronizing performance by means of the potentiometers **PHASE ANGLE** and **SYNCH. GAIN**.



Generator voltage must be adjusted by means of the generator's voltage regulator before enabling synchronization. The AT 10-01 will influence only frequency and phase position but not generator voltage.



Prior to adding the first set it must be checked in the course of a ready for operation synchronization whether the voltages across the open generator breaker are approximately 0 Volts on all 3 phases. This is to ensure that there will be no phase mismatch between the generator bus and centre bus. Attention, dangerous voltages!

- 8.4.3.** This done, the initial setting of the load control unit will have to be made.

8.5 Normalizing the kW-Sensor / Adjustment in Isolated Parallel Operation



There must no voltage be applied to the centre bus bar!

- 8.5.1.** Start one genset, switch it manually onto the bus bar and set it to 20% of rated load.
- 8.5.2.** Connect a voltmeter with a measuring range of 10 V DC to the test points T10 (signal) and TP11 (0 V). Voltages measured to be positive are proportional to generator power output. If the red reverse power diode REVERSE POWER lights up the cabling of the current transformer inputs must be checked and corrected. For this checking procedure, the engine must be stopped and the installation switched dead. When the correction has been made the LED will go out, and the measured voltage should increase in dependence of load.
- 8.5.3.** Increase generator power to 100% and set the potentiometer **LOAD GAIN** in such a way that there is a voltage of +6 V DC at TP10. If only 50% load is avail-

able, the voltage will have to be adjusted to half this value, viz. 3 V DC (0 V DC being equivalent to 0% power).



Note

If +6 V cannot be obtained at 100% power the following errors may have occurred:

- 1) Input voltage is low, e.g., voltage between phase and N is but 100 V instead of 230 V.*
- 2) Input current is low, e.g., 2.5 A instead of 5 A at rated power due to a wrongly configured current transformer within the installation.*
- 3) Wrong assignment of current input to voltage input.*

8.5.6. Start genset 1, switch it manually onto the centre bus and load the set by 50% rated power.

8.5.7. Remove all blockings of the generator breakers of all gensets one after another.

8.5.8. Start the second genset which has also been preadjusted and synchronize it to the first one. The second genset should now take over half the load.

8.5.9. Increase load to 100%. If there should be differences of load shares, this can be corrected by slightly readjusting the potentiometer **LOAD GAIN**.

8.5.10. Decrease load to 0%. If there should be load differences at no-load, this will indicate that there exist speed differences in governor adjustment. This fault can be eliminated by readjusting the speed setpoint of one genset.

8.5.11. Now, several gensets can be parallelized. If the preceding adjustments have been accurately made load sharing should now be satisfactory.

Generally: Any differences at no-load are to be corrected via the speed setpoints of the speed governors, and any differences at full-load are to be corrected by means of the potentiometers **LOAD GAIN** of the AT 10-01.

9 Connecting of Non-HEINZMANN Electronic Speed Governors

Basically all electronic speed governors can operate together with the AT 10-01, as long as they meet the following requirements:

- 1.) 3 terminals must be available:
 - setpoint input (0-5 V)
 - auxiliary voltage (approx. +5 V)
 - 0 V

- 2.) Increasing the external setpoint voltage must increase the engine speed.

10 Systematic Trouble Shooting

In the event of any failure, refrain from changing the settings of all of the adjustment potentiometers of the speed governor, the synchronizer or the load sharing unit in an uncontrolled way, as this is likely to additionally aggravate the existing problems.

Proceed systematically by the following steps instead.

Experience shows that in many cases the fault will not be caused by the electronic control but rather by the peripherals.

10.1 Checking Engine Idling

Engine check by means of the speed governor without affecting the synchronizing and load sharing devices. To do so, connect the terminals 9 & 10 (Synch. Inhibit) by a bridge and remove the cable from terminal 24 and isolate it (so that the generator breaker cannot close).

Now test whether the engine is running smoothly and without oscillations at idle speed and whether on shortly overriding the actuator manually it is being properly stabilized.

10.2 Load Test of Individual Gensets

The system may not be loaded before the engine is running properly at idle speed.

Start by isolated single operation if the installation allows of doing so. In the event that there occur overload symptoms at part-load check whether the external positioning lever of the actuator is at the 100% stop position. If this is the case, the engine is not producing enough power. Possible causes might be these:

Gas engines:	Gas supply, e.g., poor gas quality, particularly when operating by sewage gas and landfill gas spark plugs defective ignition system at fault
Diesel engines:	Cylinder failure due to defective injection nozzle Sluggishness or friction of linkage

10.3 Checking Synchronizing Behaviour

Start one genset and switch it manually onto the bus bar. After engine start, remove the bridge between the terminals 9 & 10 of the problematic genset (terminal 24 remains insulated to prevent actuating the generator breaker for the time being) and optimize the synchronizing unit by means of the potentiometers PHASE ANGLE and SYNCH. GAIN. Usually the plant will have a synchronoscope installed you can use to check the system for optimum functionality.

Abort the synchronizing procedure by shortly bridging the terminals 9 & 10 thus forcing the synchronizer unit to start again from the beginning. It is only when the synchronizing procedure is taking a normal course that the connection cable for actuating the generator breaker may be connected to terminal 24.



Danger!
High
Voltage

This work must by all means be done in zero potential condition since depending on the type of breaker installed in the plant 230V may be being applied.

10.4 Testing Automatic Load Sharing

Check load sharing among at least two gensets operating in parallel at minimum and maximum generator load, and readjust if necessary.

10.5 Symptoms and Possible Causes

Symptoms	Possible causes
<p>Generator set does not share load with other sets or trips on reverse power</p>	<p>Wrong connection of the conducting lines of the load sharing lines</p> <p>Wrong adjustment of LOAD GAIN</p> <p>Wrong connection of the current transformers or the voltage inputs</p> <p>Wrong setting of engine speed at no-load</p> <p>No operating voltage to AT 10-01, or one measuring phase is missing</p>
<p>The set generator speed drops under load in isolated operation</p>	<p>Actuator at maximum stop position at part-load</p> <p>Auxiliary contact of generator breaker is not closed or is wrongly connected</p> <p>Speed governor is set to droop mode</p> <p>Short circuit in load sharing lines</p>
<p>Unequal load sharing</p>	<p>In high load range: Check LOAD GAIN setting of AT 10-01</p> <p>In low load range: Check speed setting of governor at no-load</p>

11 Ordering Specifications

The ordering specification is: AT 10-01

In addition the following specifications are required:

Generator voltage 230/400 V or 115/200 V

Current transformer 5 A or 1 A at nominal load

Governor type which Heinzmann Electronic Control is being used?

When there are no specifications by the user, the AT 10-01 will by standard be shipped as follows:

Generator voltage 230 V (phase-N) or 400 V (phase-to-phase)

Current transformer 5 A at nominal load

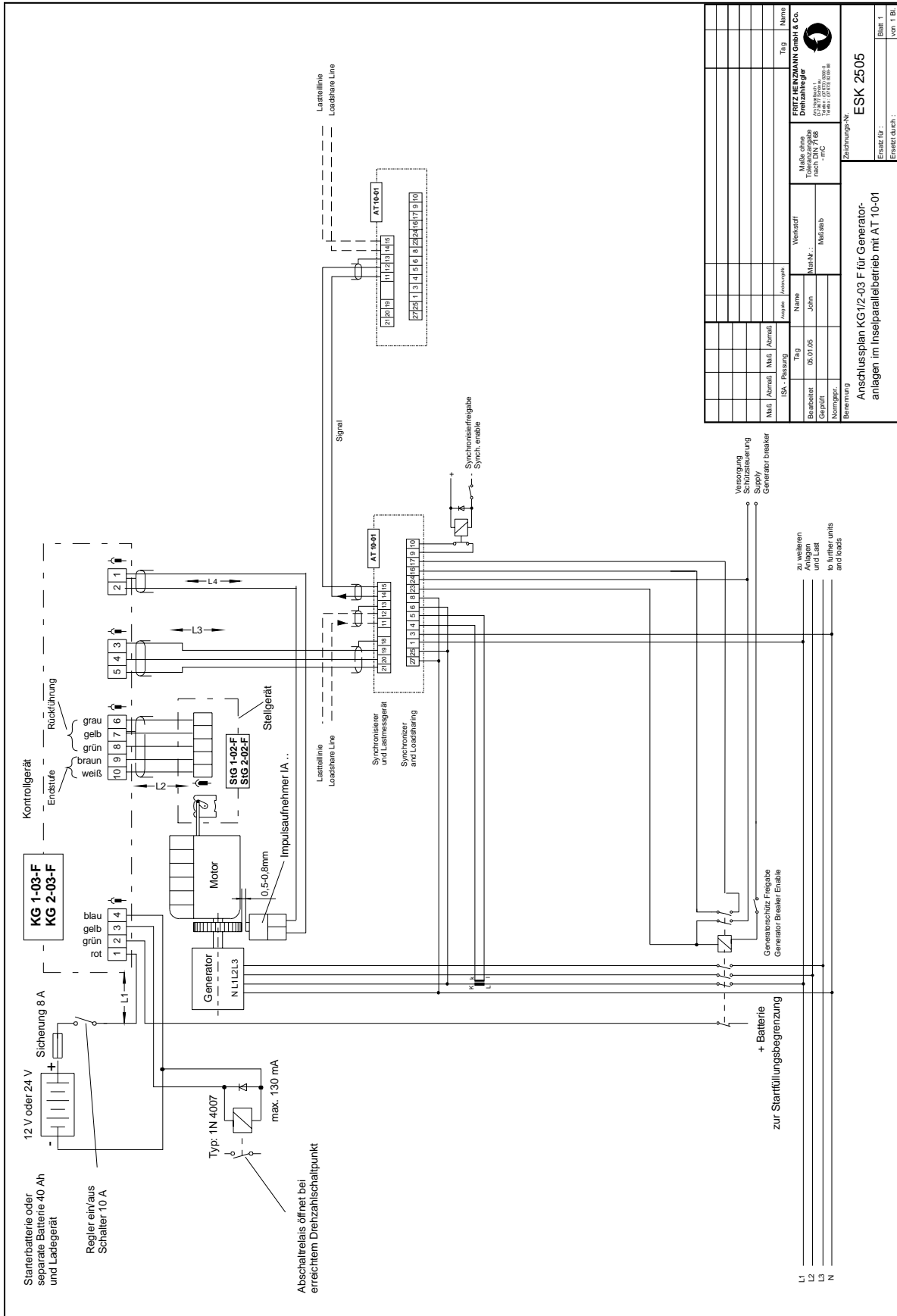

Name		Tag	
Name		Tag	
Abm. / Abmaß		Abm. / Abmaß	
ISA - Passung		ISA - Passung	
Hersteller		Hersteller	
Geprüft		Geprüft	
Normgezt.		Normgezt.	
Bewertung		Bewertung	
Anschlussschema		Anschlussschema	
Name		Name	
Abm. / Abmaß		Abm. / Abmaß	
Toleranzangabe nach DIN 7168		Toleranzangabe nach DIN 7168	
Material		Material	
Werkstoff		Werkstoff	
FRTZ HEINZMANN GmbH & Co.		FRTZ HEINZMANN GmbH & Co.	
Ersatz Nr.:		Ersatz Nr.:	
Ersatz durch:		Ersatz durch:	
Blatt 1		Blatt 1	
von 1 Bl.		von 1 Bl.	

Figure 15: Connection Plan for KG 1/2-03-F with AT 10-01 in Isolated Parallel Operation

13 Index of Figures

Figure 1: Functional Block Diagram AT 10-01	5
Figure 2: Operation Panel	6
Figure 3: Auxiliary Contacts from Generator Breaker.....	10
Figure 4: Cabling with Control Units of the E 1 - F and E 2 - F Series.....	11
Figure 5: Cabling with Control Units of the Series E 6 to E 40.....	11
Figure 6: Cabling with Control Units of the E 2000 Series	12
Figure 7: Cabling with Control Units of the HELENOS Series for Protection Grade IP 55 ...	12
Figure 8: Cabling with Control Units of the HELENOS Series for Protection Grade IP 00 ...	13
Figure 9: Cabling with Control Unit of the PRIAMOS Series	13
Figure 10: Cabling with Control Units of the PANDAROS Series	14
Figure 11: Connection Among Several AT 10-01 Units.....	14
Figure 12: Dimensional Drawing AT 10-01	15
Figure 13: Positions of the Adjustment Potentiometers, LEDs and Test Points.....	16
Figure 14: Connection Plan for KG 6..40 and KG 2000 with AT 10-01 in Isolated Parallel Operation.....	27
Figure 15: Connection Plan for KG 1/2-03-F with AT 10-01 in Isolated Parallel Operation..	28

14 Order Specifications for Manuals

There is no charge for our technical manuals ordered in reasonable quantities.

Order the necessary manuals on our speed governors from your nearest

[HEINZMANN location](#).

(Please click on “HEINZMANN location” to see the list of our subsidiaries and agents in the world).

Please include the following information:

- your name,
- the name and address of your company (you can simply include your business card),
- the address where you want the manuals sent (if different from above),
- the number(s) (as on front page bottom right) and title(s) of the desired manual(s),
- or the technical data of your **HEINZMANN** equipment,
- the quantity you want.

You can directly use the following fax-form for ordering one or several manuals.

Most of the manuals are available as acrobat PDF-files, too. On request they can be send via e-mail.

We solicit comments about the content and the presentation of our publications. Please, send your comments to:

HEINZMANN GmbH & Co. KG

Service Department

Am Haselbach 1

D-79677 Schönau

Germany

Fax Reply

Order for HEINZMANN technical manuals

Fax-Hotline +49 7673 8208 194

Please send me the following manuals:

Quantity	No. of the manual	Title

Please send me your new sales documentation about

() the HEINZMANN Analogue Governors Application:

() the HEINZMANN Digital Governors Application:

() the HEINZMANN Gas Engine Equipment Application:

Company

Contact Person.....

Department

Address..... Country/Code/Town.....

Phone..... Fax.....

E-Mail.....

Activity.....

Date