



**Heinzmann GmbH & Co. KG**  
**Engine & Turbine Controls**

Am Haselbach 1  
D-79677 Schönau (Schwarzwald)  
Germany

Phone +49 7673 8208-0  
Fax +49 7673 8208-188  
E-mail [info@heinzmann.com](mailto:info@heinzmann.com)  
[www.heinzmann.com](http://www.heinzmann.com)

V.A.T. No.: DE145551926

**HEINZMANN®**

Elektronic Speed Governors

## **Analogue Positioning Systems**





**JANUS**

**PS 6 up to PS 40**

**PS 2010 up to PS 2080**

**StG 16.90-03 up to StG 40.90-03**



 <p><b>Warning</b></p>	<p>Read this entire manual and all other publications appertaining to the work to be performed before installing, operating or servicing your equipment.</p> <p>Practice all plant and safety instructions and precautions.</p>
 <p><b>Danger</b></p>	<p>Failure to follow instructions may result in personal injury and/or damage to property.</p> <p>HEINZMANN will refuse all liability for injury or damage which results from not following instructions</p>
 <p><b>Danger! High Voltage</b></p>  <p><b>Danger</b></p>	<p><b>Please note before commissioning the installation:</b></p> <p>Before starting to install any equipment, the installation must have been switched dead!</p> <p>Be sure to use cable shieldings and power supply connections meeting the requirements of the <i>European Directive concerning EMI</i>.</p> <p>Check the functionality of the existing protection and monitoring systems.</p>
 <p><b>Danger</b></p>	<p><b>To prevent damages to the equipment and personal injuries, it is imperative that the following monitoring and protection systems have been installed:</b></p> <p>Overspeed protection acting independently of the speed governor</p> <p>Overtemperature protection</p> <p>HEINZMANN will refuse all liability for damage which results from missing or insufficiently working overspeed protection</p> <p><b>Generator installation will in addition require:</b></p> <p>Overcurrent protection</p> <p>Protection against faulty synchronization due to excessive frequency, voltage or phase differences</p> <p>Reverse power protection</p>
	<p><b>Overspeeding can be caused by:</b></p> <p>Failure of the voltage supply</p> <p>Failure of the actuator, the control unit or of any accessory device</p> <p>Sluggish and blocking linkage</p>



**Warning**

The examples, data and any other information in this manual are intended exclusively as instruction aids and should not be used in any particular application without independent testing and verification by the person making the application.



**Danger**

Independent testing and verification are especially important in any application in which malfunction might result in personal injury or damage to property.

**HEINZMANN** make no warranties, express or implied, that the examples, data, or other information in this volume are free of error, that they are consistent with industry standards, or that they will meet the requirements for any particular application.

**HEINZMANN** expressly disclaim the implied warranties of merchantability and of fitness for any particular purpose, even if **HEINZMANN** have been advised of a particular purpose and even if a particular purpose is indicated in the manual.

**HEINZMANN** also disclaim all liability for direct, indirect, incidental or consequential damages that result from any use of the examples, data, or other information contained in this manual.

**HEINZMANN** make no warranties for the conception and engineering of the technical installation as a whole. This is the responsibility of the user and of his planning staff and specialists. It is also their responsibility to verify whether the performance features of our devices will meet the intended purposes. The user is also responsible for correct commissioning of the total installation.

## Contents

	<b>Page</b>
<b>1 Safety Instructions and Related Symbols .....</b>	<b>1</b>
1.1 Basic Safety Measures for Normal Operation.....	2
1.2 Basic Safety Measures for Servicing and Maintenance .....	2
1.3 Before Putting an Installation into Service after Maintenance and Repair Works .....	3
<b>2 General .....</b>	<b>4</b>
<b>3 Functional Block Diagram .....</b>	<b>5</b>
<b>4 Operating Mode.....</b>	<b>6</b>
<b>5 Positioning Control Unit PKG .. - 04 - .. .....</b>	<b>7</b>
5.1 Specification .....	7
5.2 Versions .....	8
5.3 Measurements.....	9
<b>6 Actuators .....</b>	<b>11</b>
6.1 Design and Mode of Operation .....	11
6.1.1 Actuators StG 6-01 up to StG 40-01.....	11
6.1.2 Actuators StG 2010-01 up to 2080-01 .....	12
6.2 Installation .....	13
6.3 Specification .....	14
6.4 Measurements.....	19
<b>7 Regulating Linkage .....</b>	<b>25</b>
7.1 Length of Lever Arm.....	25
7.2 Connecting Linkage.....	25
7.3 Linkage Adjustment for Diesel Engines.....	26
7.4 Linkage Adjustment for Carburettor Engines .....	27
<b>8 Electrical Connection.....</b>	<b>28</b>
8.1 Wiring Diagram.....	28
8.2 Connection of Power Supply .....	29
<b>9 Adjustment.....</b>	<b>31</b>
9.1 Power Supply Indication .....	31
9.2 Selection Switches.....	32
9.3 Adjusting Output Signal .....	33
9.4 Adjusting Dynamics .....	33

9.5 Adjusting Input Signal.....	34
<b>10 Ordering Specifications .....</b>	<b>35</b>
<b>11 Special Application: Actuators with integrated Positioning Electronic.....</b>	<b>36</b>
11.1 General Specifications.....	36
11.2 Actuator Type dependent Specifications.....	37
11.3 Measurements.....	38
11.4 Wiring Diagram.....	39
11.5 Ordering Specifications .....	40
<b>12 Figure List.....</b>	<b>41</b>
<b>13 Order Specifications for Manuals.....</b>	<b>42</b>

## 1 Safety Instructions and Related Symbols

This publication offers wherever necessary practical safety instructions to indicate inevitable residual risks when operating the engine. These residual risks imply dangers to

persons

product and engine

environment.

The symbols used in this publication are in the first place intended to direct your attention to the safety instructions!



Warning

*This symbol is to indicate that there may exist dangers to the engine, to the material and to the environment.*



Danger

*This symbol is to indicate that there may exist dangers to persons. (Danger to life, personal injury))*



Danger!  
High  
Voltage

*This symbol is to indicate that there exist particular danger due to electrical high tension. (Mortal danger).*



Note

*This symbol does not refer to any safety instructions but offers important notes for better understanding the functions that are being discussed. They should by all means be observed and practiced. The respective text is printed in italics.*

**The primary issue of these safety instructions is to prevent personal injuries!**

Whenever some safety instruction is preceded by a warning triangle labelled “Danger” this is to indicate that it is not possible to definitely exclude the presence of danger to persons, engine, material and/or environment.

If, however, some safety instruction is preceded by the warning triangle labelled “Caution” this will indicate that danger of life or personal injury is not involved.

**The symbols used in the text do not supersede the safety instructions. So please do not skip the respective texts but read them thoroughly!**

**In this publication the Table of Contents is preceded by diverse instructions that among other things serve to ensure safety of operation. It is absolutely imperative that these hints be read and understood before commissioning or servicing the installation.**

### **1.1 Basic Safety Measures for Normal Operation**

- The installation may be operated only by authorized persons who have been duly trained and who are fully acquainted with the operating instructions so that they are capable of working in accordance with them.
- Before turning the installation on please verify and make sure that
  - only authorized persons are present within the working range of the engine;
  - nobody will be in danger of suffering injuries by starting the engine.
- Before starting the engine always check the installation for visible damages and make sure it is not put into operation unless it is in perfect condition. On detecting any faults please inform your superior immediately!
- Before starting the engine remove any unnecessary material and/or objects from the working range of the installation/engine.
- Before starting the engine check and make sure that all safety devices are working properly!

### **1.2 Basic Safety Measures for Servicing and Maintenance**

- Before performing any maintenance or repair work make sure the working area of the engine has been closed to unauthorized persons. Put on a sign warning that maintenance or repair work is being done.
- Before performing any maintenance or repair work switch off the master switch of the power supply and secure it by a padlock! The key must be kept by the person performing the maintenance and repair works.
- Before performing any maintenance and repair work make sure that all parts of engine to be touched have cooled down to ambient temperature and are dead!
- Refasten loose connections!
- Replace at once any damaged lines and/or cables!
- Keep the cabinet always closed. Access should be permitted only to authorized persons having a key or tools.

- Never use a water hose to clean cabinets or other casings of electric equipment!

### **1.3 Before Putting an Installation into Service after Maintenance and Repair Works**

- Check on all slackened screw connections to have been tightened again!
- Make sure the control linkage has been reattached and all cables have been reconnected.
- Make sure all safety devices of the installation are in perfect order and are working properly!

## 2 General

The **HEINZMANN** Positioning Systems are complements of the **HEINZMANN** Electronic Governors that have proved their efficiency and reliability in decades of service.

They can be used for a wide range of control applications or in combination with superior control systems for control purposes of any kind.

In positioning systems, there is a proportional correlation between the position of the actuator output shaft and an input signal. The following examples depicts this relation for an 4 – 20 mA input signal.

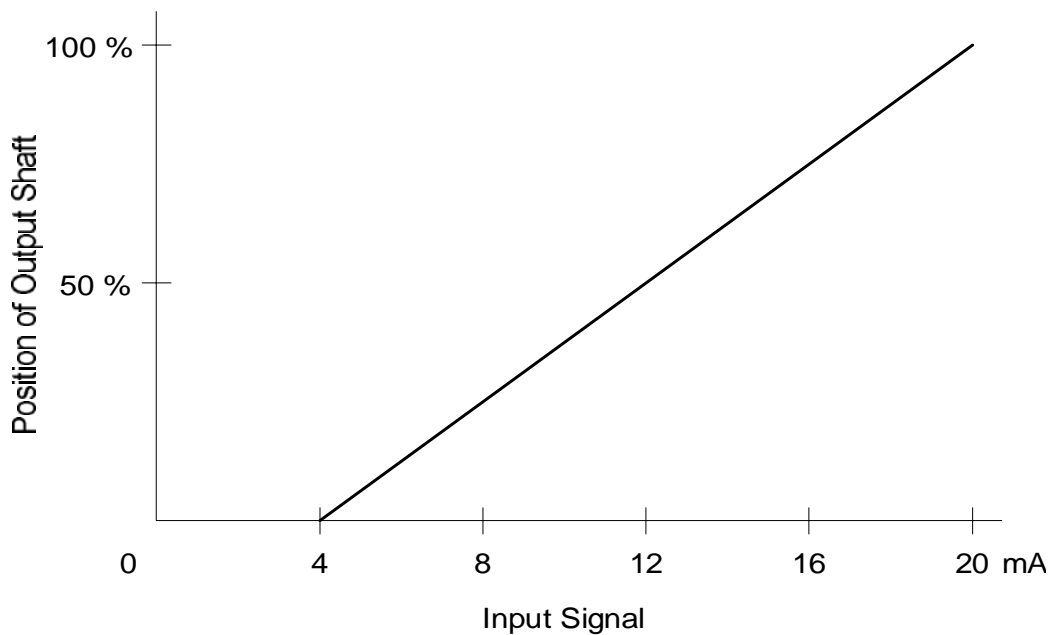

**Figure 1: Relation between Input Signal and Position**

Any one of options listed below can be selected for an input signal:

Current signals: 0 – 20 mA  
4 – 20 mA  
0 – 200 mA

Voltage signals: 0 – 5 V  
0 – 10 V

PMW signal: 0 – 100 %

### 3 Functional Block Diagram

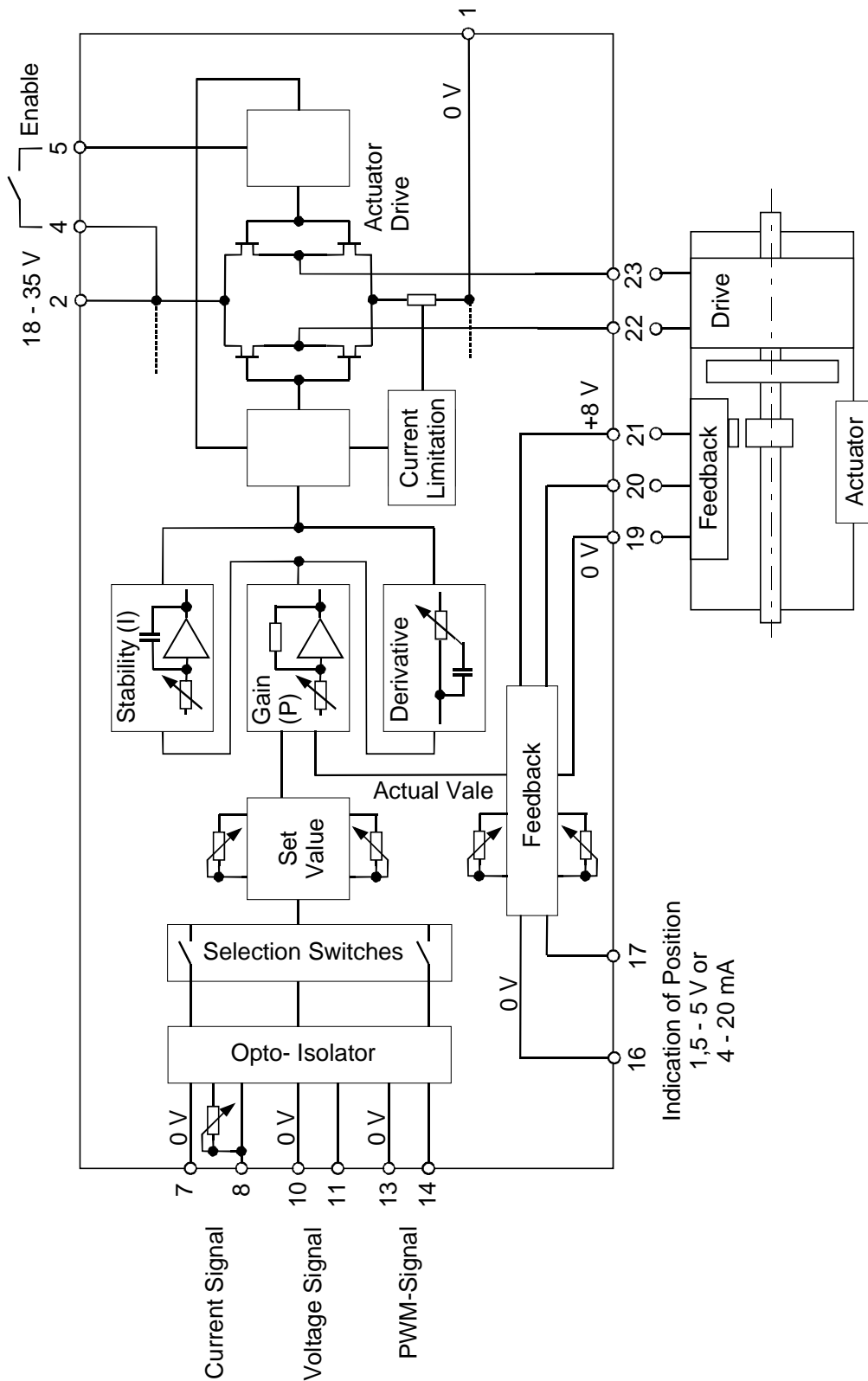

Figure 2: Functional Block Diagram

## 4 Operating Mode

The input signal, i.e. the position setpoint for the actuator output shaft is sent via an optoisolator and a selection switch to an actual/setpoint comparator receiving the actual value from the actuator feedback. Subsequent signal processing is performed by a PID position control circuit.

The position control circuit incorporates a 4-quadrant amplifier by which the actuator can be electrically driven in either direction. This will ensure optimum utilization of the actuator's rotational force together with very low current consumption in steady state operation which will also reduce heat build-up in the actuator.

An enable switch has been provided by which the actuator drive can be de-energized.

The feedback signal, i.e. the output shaft position signal, is available either as a current signal or, alternatively, as a voltage signal that can be used for further processing or for indicating actuator position.

## 5 Positioning Control Unit PKG .. - 04 - ..

### 5.1 Specification

supply voltage	24 V DC
maximum voltage	35 V DC
minimum voltage	20 V DC
maximum ripple voltage at max. actuator current	10 % at 100 Hz
acceptable voltage drop at max. actuator current	max. 10 % at control unit
fuse protection of governor	16 A
current consumption	approx. 250 mA + current of actuator

#### Values of input signals:

Current signal	0..20 mA	Input resistance	22 Ohms
	4..20 mA		22 Ohms
	0..200 mA		3 Ohms
Voltage signal	0..5 V DC	Input resistance	50 kOhms
	0..10 V DC		50 kOhms
PWM signal	0 - 100 %	Input resistance	2 kOhms

#### Values of output signal (position signal)

at zero position	1.5 V DC or 4 mA	
at 100% position	5 V DC or 20 mA	
steady state variation	±0.25 %.	
storing temperature	-55°C to +85°C.	
operating ambient temperature	-40°C to +70°C.	
humidity for protection grade	IP 00	up to 80 %.
	IP 55	up to 98 %
weight of protection type	IP 00	approx. 1.2 kg
	IP 55	approx. 3 kg

## 5.2 Versions

The control unit is available in two versions, one with protection grade IP 00 for installation in control cubicles, the other with protection grade IP 55 for other installations.

Its designation is composed as follows:

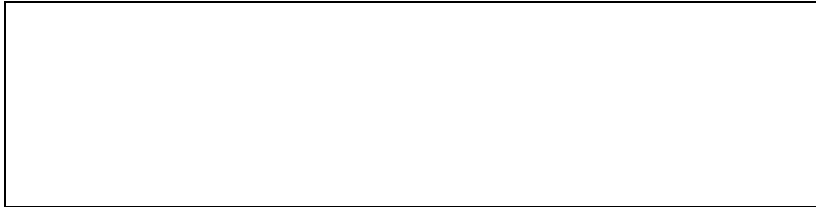

e.g.,    PKG 6 - 04 - 55            combined with actuator StG 6-01, protection grade IP 55  
          PKG 2040 - 04 - 00       combined with actuator StG 2040-01, protection grade IP  
00

### 5.3 Measurements

Positioning Control Unit PKG .. - 04 - 55

(protection grade 55)

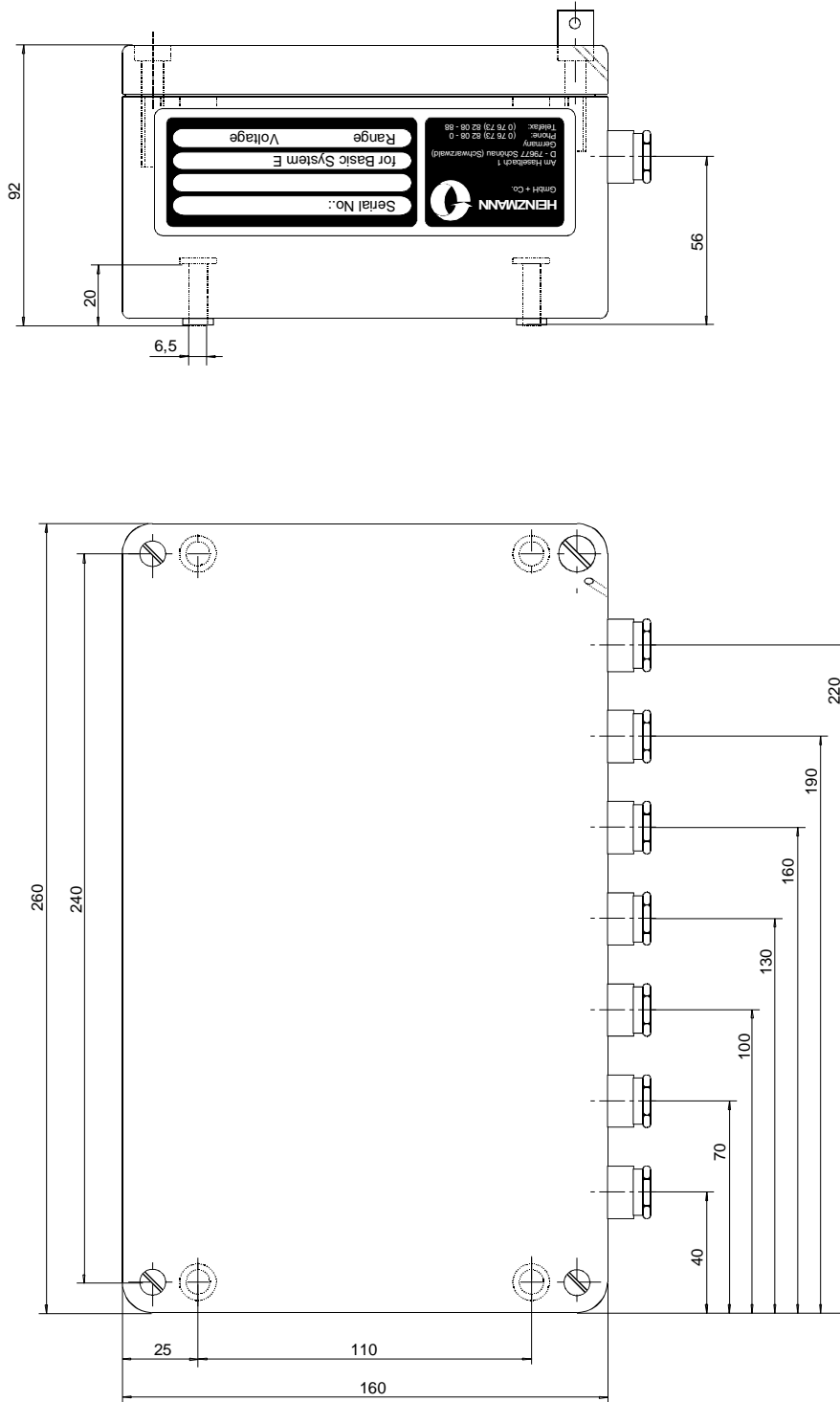

Figure 3: Dimensional Drawing PKG .. - 04 - 55

Positioning Control Unit PKG .. - 04 - 00  
(protection grade 00)

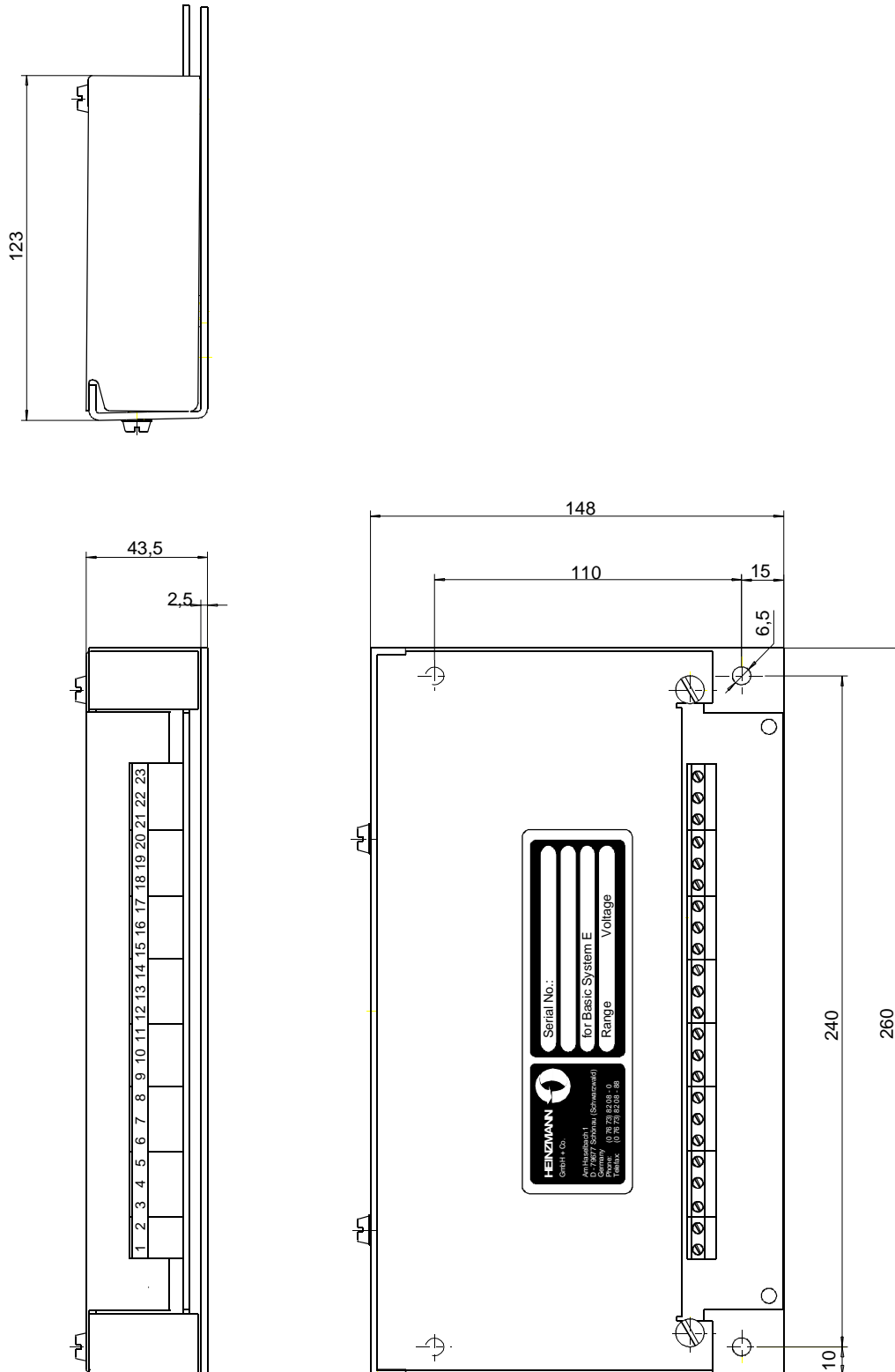
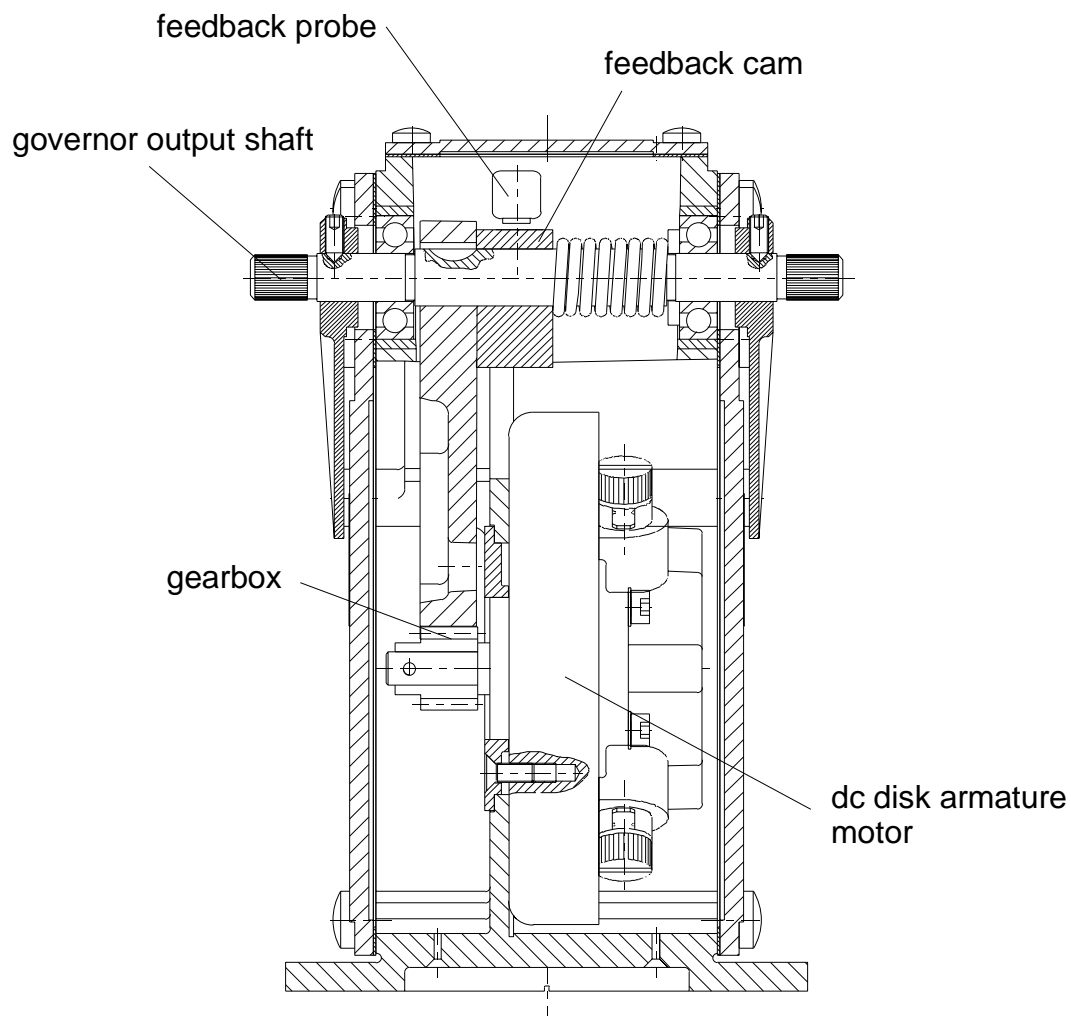

Figure 4: Dimensional Drawing PKG .. - 04 - 00

## 6 Actuators

### 6.1 Design and Mode of Operation

#### 6.1.1 Actuators StG 6-01 up to StG 40-01



**Figure 5: Principle of Actuator (Example StG 6-01)**

The power source of these actuators are DC disk motors whose torque is transmitted to the governor output shaft by an intermediate gear.

By using special materials and long-term lubricants the actuators are maintenance-free and have a long service life.

The governor output shaft is provided with a feedback cam for contactless sensing by a probe transmitting the accurate output shaft position to the control unit.

When the actuator is driven against a mechanical stop current limitation will take effect after approx. 20 seconds and reduce current to the actuator to a value sufficiently low to prevent damage to the actuator. If the actuator is not energized a weak pull-back spring will turn the output shaft back to zero position.

### 6.1.2 Actuators StG 2010-01 up to 2080-01

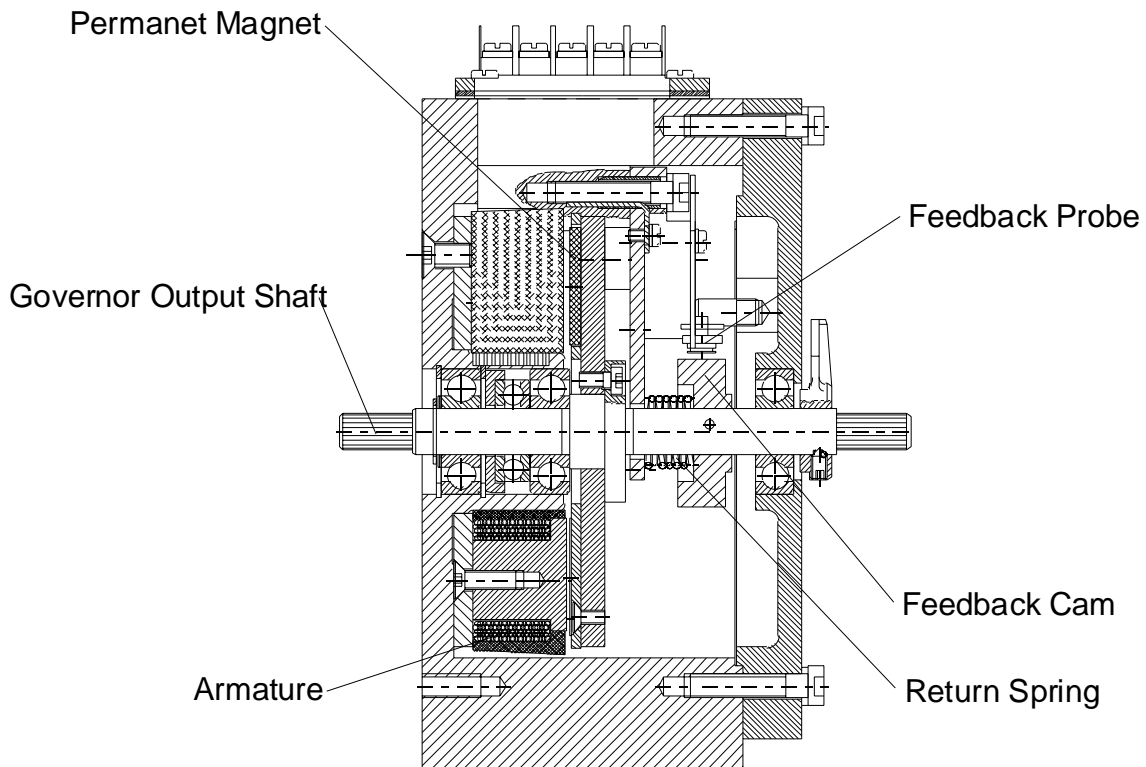

**Figure 6: Principle of StG 2010-01 up to 2080-01**

With this type actuator, a multi-polar magnetized permanent magnet is mounted on the output shaft. Opposite the permanent magnet an armature with the working coils is mounted. When current is applied to the working coils, torque in one direction is generated. Reversing current polarity will generate torque in the opposite direction.

As to feedback, current limitation, etc., the same comments will apply as have been made with regard to the actuators StG 6-01 up to StG 40-01.

Altogether, this type of actuator offers the following advantages:

- High regulating power working in either direction.
- Extremely low current consumption during steady state and relatively low current consumption on changes of load.
- Indifference to slow voltage changes of power supply; abrupt voltage changes, however, will cause governor disturbances.

## **6.2 Installation**

The actuator must be firmly mounted on the engine using a support with stiffened brackets. Vibrating arrangements as may be caused by weak bracket material or missing stiffenings must be avoided by all means as this will increase vibrations and lead to faster wear of actuator and linkage.

### 6.3 Specification

	StG 6 - 01	StG 6 – 02 - V
Efective rotation at the output shaft	36°	36°
Max. torque at the governor output shaft	approx. 4 Nm	approx. 6 Nm
Torque in steady state condition	approx. 1.3 Nm	approx. 2 Nm
Response time 0-100 % without load	approx. 70 ms	approx. 75 ms
Current consumption of whole governor maximum current	approx. 5 A	approx. 5 A
safe current in steady state condition	approx. 1.7 A	approx. 1.7 A
Storage temperature	-55°C up to +110°C	-55°C up to +110°C
Ambiente emperature in operation	-25°C up to +90°C	-25°C up to +90°C
Ambiente temperature special version	-40°C up to +90°C	-40°C up to +90°C
Humidity	up to 98 %	up to 98 %
Protection grade	IP 55	IP 55
Weight	approx. 3.5 kg	approx. 3.5 kg

	<b>StG 10 - 01</b>	<b>StG 16 - 01</b>
Efective rotation at the output shaft	36°	42°
Max. torque at the governor output shaft	approx. 10 Nm	approx. 15 Nm
Torque in steady state condition	approx. 3.3 Nm	approx. 5 Nm
Response time 0-100 % without load	approx. 80 ms	approx. 120 ms
Current consumption of whole governor maximum current	approx. 5 A	approx. 5 A
safe current in steady state condition	approx. 1.7 A	approx. 1.7 A
Storage temperature	-55°C up to +110°C	-55°C up to +110°C
Ambiente emperature in operation	-25°C up to +90°C	-25°C up to +90°C
Ambiente temperature special version	-40°C up to +90°C	-40°C up to +90°C
Humidity	up to 98 %	up to 98 %
Protection grade	IP 55	IP 55
Weight without base	approx. 4.3 kg	approx. 12.3 kg
Weight of base		approx. 1.3 kg

	<b>StG 30- 01</b>	<b>StG 40 - 01</b>
Efective rotation at the output shaft	42°	42°
Max. torque at the governor output shaft	approx. 28 Nm	approx. 44 Nm
Torque in steady state condition	approx. 9 Nm	approx. 14.5 Nm
Response time 0-100 % without load	approx. 170 ms	approx. 190 ms
Current consumption of whole governor		
maximum current	approx. 5 A	approx. 7 A
safe current in steady state condition	approx. 1.7 A	approx. 2.3 A
Storage temperature	-55°C up to +110°C	-55°C up to +110°C
Ambiente emperature in operation	-25°C up to +90°C	-25°C up to +90°C
Ambiente temperature special version	-40°C up to +90°C	-40°C up to +90°C
Humidity	up to 98 %	up to 98 %
Protection grade	IP 55	IP 55
Weight without base	approx. 12.3 kg	approx. 12.3 kg
Weight of base	approx. 1.3 kg	approx. 1.3 kg

	<b>StG 2010 - 01</b>	<b>StG 2040 – 01</b>
Efective rotation at the output shaft	36°	36°
Max. torque at the governor output shaft	approx. 1.4 Nm	approx. 6.5 Nm
Torque in steady state condition	approx. 0.45 Nm	approx. 2.2 Nm
Response time 0-100 % without load	approx. 45 ms	approx. 50 ms
Current consumption of whole governor		
maximum current	approx. 5 A	approx. 5 A
safe current in steady state condition	approx. 1.7 A	approx. 1.7 A
Storage temperature	-55°C up to +110°C	-55°C up to +110°C
Ambiente emperature in operation	-25°C up to +90°C	-25°C up to +90°C
Ambiente temperature special version	-40°C up to +90°C	-40°C up to +90°C
Humidity	up to 98 %	up to 98 %
Protection grade		
housing	IP 65	IP 65
connectors	IP 55	IP 55
Weight	approx. 2.2 kg	approx. 4.6 kg

	<b>StG 2080 - 01</b>
Efective rotation at the output shaft	36°
Max. torque at the governor output shaft	approx. 11 Nm
Torque in steady state condition	approx. 4 Nm
Response time 0-100 % without load	approx. 60 ms
Current consumption of whole governor:	
maximum current	approx. 5 A
safe current in steady state condition	approx. 1.7 A
Storage temperature	-55°C up to +110°C
Ambiente emperature in operation	-25°C up to +90°C
Ambiente temperature special version	-40°C up to +90°C
Humidity	up to 98 %
Protection grade	
housing	IP 65
connectors	IP 55
Weight	approx. 7.7 kg

### 6.4 Measurements

StG 6-01 and StG 6-02 V

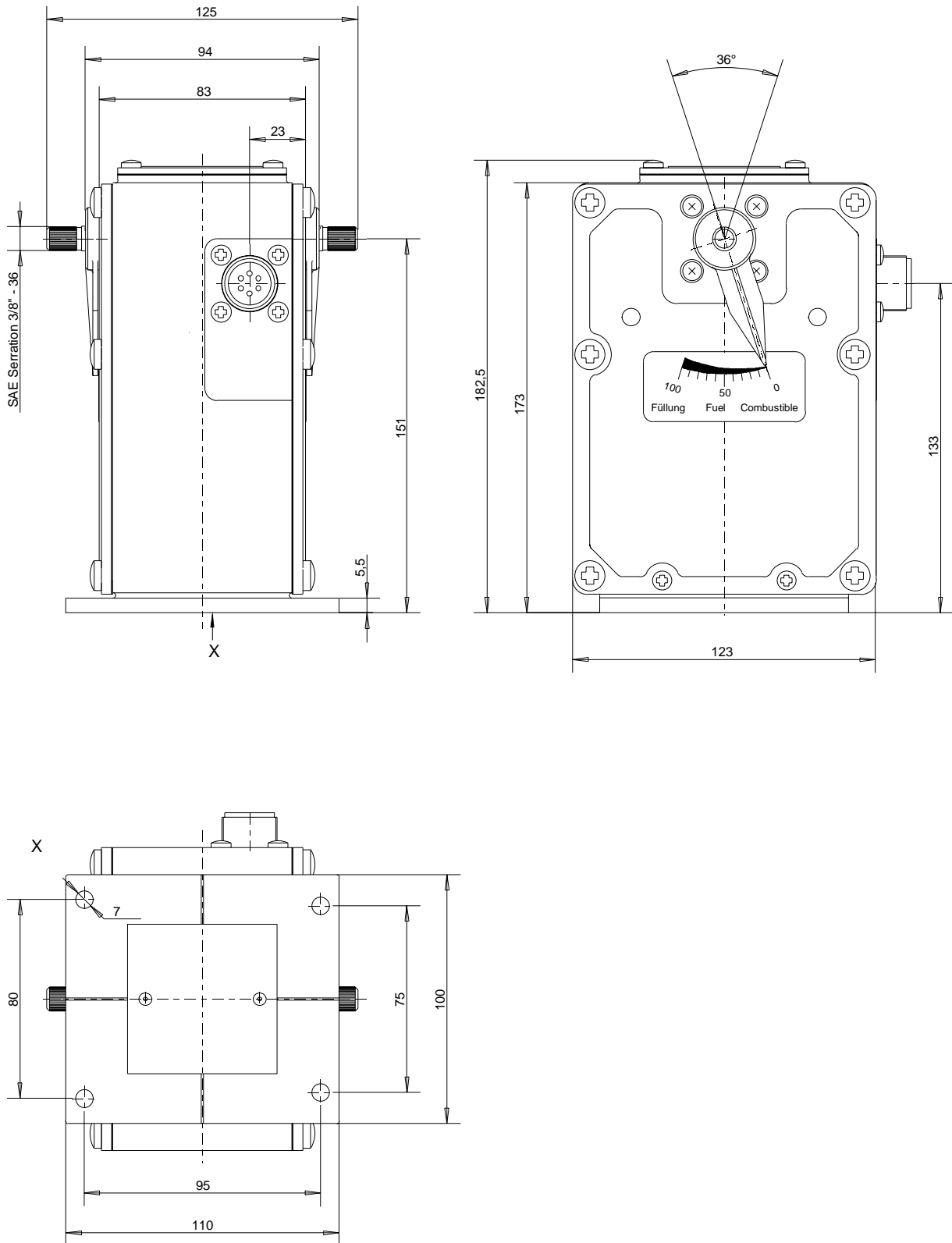

Figure 7: Dimensional Drawing StG 6-01 and StG 6-02 V

StG 10-01

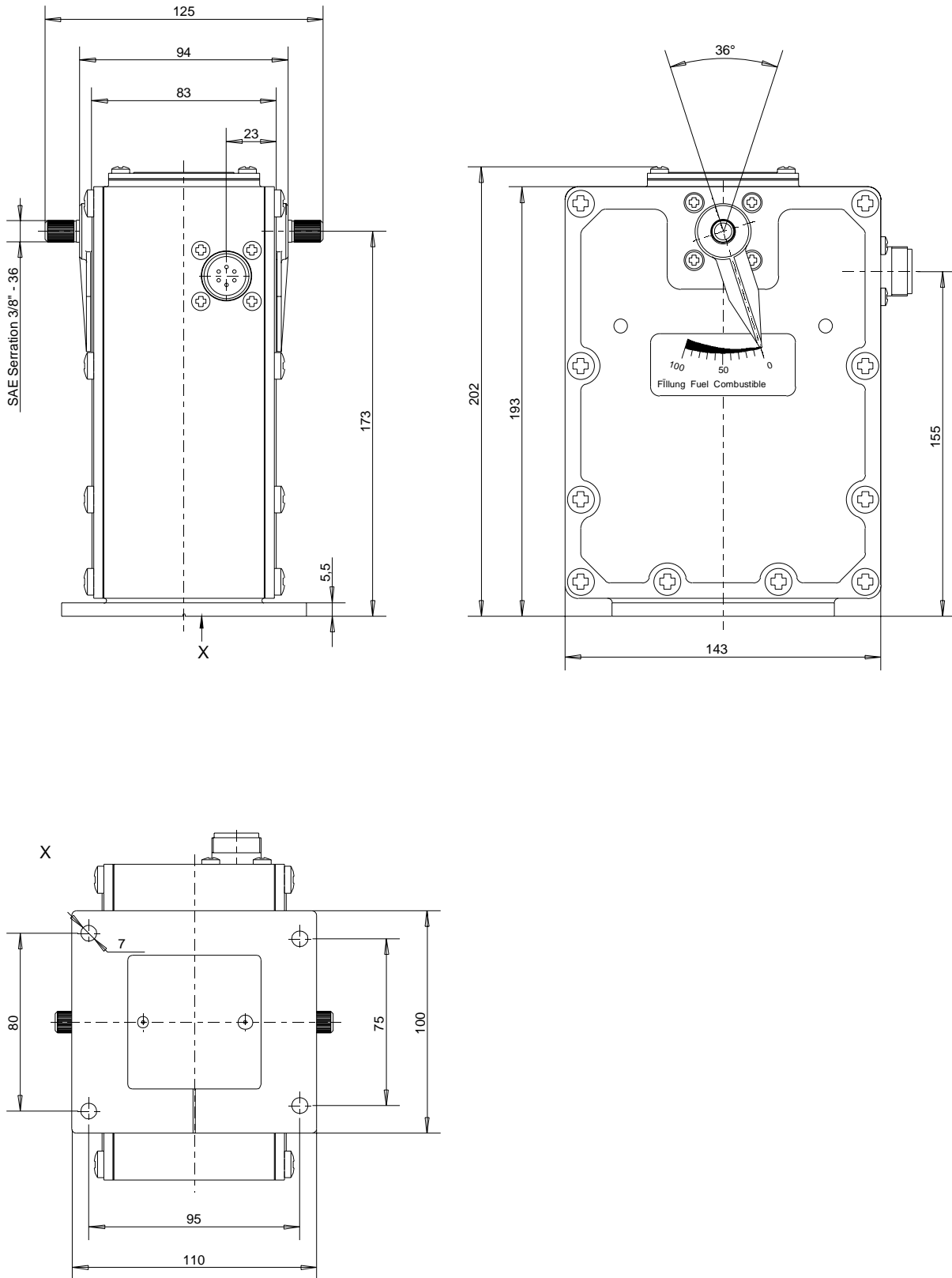

Figure 8: Dimensional Drawing StG 10-01

StG 16-01, StG 30-01 and StG 40-01

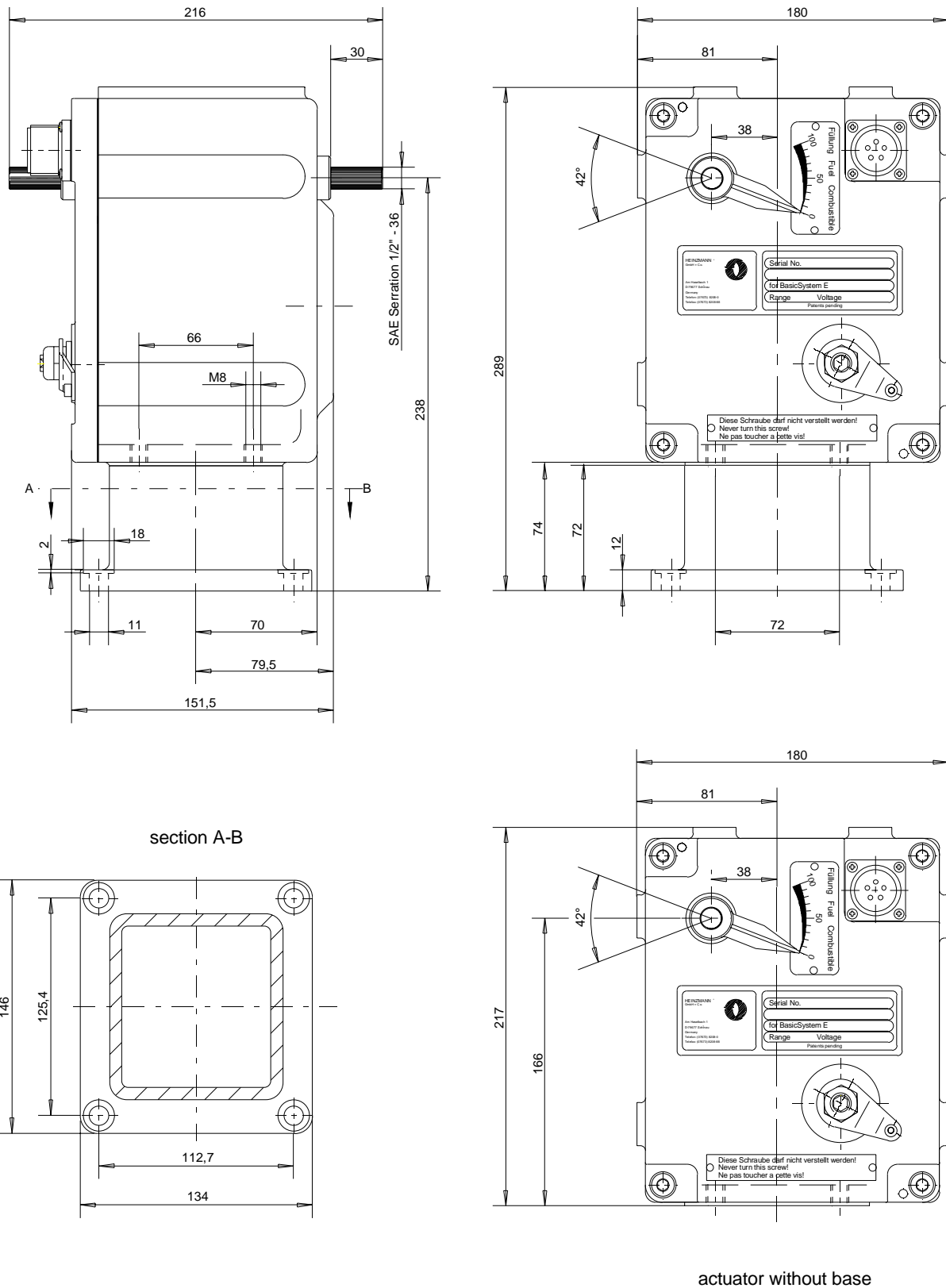

Figure 9: Dimensional Drawing StG 16-01, StG 30-01 and StG 40-01

StG 2010-01

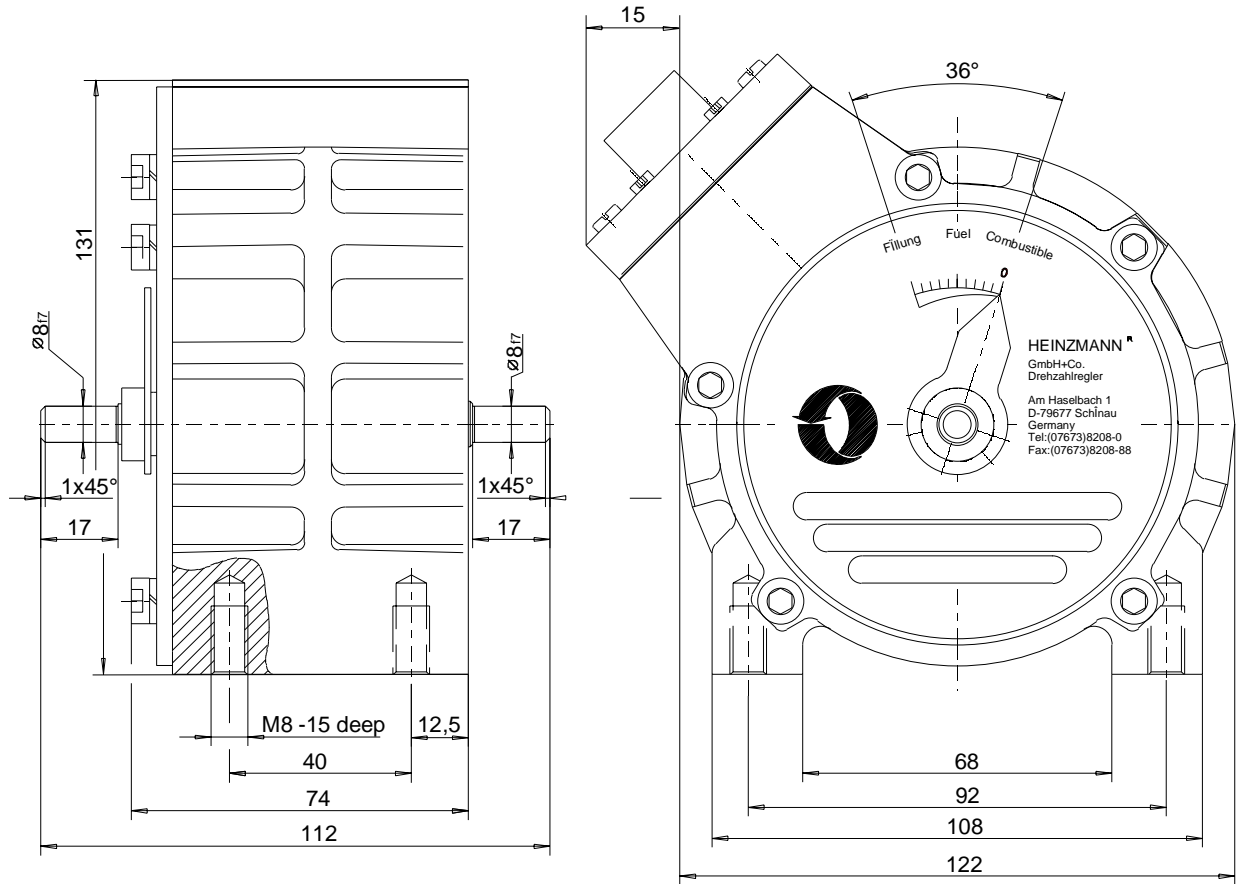

Figure 10: Dimensional Drawing StG 2010-01

StG 2040-01

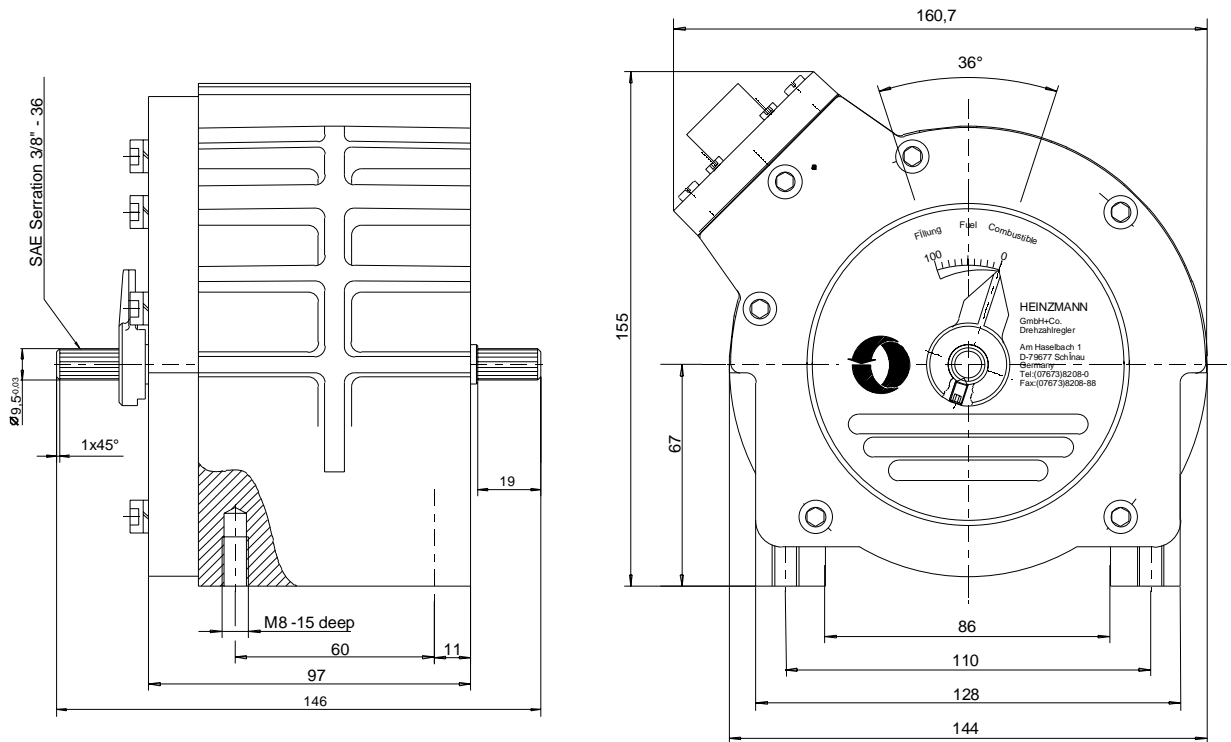

Figure 11: Dimensional Drawing StG 2040-01

StG 2080-01

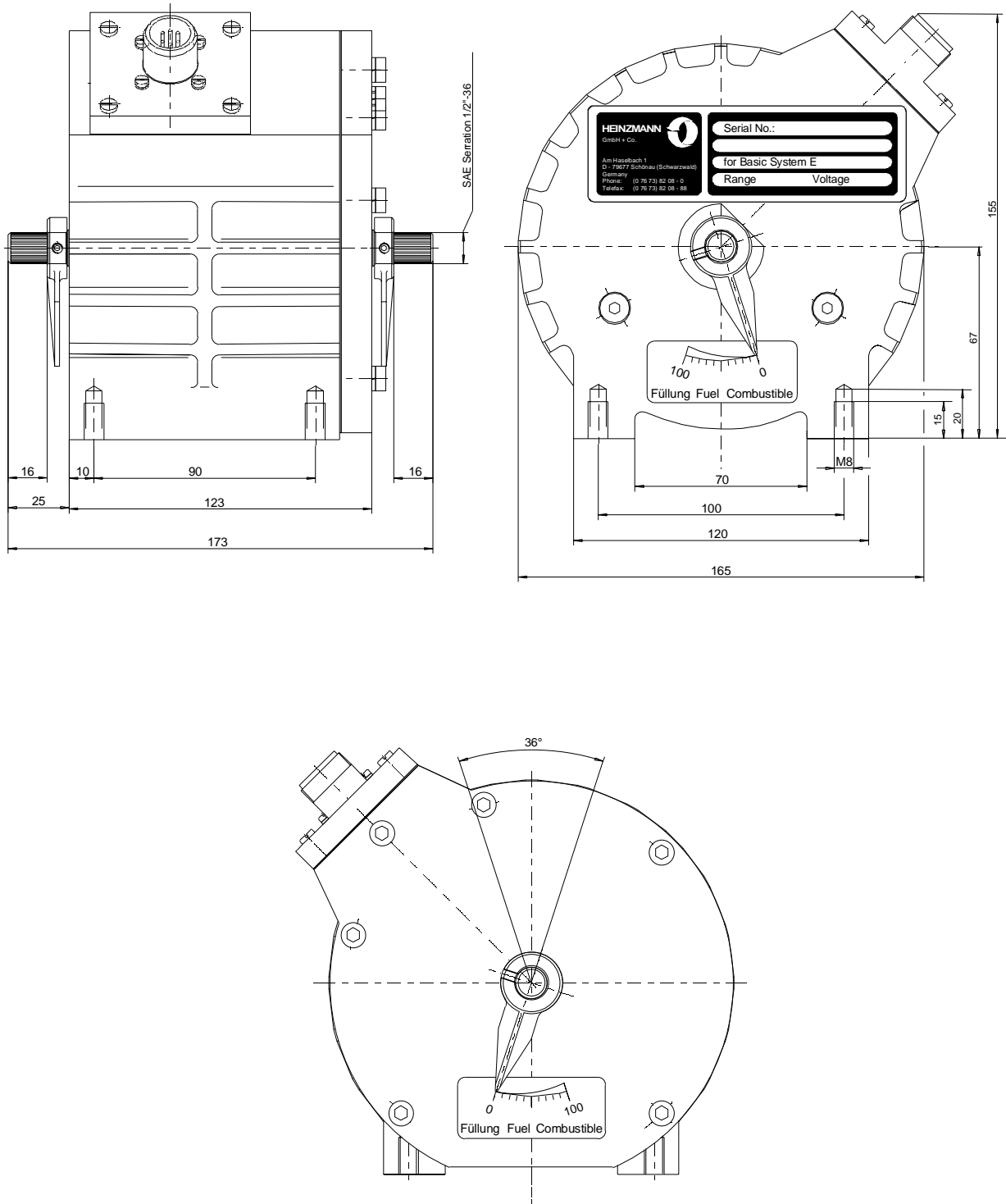

Figure 12: Dimensional Drawing StG 2080-01

## 7 Regulating Linkage

### 7.1 Length of Lever Arm

The length of the lever arm is determined in such a way that approx. 90 % of the governor output shaft adjustment angle can be used. Based on this, the rack length  $L$  of governors with  $36^\circ$  adjustment angle is calculated as  $L = 1.8 a$ , "a" being the travel distance of the injection pump or the carburettor.

### 7.2 Connecting Linkage

The connecting linkage from the governor to the injection pump or the carburettor should be length-adjustable and have a (pressure or tension) elastic link. If the actuators torque is less than 10 Nm, the elastic link is not needed. If possible, joint rod heads in accordance with DIN 648 should be used as connecting links. The linkage must operate easily and without clearance.

In case of friction or backlash in the linkage connecting actuator and injection pump resp. throttle valve no optimal control is possible.

### 7.3 Linkage Adjustment for Diesel Engines

The length of the connecting linkage is adjusted in such a way that with the governor in stop position the injection pump is set to 0 - 2 fuel marks. (Travel of the injection pump control rack is limited by the governor.)

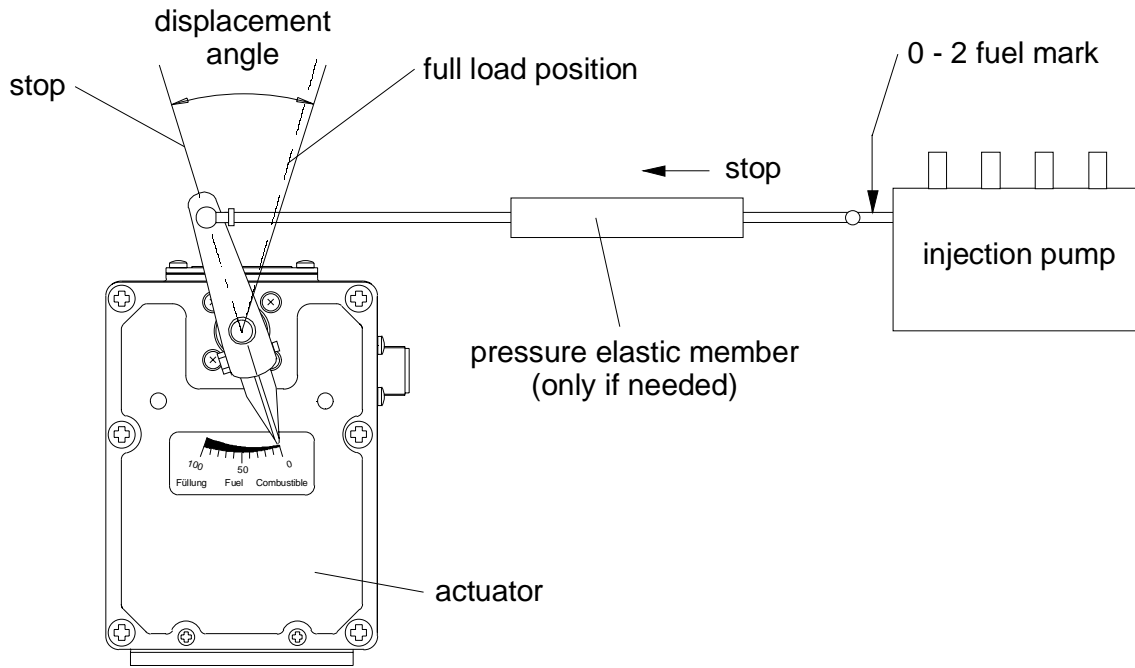
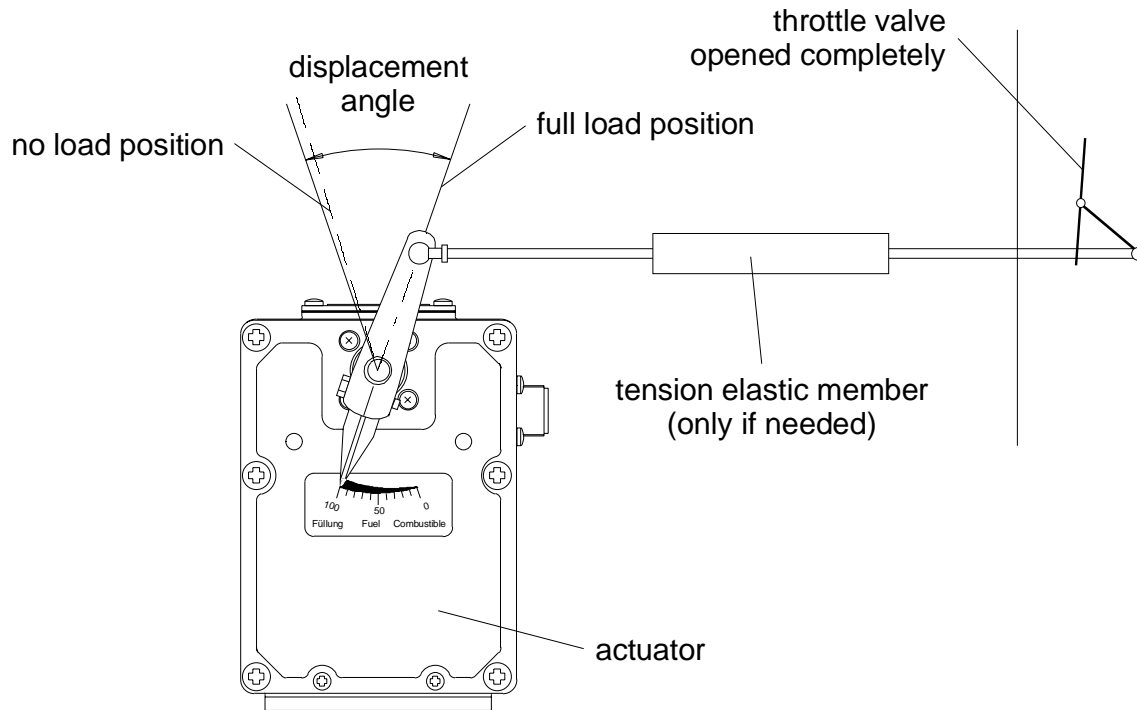

**Figure 13: Linkage for Diesel Engines**

The resistance of the pressure elastic link is overcome when the control rack has reached the full load stop and the speed continues to decrease (overload). Furthermore, the elastic link is overcome when stopping via the emergency switch.

### 7.4 Linkage Adjustment for Carburettor Engines

For carburettor or gas engines, the length of the connecting linkage is adjusted in such a way that with the governor in full load position the throttle valve is completely open. In idling speed position, the elastic link must be slightly overcome. This allows adjustment of the idle screw without changing the governor adjustment.



**Figure 14: Linkage for Gas Engines**

If carburettor or injection pump are to the left of the governor as opposed to their position on the drawings, then the direction of motion of the elastic link must also be reversed.

# 8 Electrical Connection

## 8.1 Wiring Diagram

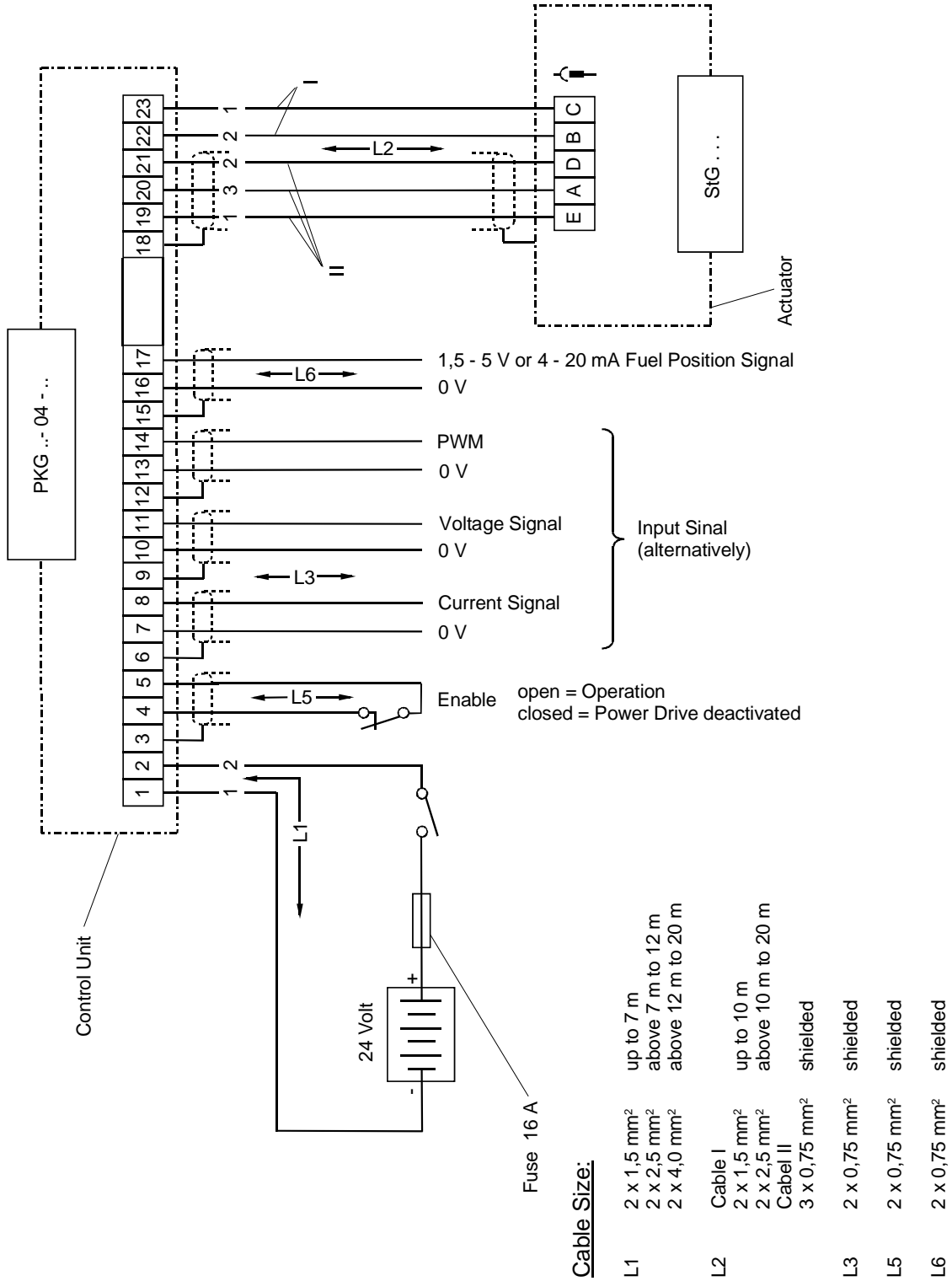

Figure 15: Wiring Diagram PKG .. - 04 - ..

## 8.2 Connection of Power Supply

Inappropriate choice of power supply or insufficient battery capacitance or incorrect connection of the power supply line or too small cable sizes of the feed line and the motor line of the actuator are bound have an adverse effect upon the performance of the speed governor. In steady state operation, this will cause a heavy increase of current consumption and unnecessary vibration of the actuator drive. The high current consumption will in its turn lead to overheating of the actuator or the amplifier in the control unit, and the vibration will result in premature wear of the gear and bearing parts or of the linkage.



Note

*In altogether, the lifetime of the control system is distinctly reduced by the errors described above.*

The following figure shows both a wrong and a correct cabling::

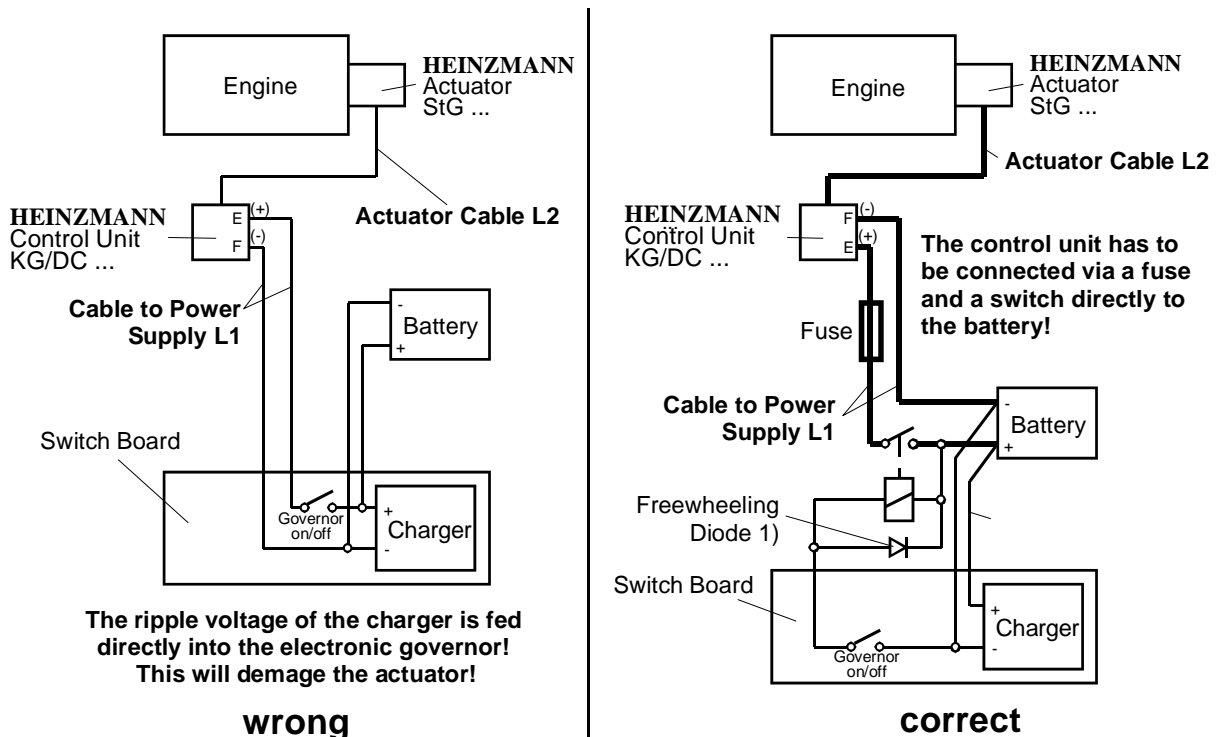

1) Coils (e.g. stopping solenoid, gas valve) have to be equipped with a protective circuit to eliminate high inductance voltages. Diode type e.g. 1N4002

Figure 16: Correct Connection of Power Supply



Warning

*If there are battery chargers with rapid charge mode installed in the plant, the rapid charge mode should no be used during operation.*

If there is no battery provided, **it is absolutely necessary** that a three phase power supply or a **stabilized** one phase power supply with at least 24 V DC, 10 Amps output power **be used** as a power source.



**Warning**

*The cable sizes and cable lengths described in the wiring diagrams must not be exceeded!*

When power supply, battery and cabling have been correctly dimensioned, then on starting the engine or with the actuator operating at maximum current consumption (approx. 6.4 Amps), a drop of the supply voltage directly at the control unit of approx. 2 Volts maximum only will be admissible.

## 9 Adjustment

Normally, the devices have been calibrated completely at the factory. The following adjustment instructions are intended as a help for readjustments or corrections.

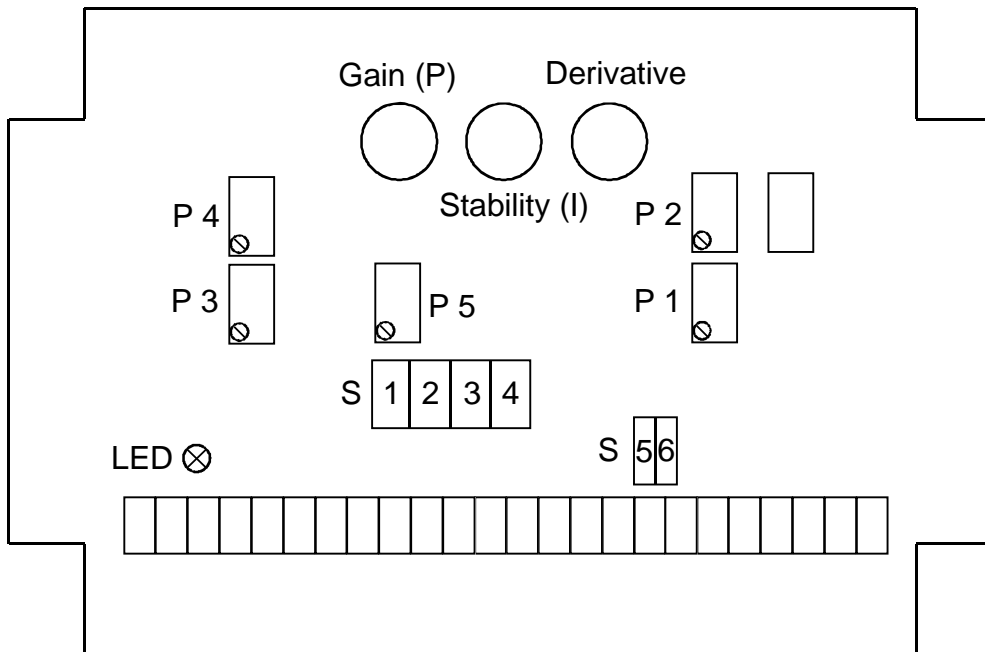











Figure 17: Adjustment Switches and Potentiometers PKG .. - 04 ..

### 9.1 Power Supply Indication

With power supply turned on, the green LED will be alight.

## 9.2 Selection Switches

The selection switches S1 through S6 are to be set according to the below table:

Switch	Switch position	Functions
S1		Actuator connected: StG 6-01 ... StG 40-01
		Actuator connected: StG 2010-01 ... StG 2080-01
S2		Current input: input signal 4 up to 20 mA
		Current input: input signal 0 up to 200 mA
S3		Selection of current input (signal range according to selected position of S2)
		Selection of voltage input 0 up to 10 V
S4		Selection of DC signal inputs
		Selection of PWM signal input
S5 and S6		Current output: output signal 4 to 20 mA
		Voltage output: output signal 1.5 to 5 V

### 9.3 Adjusting Output Signal

Follow the instructions in above table to set the switches S5 and S6 for the desired output signal.

Connect measuring instrument with appropriate measuring range to terminal 16 (0 V) and terminal 17.

Close enable switch or bridge terminals 4 and 5.

Power up.

Use potentiometer P1 in 0% position to adjust the low output signal.

Push actuator manually to 100% position and use potentiometer P2 to adjust the high output signal.

Check both values and readjust if necessary.

Open enable switch or remove bridge.



Note

*By standard, the range is adjusted for 1.5 V to 5 V so that the HEINZMANN Test Device PG 01 can be used for simulation of the speed control system. If a different range is desired, it should by all means be specified in your order as this will require additional calibration at the factory.*

### 9.4 Adjusting Dynamics

Turn the potentiometers for gain, stability and derivative counterclockwise to their stops.

Apply approximate mean value of the input signal.

To perform the adjustments as explained below, close the enable switch, open it again and optimize the transient response:

Turn gain clockwise until engine becomes unstable, then turn back until it is stable again.

Turn stability clockwise until engine becomes unstable, then turn back until it is stable again.

Turn derivative clockwise until engine becomes unstable, then turn back until it is stable again.

### **9.5 Adjusting Input Signal**

Apply minimum input signal and set actuation start using potentiometer P3.

Use output signal indicated by measuring device for actuation start.

Apply maximum input signal and set actuation stop by means of potentiometer P4.

Check both values and readjust if necessary.

Actuation start for the voltage input can, in addition, be set by means of potentiometer P5.

Remove measuring instrument.



## 11 Special Application: Actuators with integrated Positioning Electronic

In these actuators the complete electronic including the power drive is already installed in the actuator housing. Via one plug the actuator gets the supply voltage and the positioning setpoint. With the same plug there is a position proportional output signal available.

The input signal can be a current or PWM-signal. The output signal can be a current or voltage signal.

All adaptations and the adjustments of the dynamic values are made during the production and testing at HEINZMANN. So there is no adjustment necessary and possible in the field anymore.

### 11.1 General Specifications

supply voltage	24 V DC
maximum voltage	35 V DC
minimum voltage	20 V DC
maximum ripple voltage at max. actuator current	10 % at 100 Hz
acceptable voltage drop at max. actuator current	max. 10 % at control unit
fuse protection of governor	16 A
Values of input signals:	
Current signal 0..20 mA	Input resistance 270 Ohms
PWM signal 10 - 90 %	Input resistance 1 kOhm
Values of output signal (position signal)	
at zero position	1 V DC or 4 mA
at 100% position	9 V DC or 20 mA
steady state variation	±0.25 %.
storing temperature	-55°C to +85°C.
operating ambient temperature	-40°C to +70°C.
humidity	up to 98 %
protection grade	IP 44
weight	approx. 22.7 kg

## 11.2 Actuator Type dependent Specifications

	<b>StG 16.90 - 03</b>	<b>StG 30.90 - 03</b>
Efective rotation at the output shaft	90°	90°
Max. torque at the governor output shaft	approx. 15 Nm	approx. 28 Nm
Torque in steady state condition	approx. 5 Nm	approx. 9 Nm
Response time 0-100 % without load	approx. 240 ms	approx. 340 ms
Current consumption of whole governor		
maximum current	approx. 5 A	approx. 5 A
safe current in steady state condition	approx. 1.7 A	approx. 1.7 A

	<b>StG 40.90 - 03</b>
Efective rotation at the output shaft	90°
Max. torque at the governor output shaft	approx. 44 Nm
Torque in steady state condition	approx. 14.5 Nm
Response time 0-100 % without load	approx. 380 ms
Current consumption of whole governor:	
maximum current	approx. 5 A
safe current in steady state condition	approx. 1.7 A

### 11.3 Measurements

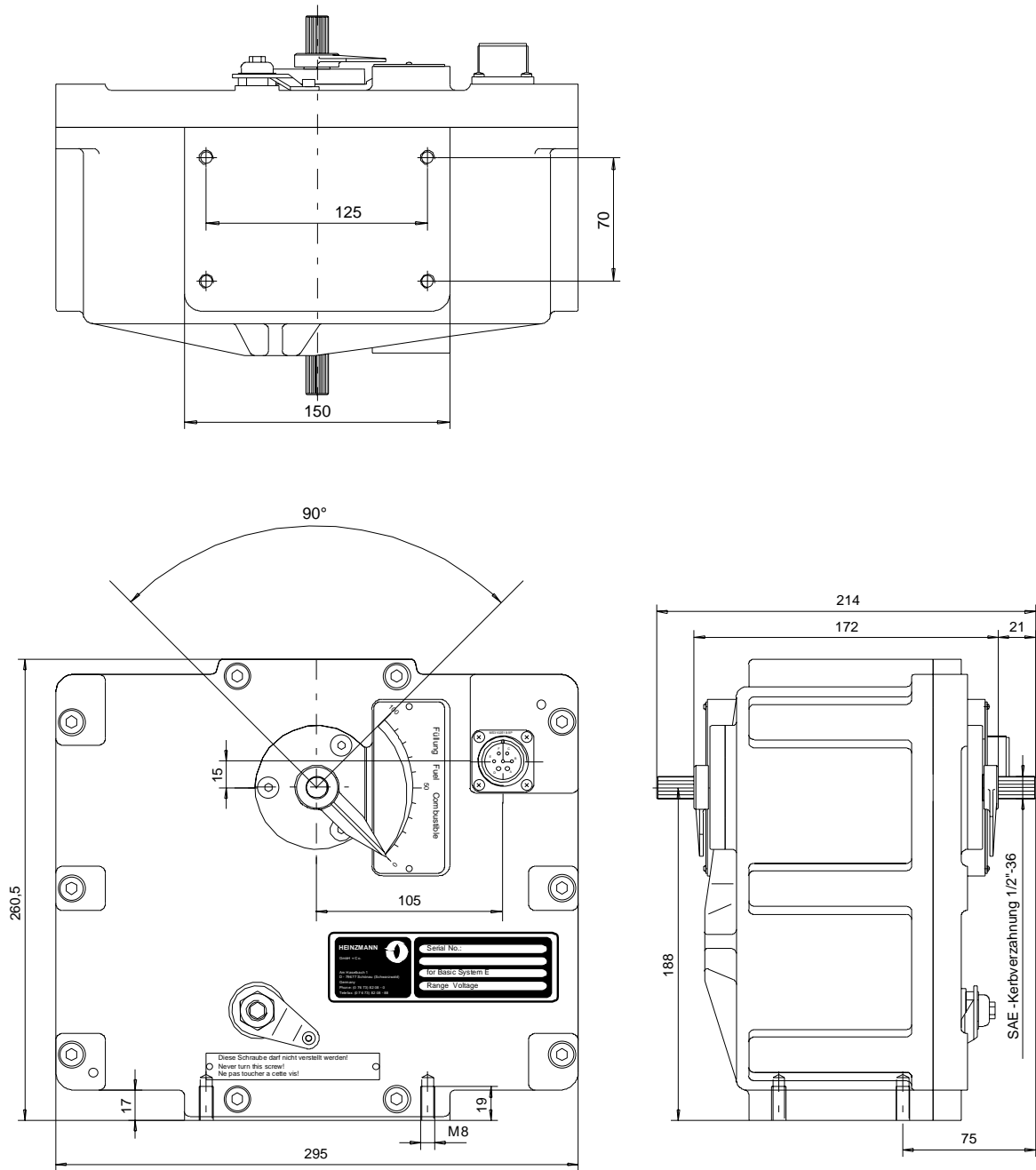
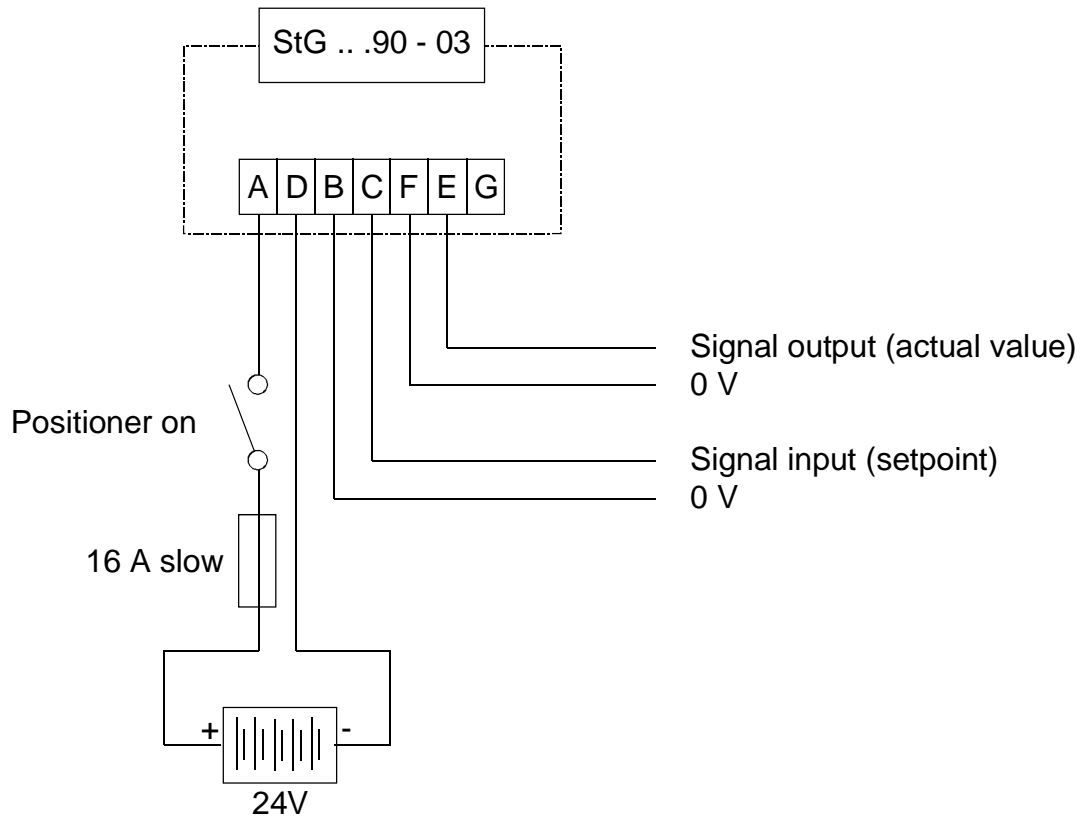

Figure 18: Dimensional Drawing StG 16.90 - 03, StG 30.90 - 03 and StG 40.90 - 03

### 11.4 Wiring Diagram



Cable size

24 V- supply	
up to 10 m	2,5 mm <sup>2</sup>
over 10 m up to 20 m	4,0 mm <sup>2</sup>
rest	0,75 mm <sup>2</sup>

**Figure 19: Wiring Diagram**

The plug of the cable to connect with the positioner has the designation:

SV 30 - StG - 7 KW (EDV- No.: 010 02 117 01)



## 12 Figure List

Figure 1: Relation between Input Signal and Position.....	4
Figure 2: Functional Block Diagram.....	5
Figure 3: Dimensional Drawing PKG .. - 04 - 55 .....	9
Figure 4: Dimensional Drawing PKG .. - 04 - 00 .....	10
Figure 5: Principle of Actuator (Example StG 6-01) .....	11
Figure 6: Principle of StG 2010-01 up to 2080-01 .....	12
Figure 7: Dimensional Drawing StG 6-01 and StG 6-02 V .....	19
Figure 8: Dimensional Drawing StG 10-01 .....	20
Figure 9: Dimensional Drawing StG 16-01, StG 30-01 and StG 40-01 .....	21
Figure 10: Dimensional Drawing StG 2010-01 .....	22
Figure 11: Dimensional Drawing StG 2040-01 .....	23
Figure 12: Dimensional Drawing StG 2080-01 .....	24
Figure 13: Linkage for Diesel Engines .....	26
Figure 14: Linkage for Gas Engines .....	27
Figure 15: Wiring Diagram PKG .. - 04 - ..	28
Figure 16: Correct Connection of Power Supply .....	29
Figure 17: Adjustment Switches and Potentiometers PKG .. - 04 ..	31
Figure 18: Dimensional Drawing StG 16.90 - 03, StG 30.90 - 03 and StG 40.90 - 03 .....	38
Figure 19: Wiring Diagram.....	39

## 13 Order Specifications for Manuals

There is no charge for our technical manuals ordered in reasonable quantities.

Order the necessary manuals on our speed governors from your nearest

[HEINZMANN location](#).

(Please click on “HEINZMANN location” to see the list of our subsidiaries and agents in the world).

### **Please include the following information:**

- your name,
- the name and address of your company (you can simply include your business card),
- the address where you want the manuals sent (if different from above),
- the number(s) (as on front page bottom right) and title(s) of the desired manual(s),  
or the technical data of your HEINZMANN equipment,
- the quantity you want.

You can directly use the following fax-form for ordering one or several manuals.

Most of the manuals are available as acrobat PDF-files, too. On request they can be send via e-mail.

We solicit comments about the content and the presentation of our publications. Please, send your comments to:

**HEINZMANN GmbH & Co. KG**

Service Department

Am Haselbach 1

D-79677 Schönau

Germany

# Fax Reply

## Order for HEINZMANN technical manuals

**Fax-Hotline +49 7673 8208 194**

Please send me the following manuals:

Quantity	No. of the manual	Title

Please send me your new sales documentation about

( ) the HEINZMANN Analogue Governors      Application:.....

( ) the HEINZMANN Digital Governors      Application:.....

( ) the HEINZMANN Gas Engine Equipment      Application:.....

Company .....

Contact Person.....

Department .....

Address..... Country/Code/Town.....

Phone..... Fax .....

E-Mail.....

Activity.....

Date .....