

## StG 2040/2080

---

### DATA SHEET

#### Description

---

Medium sized and large diesel engines as well as gas engines or -turbines are the preferential application for this type of powerful actuators.

A multi-polar magnetised permanent magnet is mounted on the actuator shaft. Opposite of it a likewise multipolar armature is fixed. The design allows to generate powerful torque in both directions of working equally. A result of the direct acting gearless function are very fast response times. Optionally a return spring can be mounted on the output shaft to ensure setting to a zero position in case of voltage loss or similar.

A contactless feedback system mounted on the actuator shaft offers a precise electrical signal of shaft position to any external control device. If the actuator is blocked mechanically a current limitation is activated after approx. 20 seconds to prevent the actuator from overheating or damage. The use of special materials and long-duration lubricants assure maintenance-free operation and long service life. Altogether, this type of actuator provides high regulation power working in both directions at only low current consumption. It is indifferent to slow voltage changes of the supply and allows any fitting position. Several different electrical connecting variants are available.

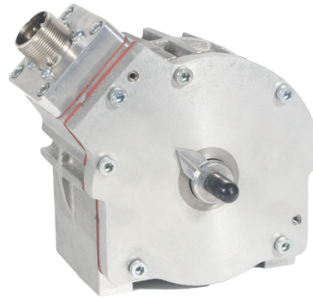

#### Features

---

Strong regulation torque working in both directions equally

---

Quick response time

---

Low current consumption on change of load

---

Extremely low retaining current

---

Indifference to slow voltage changes of the supply

---

Contactless feedback

---

Current limitation in case of blocking to prevent actuator overheating

---

Any mounting position possible

---

Maintenance-free

---

Return spring optional

#### Application range

---

- ➔ Medium sized and large diesel engines
- ➔ Gas engines
- ➔ Gas and steam turbines

#### Certificates

---

on request

# Dimensions

## StG 2040

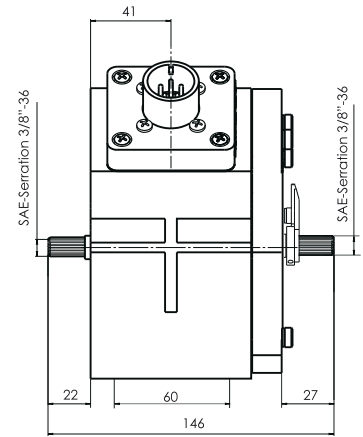
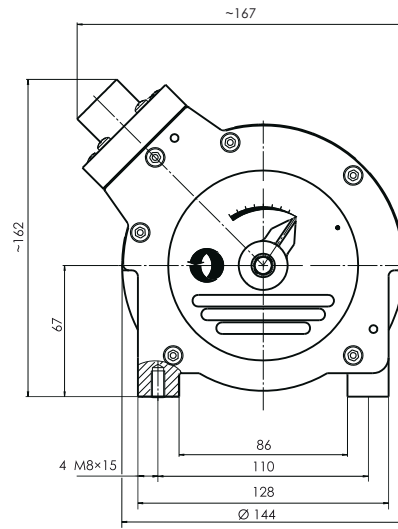

## StG 2080

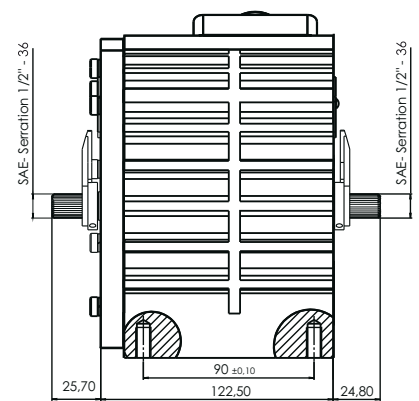
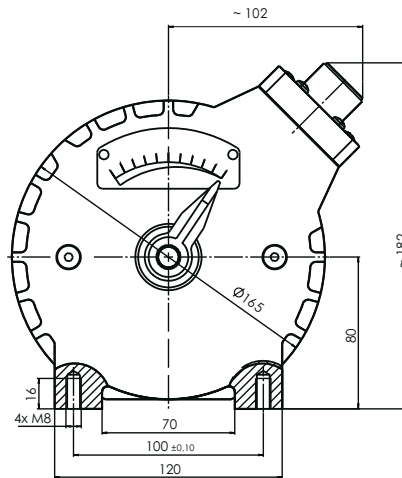

# Technical data

	StG 2040		StG 2080	
	36°	68°	36°	68°
Rotation angle	36°	68°	36°	68°
Torque	max. 7 Nm	max. 6 Nm	max. 12,5 Nm	max. 7 Nm
Steady state torque	max. 4 Nm	max. 3.5 Nm	max. 7.3 Nm	max. 4 Nm
Return torque, 100% position	~ 1.4 Nm	~ 1.4 Nm	~ 1.3 Nm	~ 1.6 Nm
Return torque, 0% position	~ 1.2 Nm	~ 1.0 Nm	~ 1 Nm	~ 1 Nm
No load response time	< 50 ms	< 100 ms	< 60 ms	< 100 ms
Current consumption	max. 6 A			
Steady state current	max. 3.5 A			
Position feedback (0 ... 100%)	approx. 1.6 ... 2.8 V DC,			
Ambiente temperature	-25 ... 90°C			
Storage temperature	-55 ... 110°C			
Permissible ambient humidity	< 95% at 55°C			
Vibration	± 1 mm at 1 ... 20 Hz, max. 0.24 m/s at 21 ... 63 Hz, max. 9 g at 64 ... 2000 Hz			
Shock	30 g, 11 ms, half sine			
Protection grade	Housing IP 65 Plug IP 65 Terminal IP 00			
Weight	approx. 6.6 kg		approx. 8.6 kg	

Subject to alterations. ©HEINZMANN GmbH & Co. KG, 2009