



Heinzmann GmbH & Co. KG
Engine & Turbine Controls

Am Haselbach 1
D-79677 Schönau (Schwarzwald)
Germany

Phone +49 7673 8208-0
Fax +49 7673 8208-188
E-mail info@heinzmann.com
www.heinzmann.com

V.A.T. No.: DE145551926

HEINZMANN®
Digital Electronic Speed Governors

Basic Systems

PRIAMOS I

DC 16.1-03





DC 30.1-03

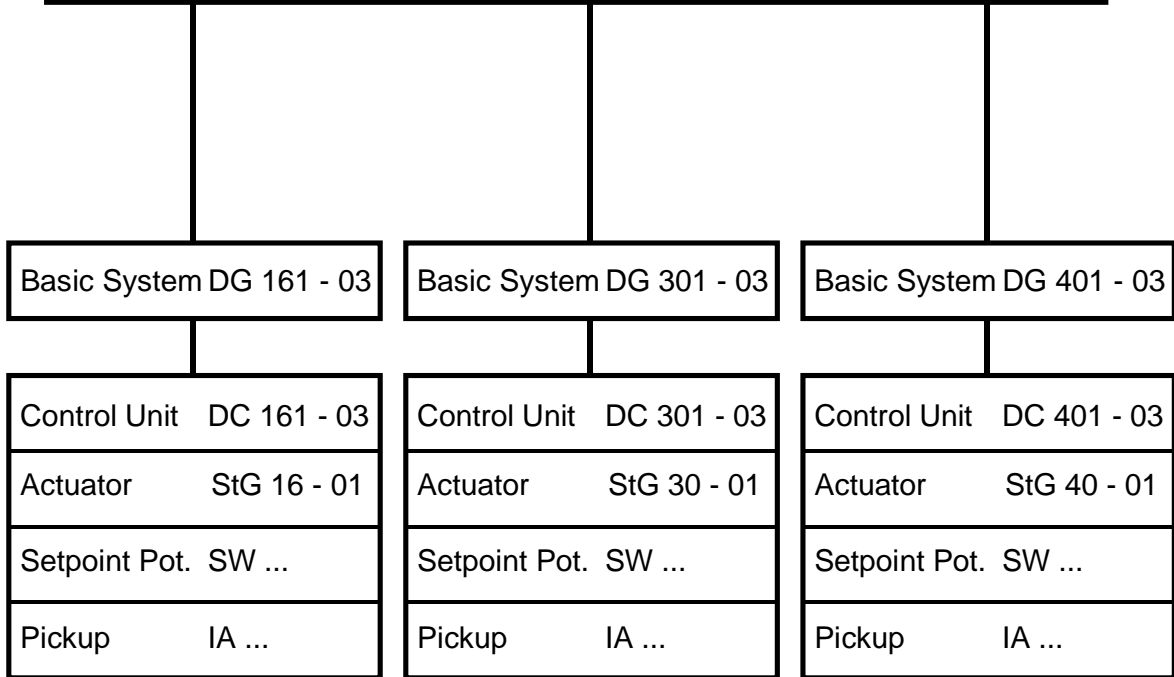

DC 40.1-03

Priamos I
for engines up to approx. 4000 kW



D : Digital
 DG : Digital Governor (Basic System)
 DC : Digital Control Unit
 StG : Actuator (**St**ellgerät)
 SW : Setpoint Potentiometer (**Soll**wertpot.)
 IA : Pickup (**Impuls**aufnehmer)

 <p>Warning</p>	<p>Read this entire manual and all other publications appertaining to the work to be performed before installing, operating or servicing your equipment.</p> <p>Practice all plant and safety instructions and precautions.</p>
 <p>Danger</p>	<p>Failure to follow instructions may result in personal injury and/or damage to property.</p> <p>HEINZMANN will refuse all liability for injury or damage which results from not following instructions</p>
 <p>Danger! High Voltage</p>  <p>Danger</p>	<p>Please note before commissioning the installation:</p> <p>Before starting to install any equipment, the installation must have been switched dead!</p> <p>Be sure to use cable shieldings and power supply connections meeting the requirements of the <i>European Directive concerning EMI</i>.</p> <p>Check the functionality of the existing protection and monitoring systems.</p>
 <p>Danger</p>	<p>To prevent damages to the equipment and personal injuries, it is imperative that the following monitoring and protection systems have been installed:</p> <p>Overspeed protection acting independently of the speed governor</p> <p>Overtemperature protection</p> <p>HEINZMANN will refuse all liability for damage which results from missing or insufficiently working overspeed protection</p> <p>Generator installation will in addition require:</p> <p>Overcurrent protection</p> <p>Protection against faulty synchronization due to excessive frequency, voltage or phase differences</p> <p>Reverse power protection</p>
	<p>Overspeeding can be caused by:</p> <p>Failure of the voltage supply</p> <p>Failure of the actuator, the control unit or of any accessory device</p> <p>Sluggish and blocking linkage</p>

 <p>Warning</p>	<p>Electronically controlled injection (MVC) will in addition require to observe the following:</p> <p>With Common Rail systems a separate mechanical flow limiter must be provided for each injector pipe.</p> <p>With Pump-Pipe-Nozzle (PPN) and Pump Nozzle (PNE) systems fuel release may be enabled only by the movement of control piston of the solenoid valve. This is to inhibit fuel from being delivered to the injection nozzle in case of seizure of the control piston.</p>
 <p>Warning</p>	<p>The examples, data and any other information in this manual are intended exclusively as instruction aids and should not be used in any particular application without independent testing and verification by the person making the application.</p>
 <p>Danger</p>	<p>Independent testing and verification are especially important in any application in which malfunction might result in personal injury or damage to property.</p>
	<p>HEINZMANN make no warranties, express or implied, that the examples, data, or other information in this volume are free of error, that they are consistent with industry standards, or that they will meet the requirements for any particular application.</p>
	<p>HEINZMANN expressly disclaim the implied warranties of merchantability and of fitness for any particular purpose, even if HEINZMANN have been advised of a particular purpose and even if a particular purpose is indicated in the manual.</p>
	<p>HEINZMANN also disclaim all liability for direct, indirect, incidental or consequential damages that result from any use of the examples, data, or other information contained in this manual.</p>
	<p>HEINZMANN make no warranties for the conception and engineering of the technical installation as a whole. This is the responsibility of the user and of his planning staff and specialists. It is also their responsibility to verify whether the performance features of our devices will meet the intended purposes. The user is also responsible for correct commissioning of the total installation.</p>

Contents

	Page
1 Safety Instructions and Related Symbols.....	1
1.1 Basic Safety Measures for Normal Operation.....	2
1.2 Basic Safety Measures for Servicing and Maintenance	2
1.3 Before Putting an Installation into Service after Maintenance and Repair Works.....	3
2 General Remarks.....	4
3 Mode of Operation	7
4 Block Diagram of the Digital Governor DG 16.1 - 03 up to DG 40.1 - 03.....	8
5 Sensors.....	9
5.1 Overview	9
5.2 Magnetic Pickup IA	10
5.2.1 Technical Datas.....	10
5.2.2 Installation	10
5.2.3 Tooth Profile	11
5.2.4 Clearance for IA 02 - 76 up to IA 13 - 102.....	11
5.2.5 Clearance for IA 22 - 76 and IA 23 - 102.....	11
5.2.6 Mounting Measurements	12
5.2.7 Redundant Speed Signal	12
5.3 Cooling Medium Temperature Sensor TS 01 - 28 - PT 1000	13
5.4 Pressure Sensors	14
5.4.1 Oil Pressure Sensor.....	14
5.4.2 Boost Pressure Sensors	15
5.4.2.1 Boost Pressure Sensor with Plug	15
5.4.2.2 Boost Pressure Sensor with Housing and Terminal Strip	16
6 Speed Setpoint Adjusters.....	17
6.1 Setpoint Potentiometer SW 01 - 1 - b (1 turn).....	17
6.2 Setpoint Potentiometer SW 02 - 10 - b (10- turn)	17
6.3 Setpoint Value Adjustment by Current Signal	18
6.4 Digital Presetting of Setpoint Values	18
6.5 Setpoint Value Adjustment by Pedal.....	18
6.6 Pneumatic Setpoint Adjusters.....	18
7 Control Unit DC 16.1 - 03 up to DC 40.1 - 03	19
7.1 Specification.....	19
7.2 Measurements.....	20

8 Actuators	21
8.1 Design and Mode of Operation	21
8.2 Installation	22
8.3 Specification	23
8.4 Measurements	25
9 Regulating Linkage	26
9.1 Length of Lever Arm	26
9.2 Order Specification for Lever Arm	26
9.3 Connecting Linkage.....	26
9.4 Linkage Adjustment for Diesel Engines.....	27
9.5 Linkage Adjustment for Carburettor Engines	28
10 Electric Connection	29
10.1 Connection of Shielding	29
10.2 Connection of Power Supply	30
10.3 Example of Connection for Generator Set with digital Accessories	32
10.4 Example of Connection for Generator Set with analogue Accessories.....	33
10.5 Example of Connection for Vehicle Operation	34
10.6 Example of Connection for Locomotive Operation with 16 Notches	35
10.7 Example of Connection for Locomotive Operation with Speed Setpoint via Current Signal	36
10.8 Example of Connection for Marine Operation with Master/Slave.....	37
10.9 Example of Connection for Marine Operation in single Operation	38
11 Harness	39
11.1 Cable Lengths	39
11.2 Plug Designations	40
12 Programming Possibilities	41
12.1 Programming by the Manufacturer	41
12.2 Programming with the Hand- Held Programmer 2	41
12.3 Programming by PC	41
12.4 Programming with User Masks	41
12.5 Transferring Data Sets	41
12.6 Assembly Line End Programming	42
13 Starting the Engine - Brief Instructions.....	43
14 Ordering Specifications	44
14.1 General	44
14.2 Cable Length	44
15 Figure List.....	47

16 Order Specifications for Manuals..... 48

1 Safety Instructions and Related Symbols

This publication offers wherever necessary practical safety instructions to indicate inevitable residual risks when operating the engine. These residual risks imply dangers to

persons
product and engine
environment.

The symbols used in this publication are in the first place intended to direct your attention to the safety instructions!



This symbol is to indicate that there may exist dangers to the engine, to the material and to the environment.



This symbol is to indicate that there may exist dangers to persons. (Danger to life, personal injury))



This symbol is to indicate that there exist particular danger due to electrical high tension. (Mortal danger).

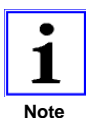

This symbol does not refer to any safety instructions but offers important notes for better understanding the functions that are being discussed. They should by all means be observed and practiced. The respective text is printed in italics.

The primary issue of these safety instructions is to prevent personal injuries!

Whenever some safety instruction is preceded by a warning triangle labelled “Danger” this is to indicate that it is not possible to definitely exclude the presence of danger to persons, engine, material and/or environment.

If, however, some safety instruction is preceded by the warning triangle labelled “Caution” this will indicate that danger of life or personal injury is not involved.

The symbols used in the text do not supersede the safety instructions. So please do not skip the respective texts but read them thoroughly!

In this publication the Table of Contents is preceded by diverse instructions that among other things serve to ensure safety of operation. It is absolutely imperative that these hints be read and understood before commissioning or servicing the installation.

1.1 Basic Safety Measures for Normal Operation

- The installation may be operated only by authorized persons who have been duly trained and who are fully acquainted with the operating instructions so that they are capable of working in accordance with them.
- Before turning the installation on please verify and make sure that
 - only authorized persons are present within the working range of the engine;
 - nobody will be in danger of suffering injuries by starting the engine.
- Before starting the engine always check the installation for visible damages and make sure it is not put into operation unless it is in perfect condition. On detecting any faults please inform your superior immediately!
- Before starting the engine remove any unnecessary material and/or objects from the working range of the installation/engine.
- Before starting the engine check and make sure that all safety devices are working properly!

1.2 Basic Safety Measures for Servicing and Maintenance

- Before performing any maintenance or repair work make sure the working area of the engine has been closed to unauthorized persons. Put on a sign warning that maintenance or repair work is being done.
- Before performing any maintenance or repair work switch off the master switch of the power supply and secure it by a padlock! The key must be kept by the person performing the maintenance and repair works.
- Before performing any maintenance and repair work make sure that all parts of engine to be touched have cooled down to ambient temperature and are dead!
- Refasten loose connections!
- Replace at once any damaged lines and/or cables!
- Keep the cabinet always closed. Access should be permitted only to authorized persons having a key or tools.

- Never use a water hose to clean cabinets or other casings of electric equipment!

1.3 Before Putting an Installation into Service after Maintenance and Repair Works

- Check on all slackened screw connections to have been tightened again!
- Make sure the control linkage has been reattached and all cables have been reconnected.
- Make sure all safety devices of the installation are in perfect order and are working properly!

2 General Remarks

HEINZMANN digital governors with control units DC 16.1-03 up to DC 40.01-03 constitute speed governors offering a wide range of functions.

In addition to speed regulation, the following functions are available:

a) Starting Fuel Flow Adjustment

When setting starting fuel flow, starting minimum fuel flow or starting maximum fuel flow are available as alternatives. If necessary, both can be dependent on temperature. Furthermore, variable starting fuel flow can be provided, by which starting fuel flow is increased automatically during start-up.

b) Speed Ramp

For applications in which speed is not supposed to respond as fast as possible to changes of setpoint values (e.g., locomotive operation), a speed ramp is available which according to requirements may be programmed separately for increasing or decreasing speed.

c) Fixed Fuel Limitation

For the stop-position and the maximum fuelling position "electric catches" can be provided. This will prevent the governor's thrust from affecting the terminal stops of the injection pump, etc.

d) Speed Dependent Fuel Limitation

For variable speed governors, there is provided an option of programming speed dependent limit curves. Thus, for any speed, torque can be reduced as is permissible for the engine or desired by the user.

e) Boost Pressure Dependent Fuel Limitation

For turbocharged engines, fuelling can be reduced to achieve smokeless operation in case of missing boost pressure (e.g., starting or load change). The respective limit curves can be programmed accordingly.

f) Idling and Maximum Speed Control

For vehicle application, the governor can be made to operate as an idling and maximum speed controller. In addition, one fixed intermediate speed is available, e.g., for an application combining driving and stationary mode (e.g., generator at power take-off). If necessary, a

change-over switching of the droop can be provided, i.e., during stationary operation also droop zero is possible

g) Temperature Dependent Idling Speed

For low temperatures, the engine can be run at some higher idling speed. With the engine warming up, idling speed is reduced to its normal value.

h) Oil Pressure Monitoring

For the purpose of oil pressure monitoring, speed/pressure dependent limit curves can be provided. If oil pressure is too low, an alarm is given; if oil pressure continues to drop, the engine is shut down.

i) Load Regulation System

For diesel-electric locomotive operation, a load regulation system can be provided, by which generator output is regulated in dependence on speed resp. load.

j) Anti Stick Slip Device

For locomotive operation, an anti stick slip device can be provided.

k) Accessories

Accessories such as synchronizing units, load measuring units, disturbance variable compensation units can be connected via a CAN-Bus within the control unit. The CAN-Bus may also be used to implement load distribution by equal fuelling (e.g., two engines on one gear).

l) Output Signals

For speed and actuator travel, proportional signals are available in the range of 4–20 mA. They can be used for purposes of display or for further processing (e.g., switches).

m) Operating Data Storage

On request, operating data storage can be provided, by which in cases of disturbances and failures the causes may be traced back even at some later time.

Furthermore, if errors occur at the sensors or within the control system, an alarm is given.

**Note**

When selecting and determining the functions, it has to be ascertained whether the hardware equipment suffices with respect to the total range of functions.

3 Mode of Operation

The actual speed of the engine is read by a pulse pickup from a cog wheel, preferably from the starter gear. The microprocessor (CPU) of the control unit compares the actual speed with the preset value. If differences are stated, the new actuator signal is calculated by the CPU and transmitted to the actuator via the output stage. Feedback from the actuator indicates the current position of the output shaft thus allowing optimum signal adjustment by the CPU.

As the governor comprises an I-fraction and as for any load level the speed is permanently compared with a fixed preset value, speed can be kept constant also in steady state, i.e., droop is zero.

For applications requiring droop, the speed related to the respective fuelling is calculated by the CPU and entered as correction of the setpoint value.

During standstill, a particular circuit ensures that only the current of the control unit is received by the governor, but no current flows to the actuator motor.

4 Block Diagram of the Digital Governor DG 16.1 - 03 up to DG 40.1 - 03

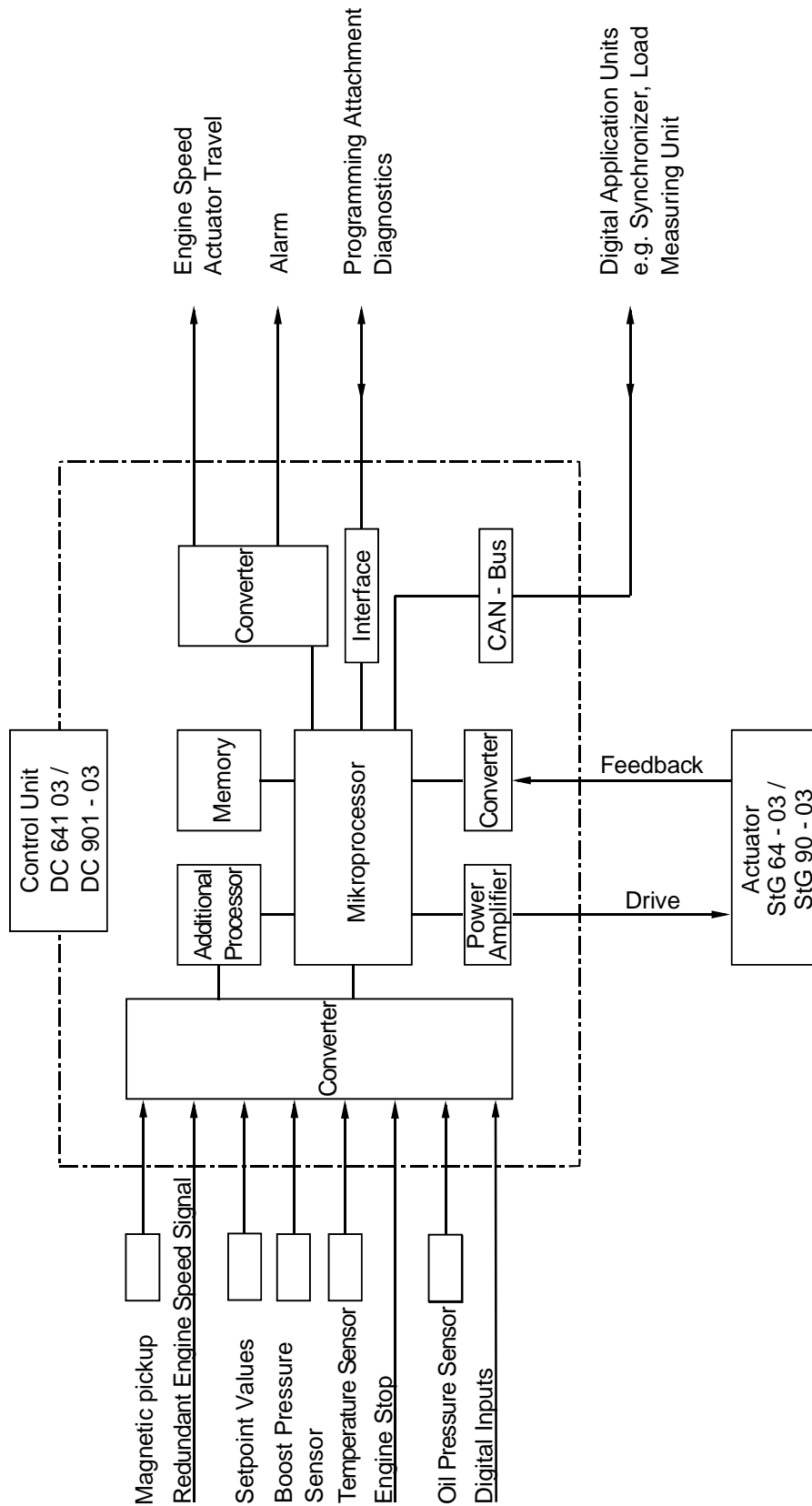

Figure 1: Blockdiagram DG 16.1 - 03 up to DG 40.1 - 03

5 Sensors

5.1 Overview

Sensor	Speed	Coolant Temperature	Oil Pressure	Boost Pressure
HZM Designation	IA ..	TS 01-28-PT1000	DSO 01-6 DSO 01-10 DSO 01-16	DSL/G 0..-2 DSL/G 0..-5 DSL/G 0..-10
Connection	SV 6-IA-2K 2 pole	SV 6-IA-2K 2 pole	DIN 43650 A 2 Line System	DIN 43650 A 2 Line System
Measuring Procedure	inductive, active	PT1000, passive	active	active
Measuring Range	50...6.000 Hz	-50...+150°C	0...6 bar 0...10 bar	0...2 bar 0...5 bar 0...10 bar
Supply Voltage Range		passive	10...34 V DC	12...36 V DC
Output Signal Range	0...10 V AC	ca. 700...1500 Ohm	4...20 mA	4...20 mA
Operating Temperature Range	-55...+120°C	-50...+150°C	-25...+125°C	-40...+100°C

In order to ensure maximum flexibility with regard to the sensors, the minimum/ maximum current values and the measuring ranges of the pressure and temperature sensors have been provided programmable.

5.2 Magnetic Pickup IA ...

5.2.1 Technical Datas

Operating principle	inductive sensor
Distance from sensing gear	standard 0.5 to 0.8 mm with IA 22.. and IA 23.. 2.5 to 3 mm
Output	0 V .. 10 V AC
Signal form	Sine (depending on tooth shape)
Resistance	approx. 52 Ohm, with IA 22.. and IA 23.. approx. 130 Ohm
Temperature range	-55°C up to +125°C
Protection grade	IP 55
Vibration	< 10g, 10 .. 100 Hz
Shock	< 50g, 11 ms half sine wave
Corresponding plug	SV 6 - IA - 2K (EDV- No.: 010-02-170-00)

5.2.2 Installation

The installation of the pickup has to be arranged in such a way as to obtain a frequency as high as possible. Normally, the HEINZMANN digital governors DG 16.1 - 03 up to DG 40.1 - 03 are designed for a maximum frequency of 6.000 Hz. The frequency (by Hz) is calculated according to the formula:

$$f \text{ (Hz)} = \boxed{}$$

$$z = \text{number of teeth on the pickup wheel}$$

Example:

$$n = 500$$

$$z = 80$$

$$f = \boxed{} = 666.67 \text{ Hz}$$

It should be taken care that the speed can be measured by the pulse pickup without any bias. For best results therefore, the speed pickup should take the engine speed from the crankshaft. A suitable position for this is, e.g., the starter gear (but not the injection pump wheel).

The pickup gear must consist of magnetic material (e.g., steel, cast iron).

5.2.3 Tooth Profile

Any tooth profile is admissible. The top width of the tooth should be 2.5 mm minimum, the gap and the depth of the gap at least 4 mm (8 mm at IA 22 - 76 and IA 23 - 102). For index plates the same dimensions are valid.

Due to tolerances, a radial arrangement of the magnetic pickup is preferable.

5.2.4 Clearance for IA 02 - 76 up to IA 13 - 102

The distance between the magnetic pulse pickup and the tooth top should range from 0.5 to 0.8 mm. (It is possible to screw in the magnetic pickup till it touches the tooth and then unscrew it for about half a turn.)

5.2.5 Clearance for IA 22 - 76 and IA 23 - 102

The distance between the magnetic pulse pickup and the tooth top should range from 2.5 to 3 mm. (It is possible to screw in the magnetic pickup till it touches the tooth and then unscrew it for about two turns.)

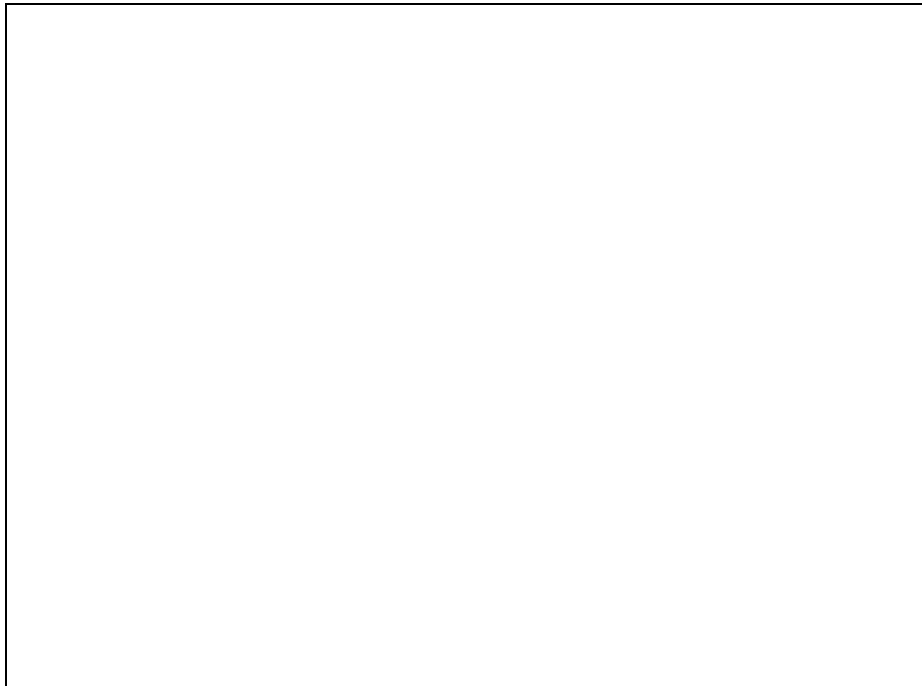

Figure 2: Clearance of Pickup

5.2.6 Mounting Measurements

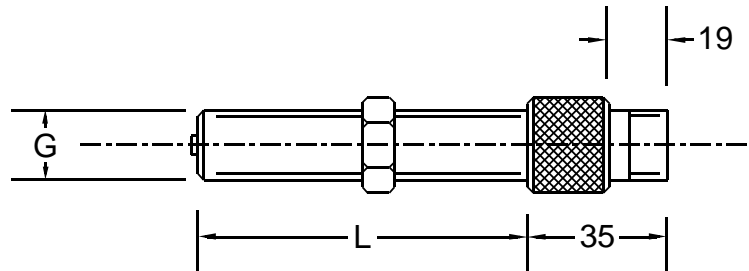

Figure 3: Magnetic Pickup

Measures Type	Thread Length L (mm)	Thread Size G	Remarks
01 - 38	38	M 16 x 1,5	appropriate plug SV6-IA-2K
02 - 76	76	M 16 x 1,5	
03 - 102	102	M 16 x 1,5	
11 - 38	38	5/8"-18UNF-2A	
12 - 76	76	5/8"-18UNF-2A	
13 - 102	102	5/8"-18UNF-2A	
22 - 76	76	M 24 x 1,5	
23 - 102	102	M 24 x 1,5	

Ordering specification, e.g. IA 02-76.

5.2.7 Redundant Speed Signal

If precautions are to be taken with regard to failures of the pulse pickup, a second pulse pickup can be connected to the control unit. In case that an electric generator with terminal W is available, this signal may be used for emergency operation as well as any other signal of a tachogenerator.

In case of a failure on pulse pickup 1, the governor automatically switches over to the redundant speed signal and gives an alarm.

5.3 Cooling Medium Temperature Sensor TS 01 - 28 - PT 1000

Measuring range	-50°C up to +150°C
Precision	±1.5°C
Resistance at 25 °C (R25)	1000 Ohm ±0.5 %
Maximum operating voltage	5 V
Maximum operating current	3 mA
Recommended operating current	approx 1mA
Time constant in fluids	approx. 13 seconds
Admissible temperature range of connector socket	-40°C up to +105°C
Protection grade	IP 65
Vibration	< 20 g, 10 - 300 Hz
Shock	< 50 g, 11 ms half-sine wave
Tightening torque	50 Nm ±15 %
Connector	SV 6 - IA - 2K (EDV- No.: 010 02 170 00)
EDV-No.:	600-00-053-00

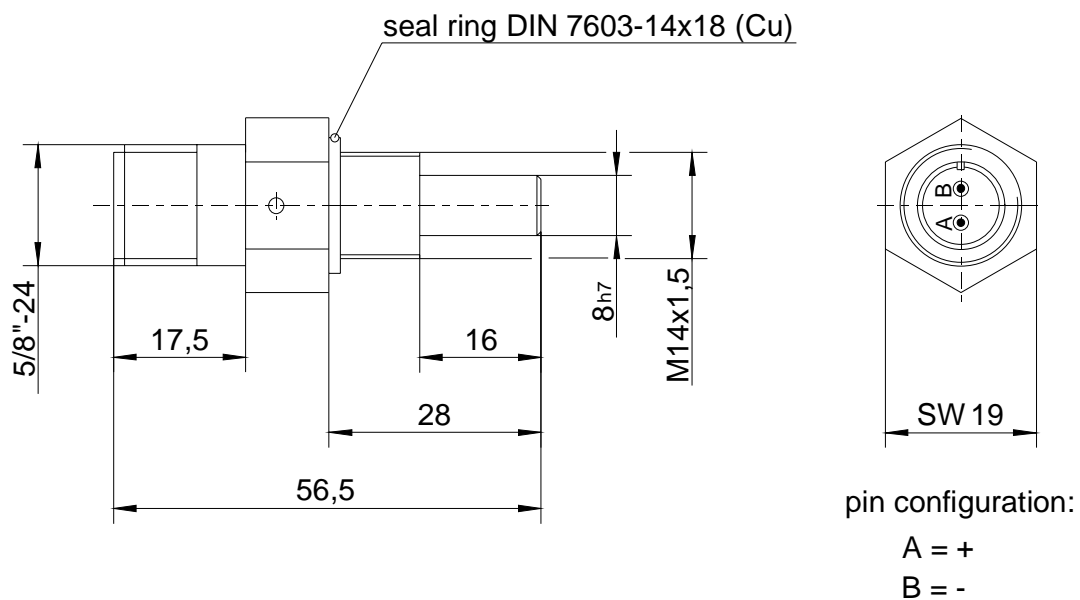

Figure 4: Temperature Sensor TS 01 - 28 - PT 1000

5.4 Pressure Sensors

5.4.1 Oil Pressure Sensor

Measuring range	0 - 6 bar or 0 - 10 bar
Over pressure	15 bar resp. 20 bar
Supply voltage	10 - 34 V DC
Output signal	4 - 20 mA
Storage temperature	-25°C up to +85°C
Ambient temperature	-25°C up to +85°C
Oil temperature	-25°C up to +125°C
Protection grade	IP 65
Vibration	< 20 g, 10 - 300 Hz
Shock	< 50 g, 11 ms half-sine wave
Tightening torque	max. 25 Nm
Connection	DIN 43650-A, 2-line system

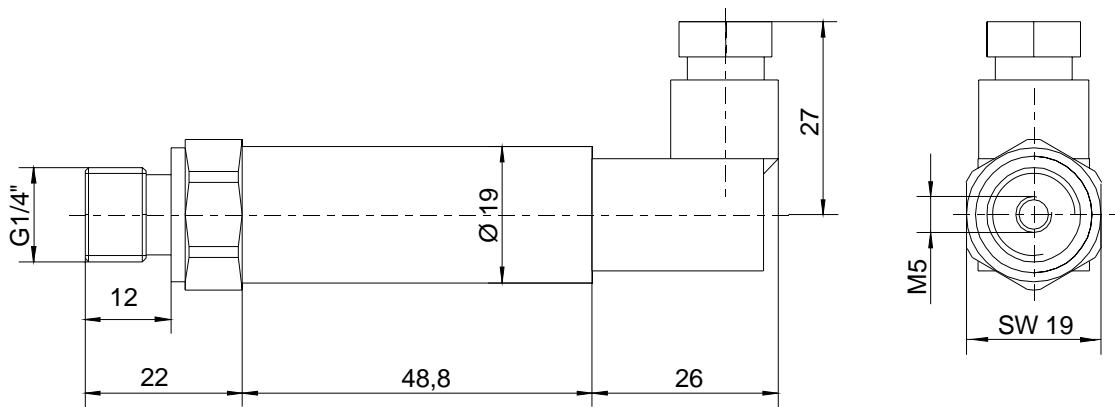

Figure 5: Oil Pressure Sensor

Pressure Sensor	EDV- No.	Max. Operating Pressure (bar)
DSO 01 - 6	600-00-058-00	6
DSO 01 - 10	600-00-058-01	10

5.4.2 Boost Pressure Sensors

The boost pressure sensors are also available in an additional housing with terminal strip.

Measuring range	0 - 2 bar, 0 - 5 bar or 0 - 10 bar
Over pressure	4 bar resp. 10 bar resp. 16 bar
Supply voltage	12 - 36 V DC
Output signal	4 - 20 mA
Storage temperature	-55°C up to +100°C
Ambient temperature	-40°C up to +100°C
Protection grade	IP 65
Vibration	< 2 g, 5 - 500 Hz
Shock	< 50 g, 11 ms half-sine wave
Connection	DIN 43650-A or terminal strip, 2-line system

5.4.2.1 Boost Pressure Sensor with Plug

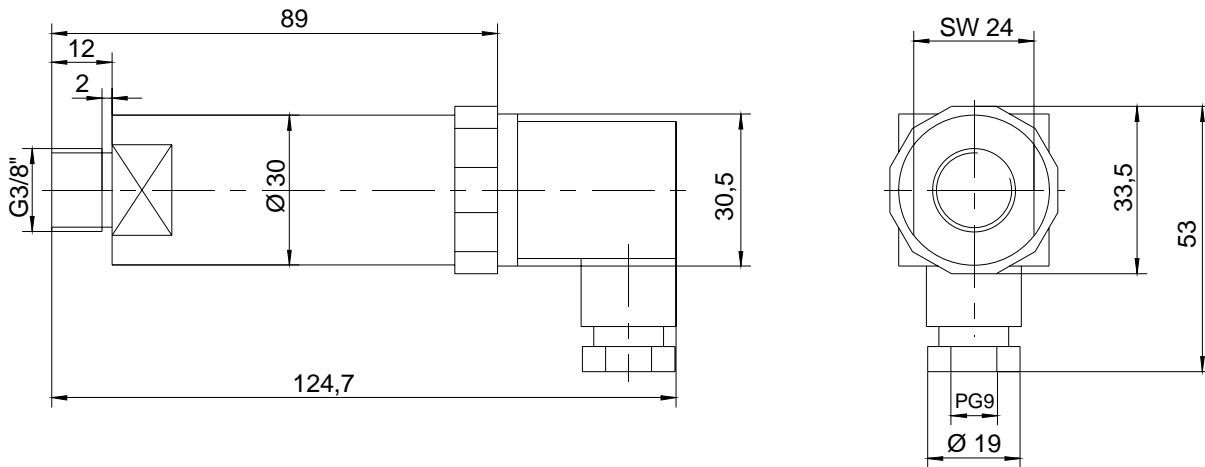

Figure 6: Boost Pressure Sensor with Plug

Boost Pressure	EDV- No.	Max. Operating Pressure (bar rel.)
DSL 01 - 2	600-00-057-00	2
DSL 01 - 5	600-00-057-01	5
DSL 01 - 10	600-00-057-02	10

5.4.2.2 Boost Pressure Sensor with Housing and Terminal Strip

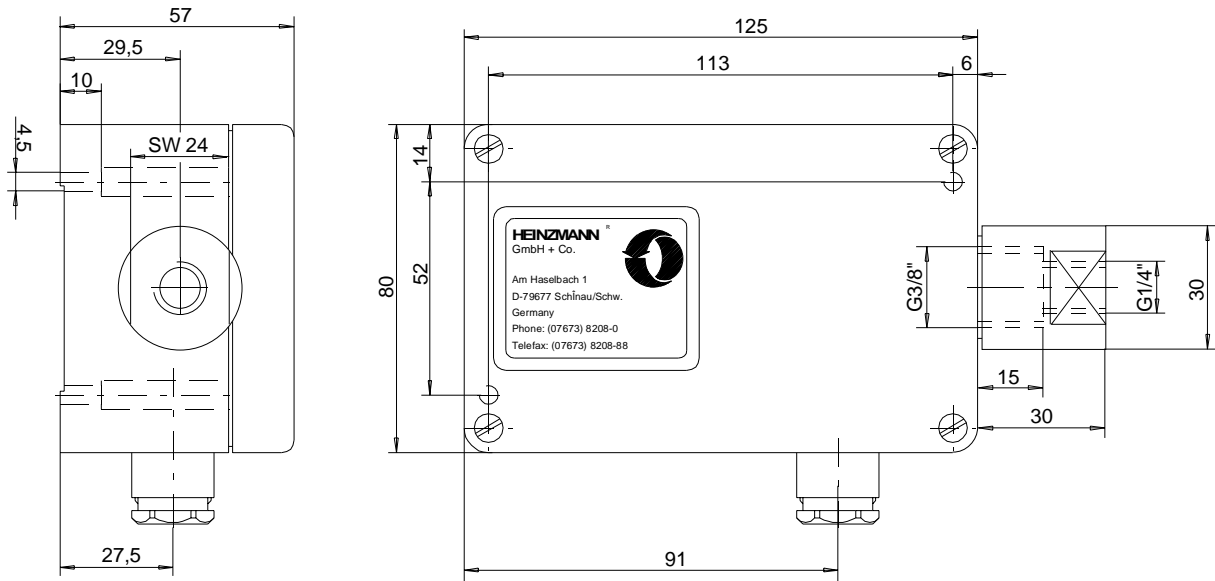

Figure 7: Boost Pressure Sensor with Housing

Pressure Sensor	EDV- No.	Max. Operating Pressure (bar rel.)
DSG 04 - 2	600-00-056-00	2
DSG 04 - 5	600-00-056-01	5
DSG 04 - 10	600-00-056-02	10

6 Speed Setpoint Adjusters

Dependent on particular applications, a series of setpoint adjusters are available for the HEINZMANN Digital Controls.

6.1 Setpoint Potentiometer SW 01 - 1 - b (1 turn)

Displacement angle	approx. 312°
Resistance	5 kOhm
Temperature range	-55°C to + 120°C
Protection grade	IP 00

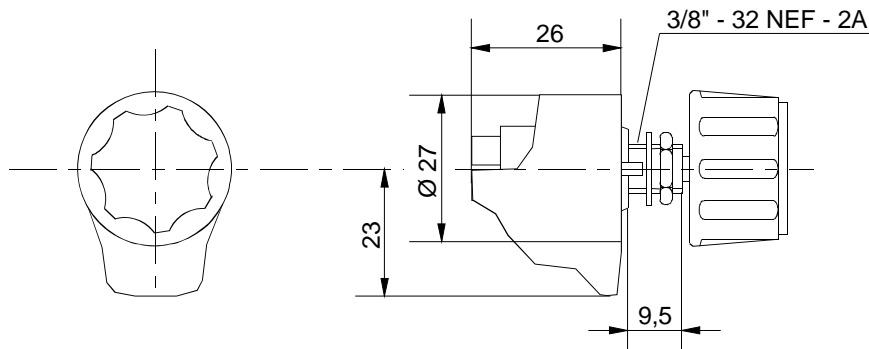

Figure 8: Potentiometer SW 01 - 1 - b

6.2 Setpoint Potentiometer SW 02 - 10 - b (10- turn)

Displacement angle	10 turns
Resistance	5 kOhm
Temperature range	-55°C to + 120°C
Protection grade	IP 00

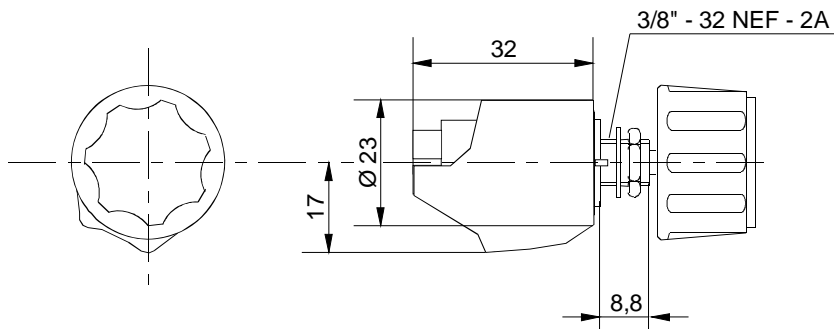

Figure 9: Potentiometer SW 02 - 10 - b

On request, the potentiometers, as specified under 6.1 and 6.2, can be supplied with analogue adjustment knob with lock in place of the standard rotating knob. In this case, ordering specification is SW...-m.

Equally, instead of the knob a clamping fixture can be installed. Ordering specification is to be changed to SW ...-k.

6.3 Setpoint Value Adjustment by Current Signal

For the speed setpoint value a current signal of 4–20 mA can be directly connected to the control unit. If the signal fails, the governor will set minimum speed according to the 4 mA value or a programmable substitute value.

6.4 Digital Presetting of Setpoint Values

A 4 bit binary coded digital input for 16 speed levels from n_{\min} to n_{\max} can be directly connected to the control unit.

6.5 Setpoint Value Adjustment by Pedal

This unit is basically an angular position transducer that translates a foot pedal into a proportional current or voltage for 0 - 45° rotation. The resulting output can be used for speed setting. For more information refer brochure E 83 005 - e.

6.6 Pneumatic Setpoint Adjusters

For pneumatic setpoint adjustment are the boost pressure sensors usable. For more informations of the sensors refer to chapter 5.5.2.

7 Control Unit DC 16.1 - 03 up to DC 40.1 - 03

7.1 Specification

Operating voltage	24 V DC
max. voltage	35 V DC
min. voltage	18 V DC
Maximum ripple voltage	maximum 10 % with 100 Hz
Permissible voltage dip at Maximum voltage of actuator	maximum 10 % in control device
Fuse protection of governor	
electronic	3 A
power stage	16 A
Current consumption	approx. 200 mA + current of actuator
Storing temperature	- 55 °C to + 85 °C
Operating ambient temperature	- 40 °C to + 70 °C
Humidity	up to 98 %
Control frequency	200 to 6.000 Hz
Steady state variation	± 0.25 %
Speed variation due to temperature for Frequency greater than 500 Hz between -40 °C and + 70°C	± 1 %
Protection grade	IP 55
Weight	approx. 3 kg

7.2 Measurements

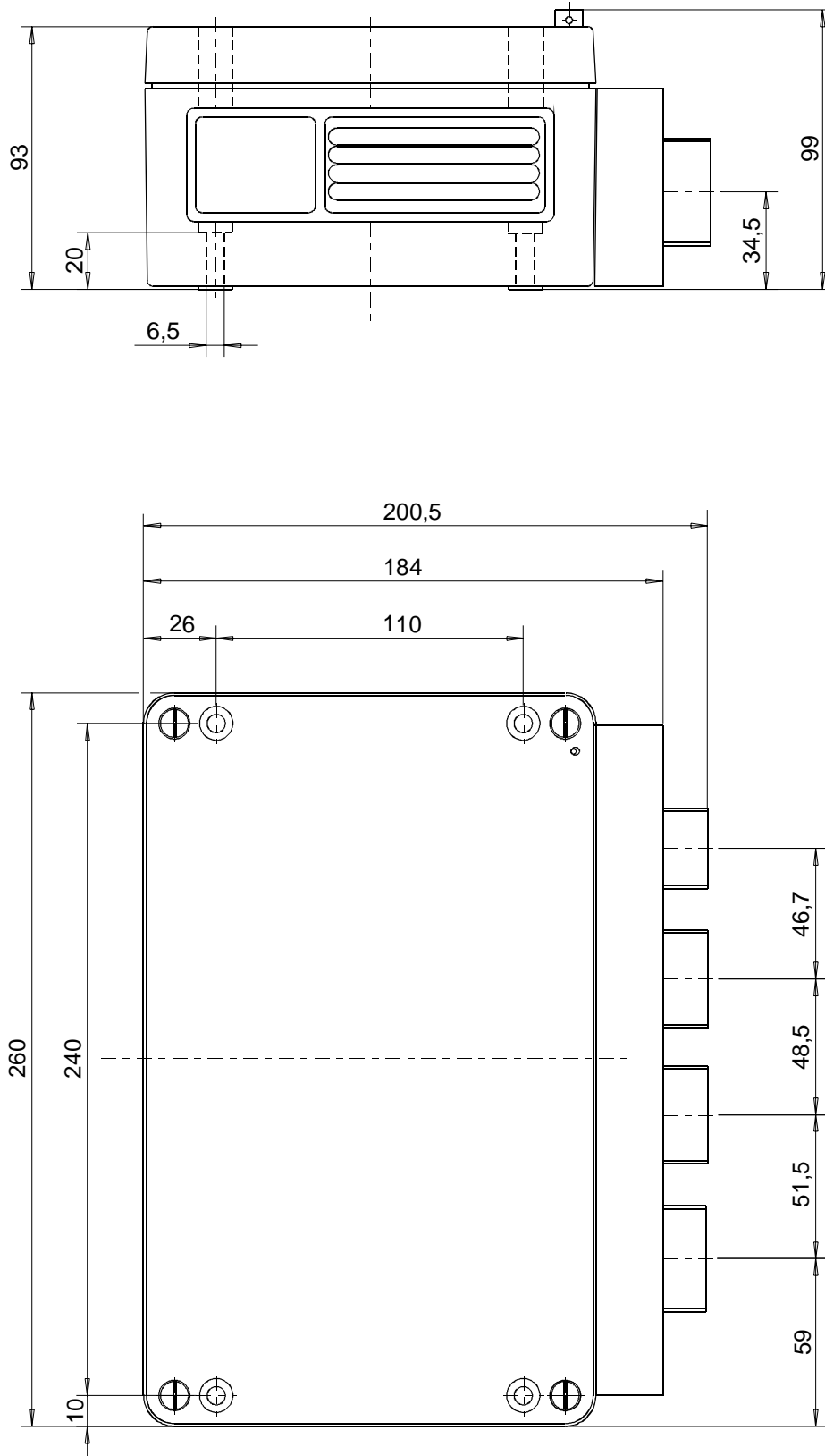

Figure 10: Control Unit DC 16.1 - 03 up to DC 40.1 - 03

8 Actuators

8.1 Design and Mode of Operation

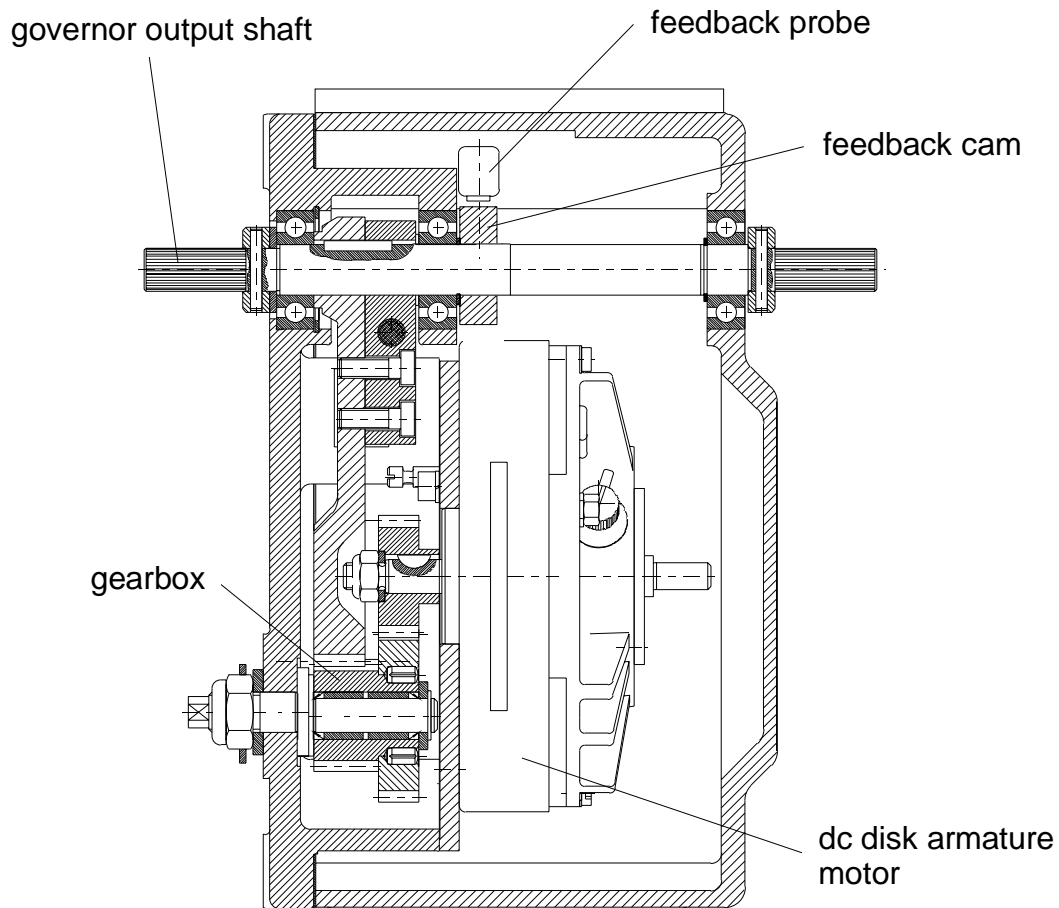

Figure 11: Sectional Drawing of Actuator

The actuator torque is generated by a DC disk armature motor and transmitted to the governor output shaft by way of a gearbox.

The use of special materials and long-time lubricants assures maintenance-free operation and long working life of the actuators.

A feedback cam is mounted on the governor output shaft which is scanned contactlessly by a probe, thus transmitting the precise position of the output shaft to the control unit.

If the actuator strikes against a stop, as may occur, e.g., under parallel mains operation or may be caused by engine overload or cylinder failure, the current limitation will take effect after approx. 20 seconds; by this the current to the actuator is reduced to a value that cannot harm the motor.

Altogether, this type of actuator provides the following advantages:

- High regulation power working in both directions.
- Extremely low current consumption during steady state and relatively low current consumption on change of load.
- Indifference to slow voltage changes of the supply; abrupt voltage changes cause governor disturbances.

8.2 Installation

The actuator must be mounted firmly on the engine by means of reinforced brackets. Unstable arrangements, as caused by weak bracket material or missing stiffenings, have to be avoided by all means; they are bound to intensify vibrations, which will lead to premature wear of the actuator and the connecting linkage!

Generally any mounting position is possible; however, the actuators should not be mounted with the plug connection pointing straight upward.

8.3 Specification

	StG 16 - 01	StG 30- 01
Efective rotation at the output shaft	42°	42°
Max. torque at the governor output shaft	approx. 15 Nm	approx. 28 Nm
Torque in steady state condition	approx. 5 Nm	approx. 9 Nm
Response time 0-100 % without load	approx. 120 ms	approx. 170 ms
Current consumption of whole governor		
maximum current	approx. 5 A	approx. 5 A
safe current in steady state condition	approx. 1.7 A	approx. 1.7 A
Storage temperature	-55°C up to +110°C	-55°C up to +110°C
Ambiente emperature in operation	-25°C up to +90°C	-25°C up to +90°C
Ambiente temperature special version	-40°C up to +90°C	-40°C up to +90°C
Humidity	up to 98 %	up to 98 %
Protection grade	IP 55	IP 55
Weight without base	approx. 12.3 kg	approx. 12.3 kg
Weight of base	approx. 1.3 kg	approx. 1.3 kg

	StG 40 - 01
Efective rotation at the output shaft	42°
Max. torque at the governor output shaft	approx. 44 Nm
Torque in steady state condition	approx. 14.5 Nm
Response time 0-100 % without load	approx. 190 ms
Current consumption of whole governor	
maximum current	approx. 5 A
safe current in steady state condition	approx. 1.7 A
Storage temperature	-55°C up to +110°C
Ambiente emperature in operation	-25°C up to +90°C
Ambiente temperature special version	-40°C up to +90°C
Humidity	up to 98 %
Protection grade	IP 55
Weight without base	approx. 12.3 kg
Weight of base	approx. 1.3 kg

8.4 Measurements

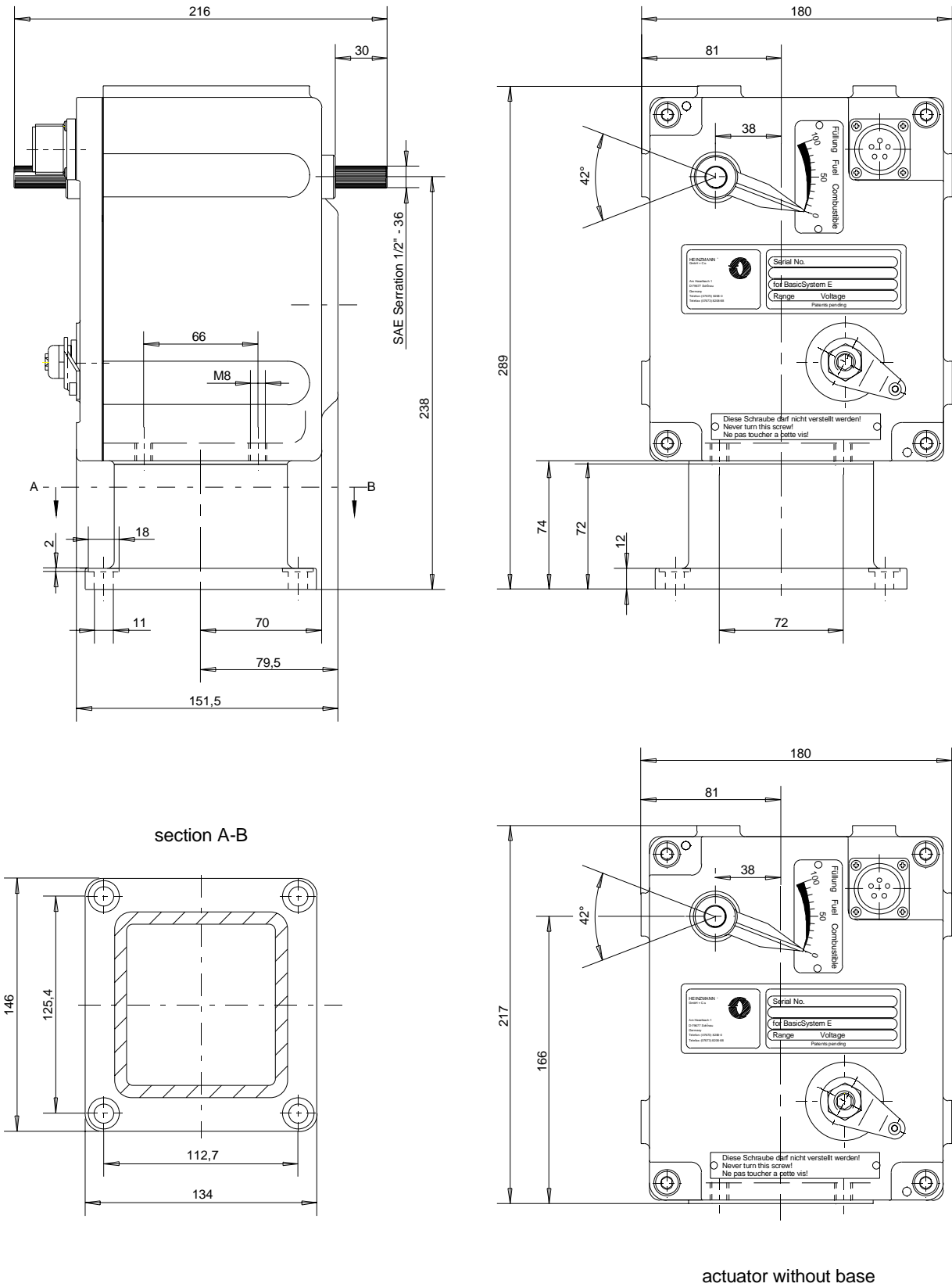

actuator without base

Figure 12: Actuators StG 16 - 01, StG 30 -01 and StG 40 - 01

9 Regulating Linkage

9.1 Length of Lever Arm

The length of the lever arm is determined in such a way that approx. 90 % of the governor output shaft adjustment angle can be used. Based on this, the rack length L of governors with 36° adjustment angle is calculated as $L = 1.8 a$, "a" being the travel distance of the injection pump or the carburettor.

9.2 Order Specification for Lever Arm

Please order RH 16 - 01 (EDV- No.: 504 170 02 00)

9.3 Connecting Linkage

The connecting linkage from the governor to the injection pump or the carburettor should be length-adjustable and have a (pressure or tension) elastic link. If possible, joint rod heads in accordance with DIN 648 should be used as connecting links. The linkage must operate easily and without clearance.

In case of friction or backlash in the linkage connecting actuator and injection pump resp. throttle valve no optimal control is possible.

9.4 Linkage Adjustment for Diesel Engines

The length of the connecting linkage is adjusted in such a way that with the governor in stop position the injection pump is set to 0 - 2 fuel marks. (Travel of the injection pump control rack is limited by the governor.)

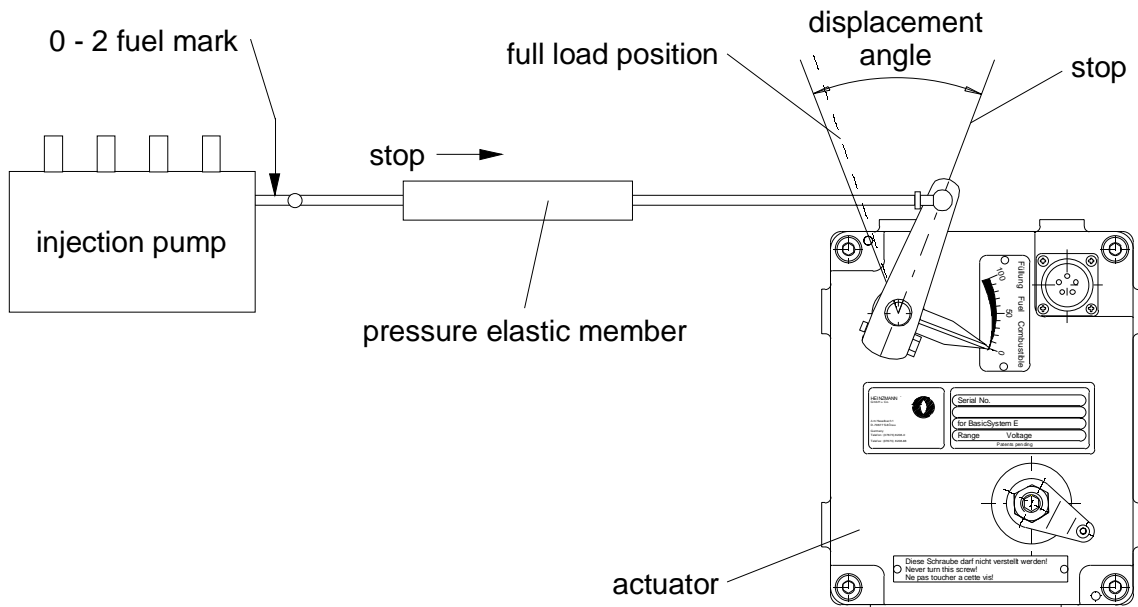

Figure 13: Linkage for Diesel Engines

The resistance of the pressure elastic link is overcome when the control rack has reached the full load stop and the speed continues to decrease (overload). Furthermore, the elastic link is overcome when stopping via the emergency switch.

9.5 Linkage Adjustment for Carburettor Engines

For carburettor or gas engines, the length of the connecting linkage is adjusted in such a way that with the governor in full load position the throttle valve is completely open. In idling speed position, the elastic link must be slightly overcome. This allows adjustment of the idle screw without changing the governor adjustment.

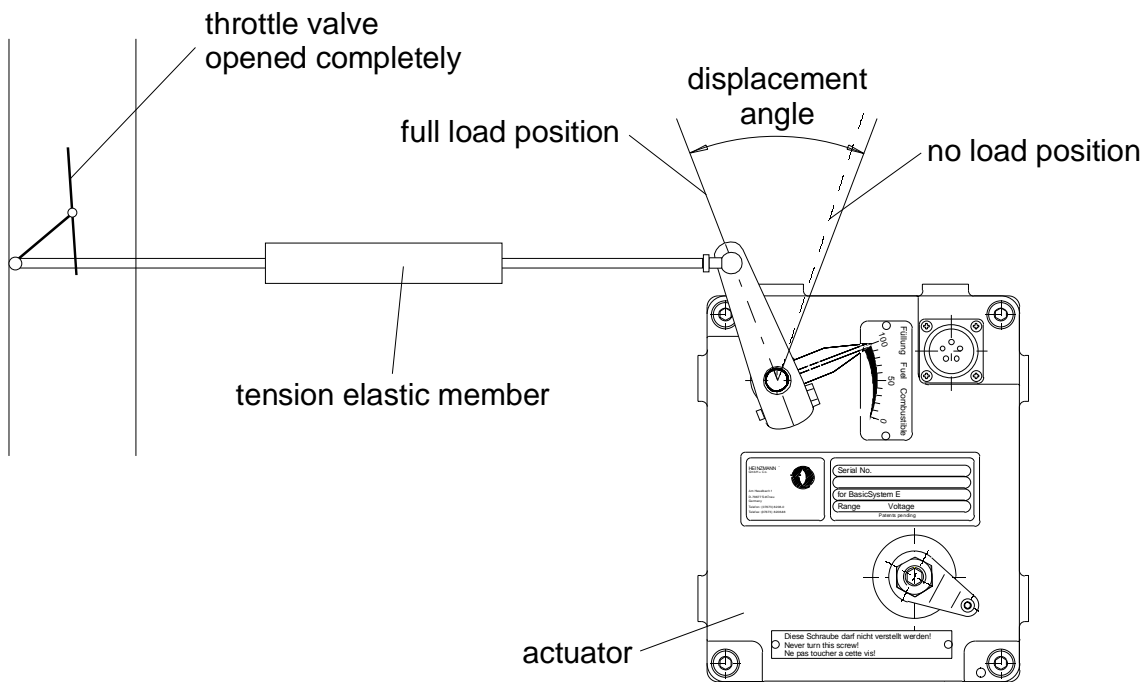
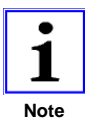

Figure 14: Linkage for Gas Engines



If carburettor or injection pump are to the right of the governor as opposed to their position on the drawings, then the direction of motion of the elastic link must also be reversed.

10 Electric Connection

10.1 Connection of Shielding

To avoid elektromagnetic influences it is necessary to connect cable shields at both ends. This includes shielding from control housing to sensors, from control housing to potentiometers, from control housing to actuator and from control housing to accessory units. If there is a potential difference between the control housing and any of these other componets, to avoid currents via the shielding it is necessary to run a separate wire from the control housing to each of these components.

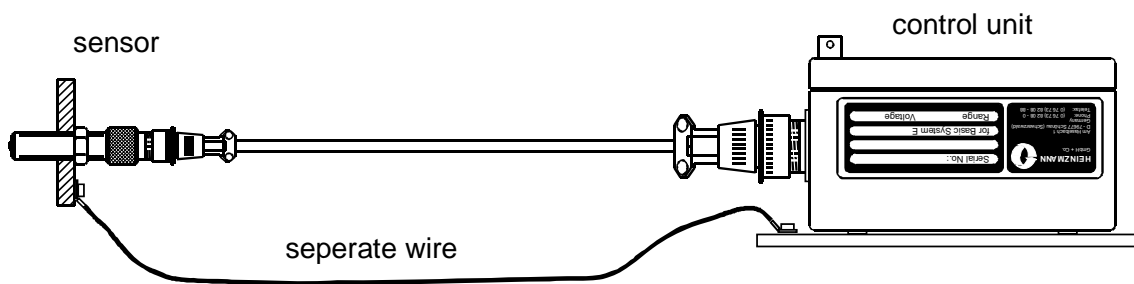

Figure 15: Connection of seperat Wire

At cable ends without plugs (e.g. terminal strip or pins) the shielding must be connected at the housing near the contacts.

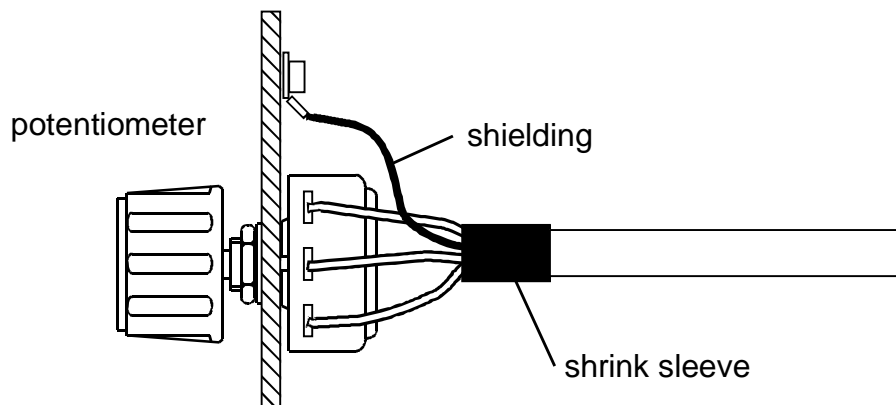

Figure 16: Shield Connection without Plug

In case of a plug connection the shielding is jamed in the strain relief of the plug.

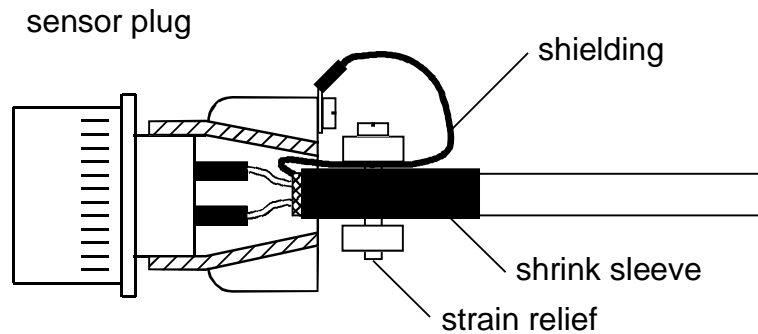

Figure 17: Shield Connection in the Plug

10.2 Connection of Power Supply

Inappropriate choice of power supply or insufficient battery capacitance or incorrect connection of the power supply line or too small cable sizes of the feed line and the motor line of the actuator are bound have an adverse effect upon the performance of the speed governor. In steady state operation, this will cause a heavy increase of current consumption and unnecessary vibration of the actuator drive. The high current consumption will in its turn lead to overheating of the actuator or the amplifier in the control unit, and the vibration will result in premature wear of the gear and bearing parts or of the linkage.



Note

In altogether, the lifetime of the control system is distinctly reduced by the errors described above.

The following figure shows both a wrong and a correct cabling:

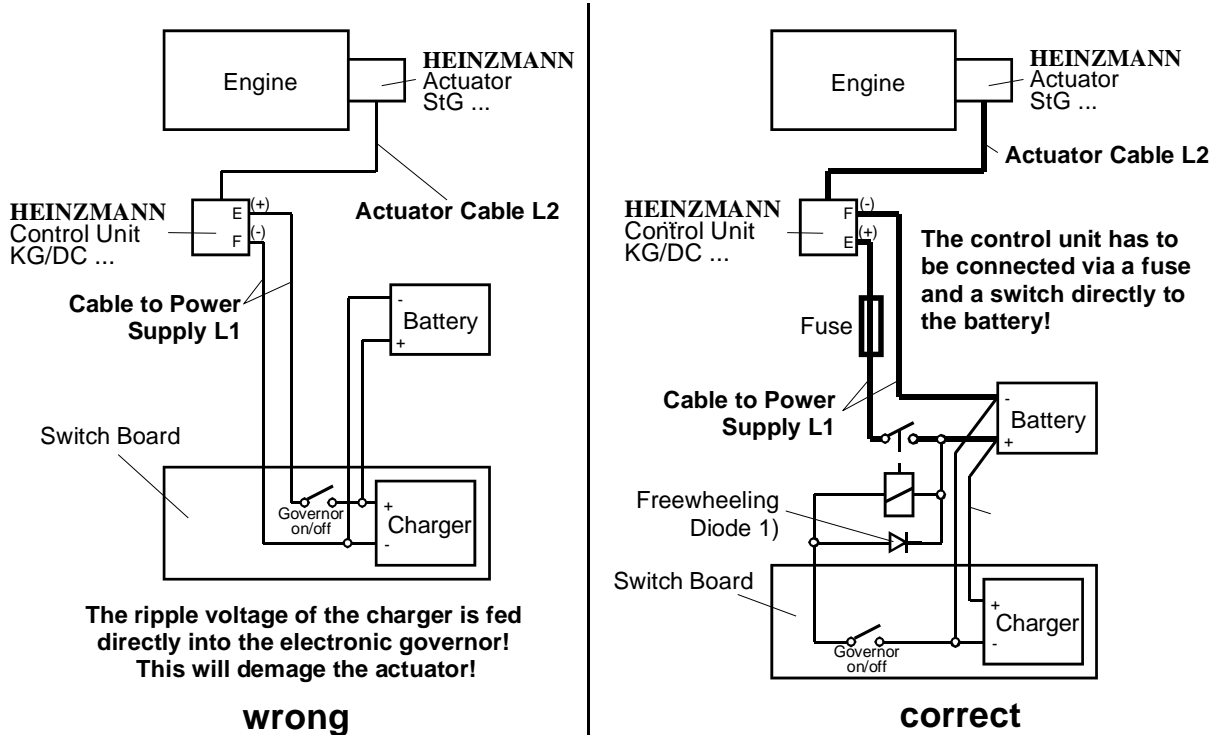

1) Coils (e.g. stopping solenoid, gas valve) have to be equipped with a protective circuit to eliminate high inductance voltages. Diode type e.g. 1N4002

Figure 18: Correct Connection of Power Supply



Warning

If there are battery chargers with rapid charge mode installed in the plant, the rapid charge mode should no be used during operation.

If there is no battery provided, **it is absolutely necessary** that a three phase power supply or a **stabilized** one phase power supply with at least 24 V DC, 10 Amps output power **be used** as a power source.

HEINZMANN offers for the control system PRIAMOS I the power supply NG 01 and if an additional backup system is required, the power supply NG 01 + NSV 01 and NG 04. For more informations, refer to the separate manuals E 88 002-e and E 97 002-e.



Warning

The cable sizes and cable lengths described in the wiring diagrams must not be exceeded!

When power supply, battery and cabling have been correctly dimensioned, then on starting the engine or with the actuator operating at maximum current consumption (approx. 6.4 Amps), a drop of the supply voltage directly at the control unit of approx. 2 Volts maximum only will be admissible.

10.3 Example of Connection for Generator Set with digital Accessories

(Island parallel- and mains operation)

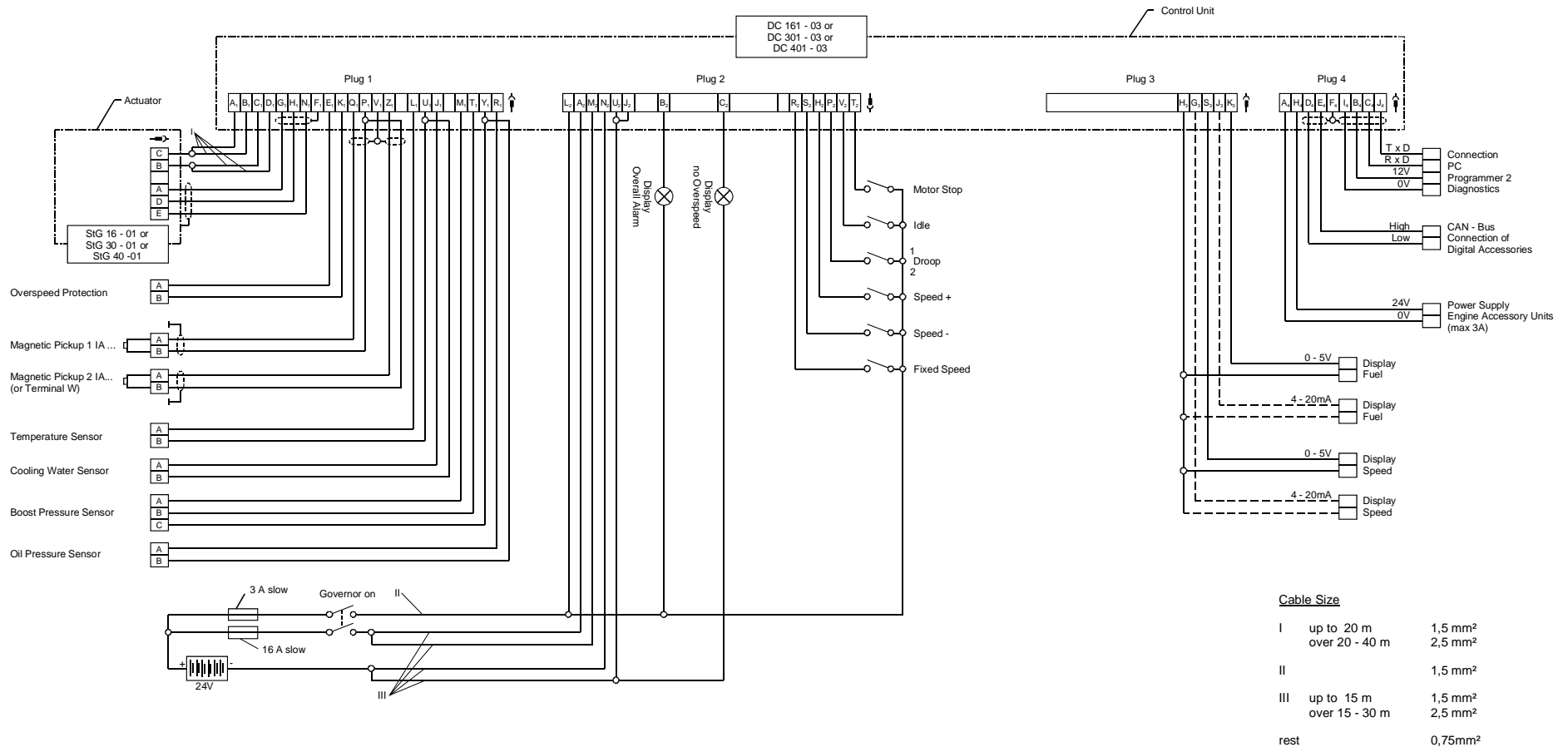

Figure 19: Connection for Generator Set with digital Accessories

10.4 Example of Connection for Generator Set with analogue Accessories

(Island parallel- and mains operation)

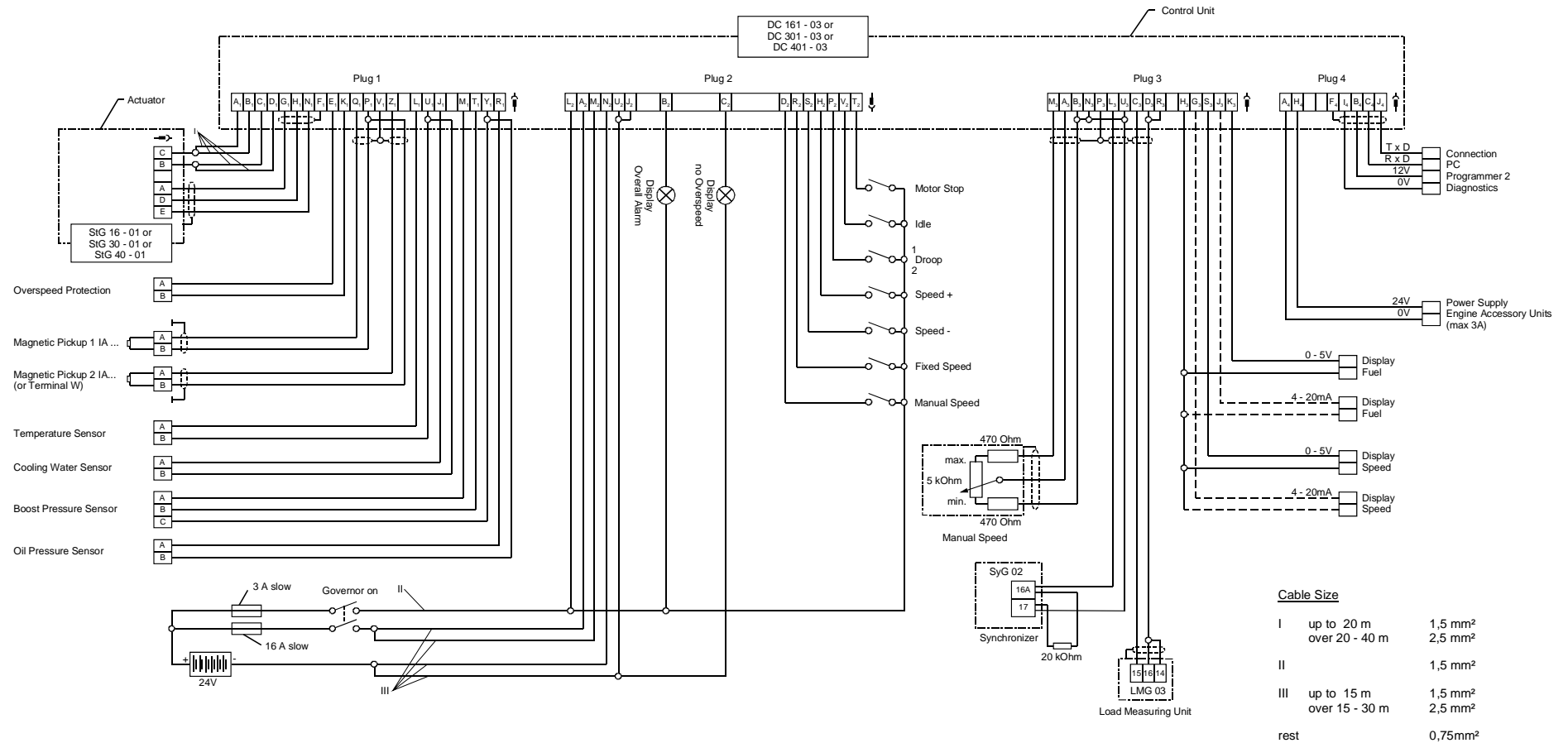

Figure 20: Connection for Generator Set with analogue Accessories

10.5 Example of Connection for Vehicle Operation

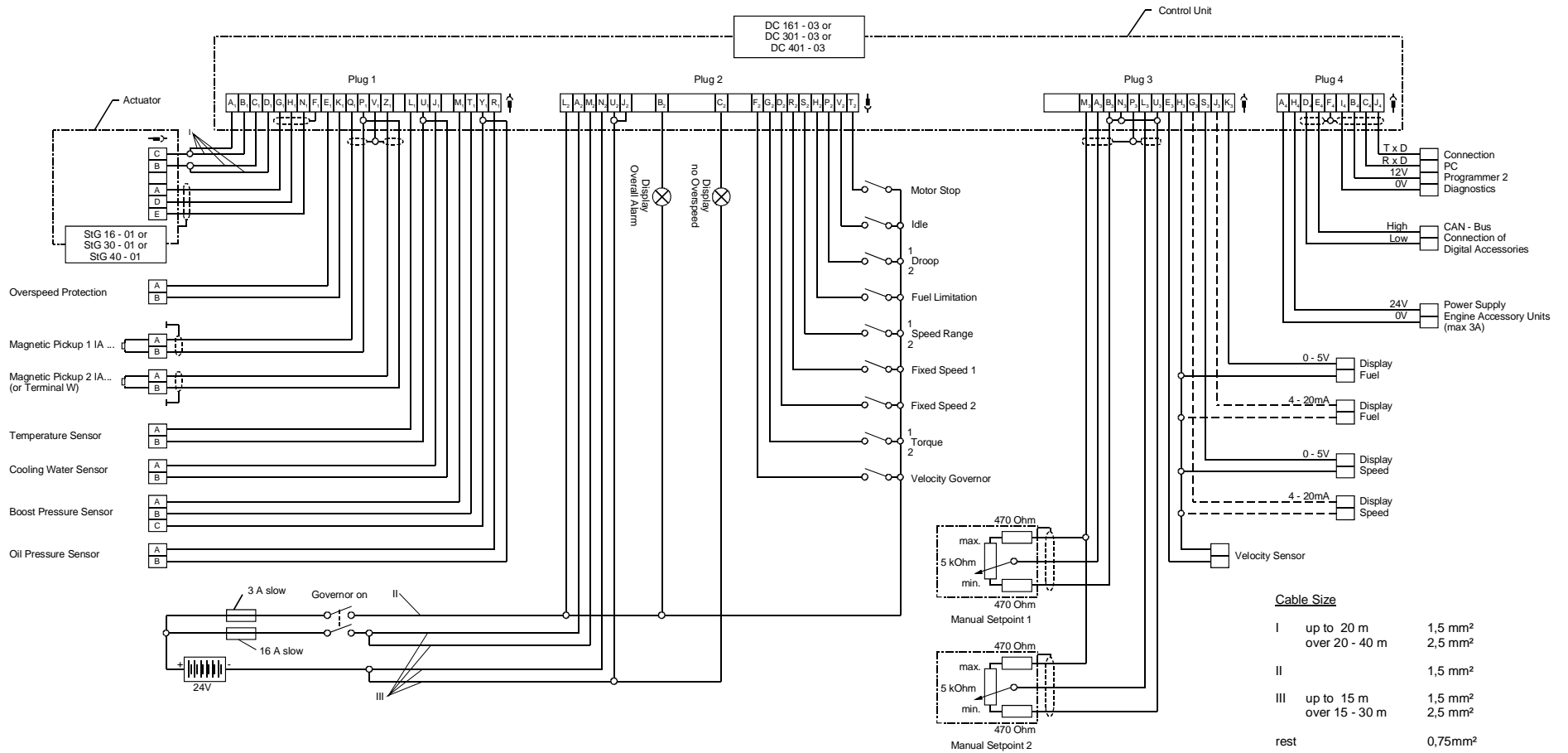

Figure 21: Connection for Vehicle Operation

10.6 Example of Connection for Locomotive Operation with 16 Notches

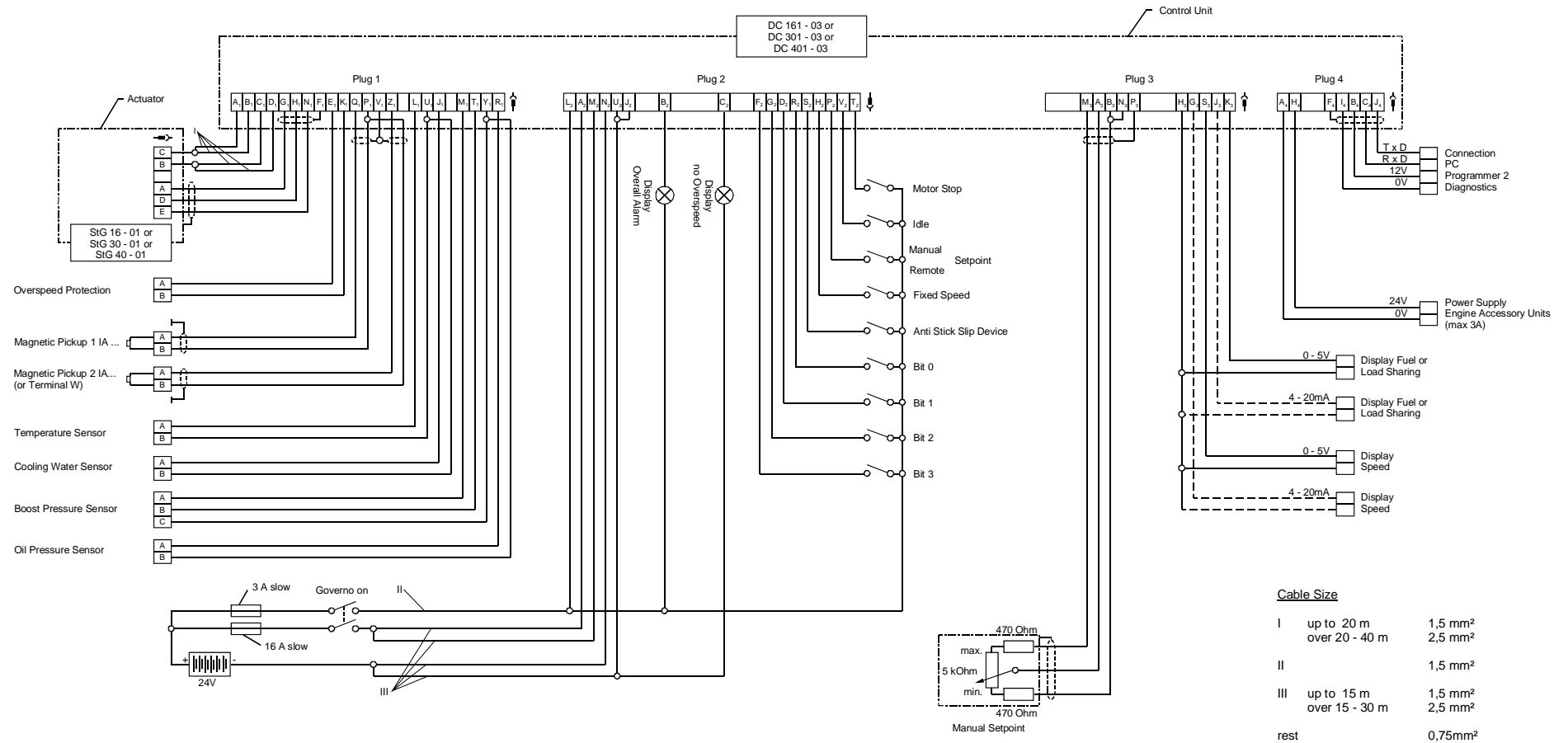

Figure 22: Connection for Locomotive Operation with 16 Notches

10.7 Example of Connection for Locomotive Operation with Speed Setpoint via Current Signal

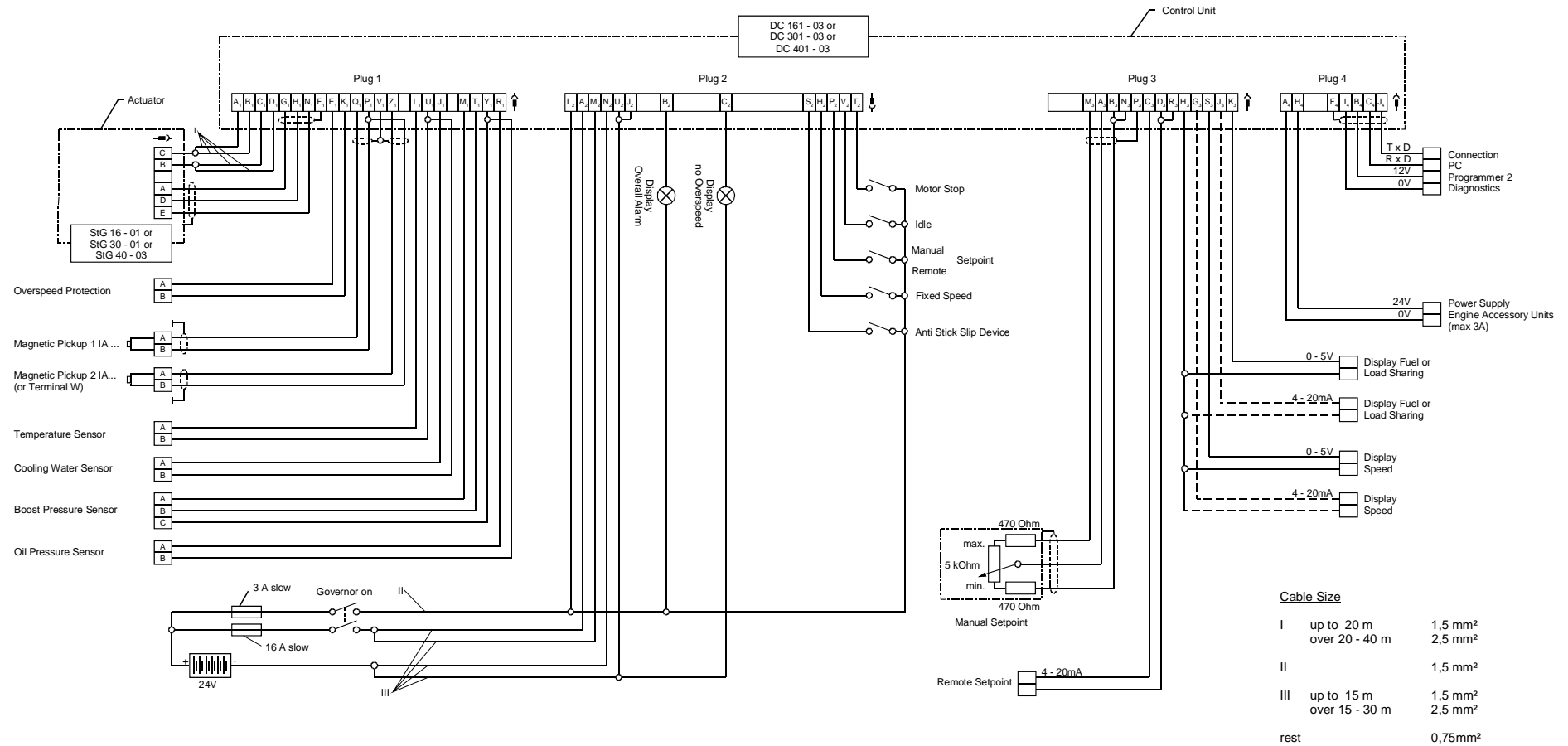

Figure 23: Connection for Locomotive Operation with Speed Setpoint via Current Signal

10.8 Example of Connection for Marine Operation with Master/Slave

(Twin operation: 2 engines on one shaft)

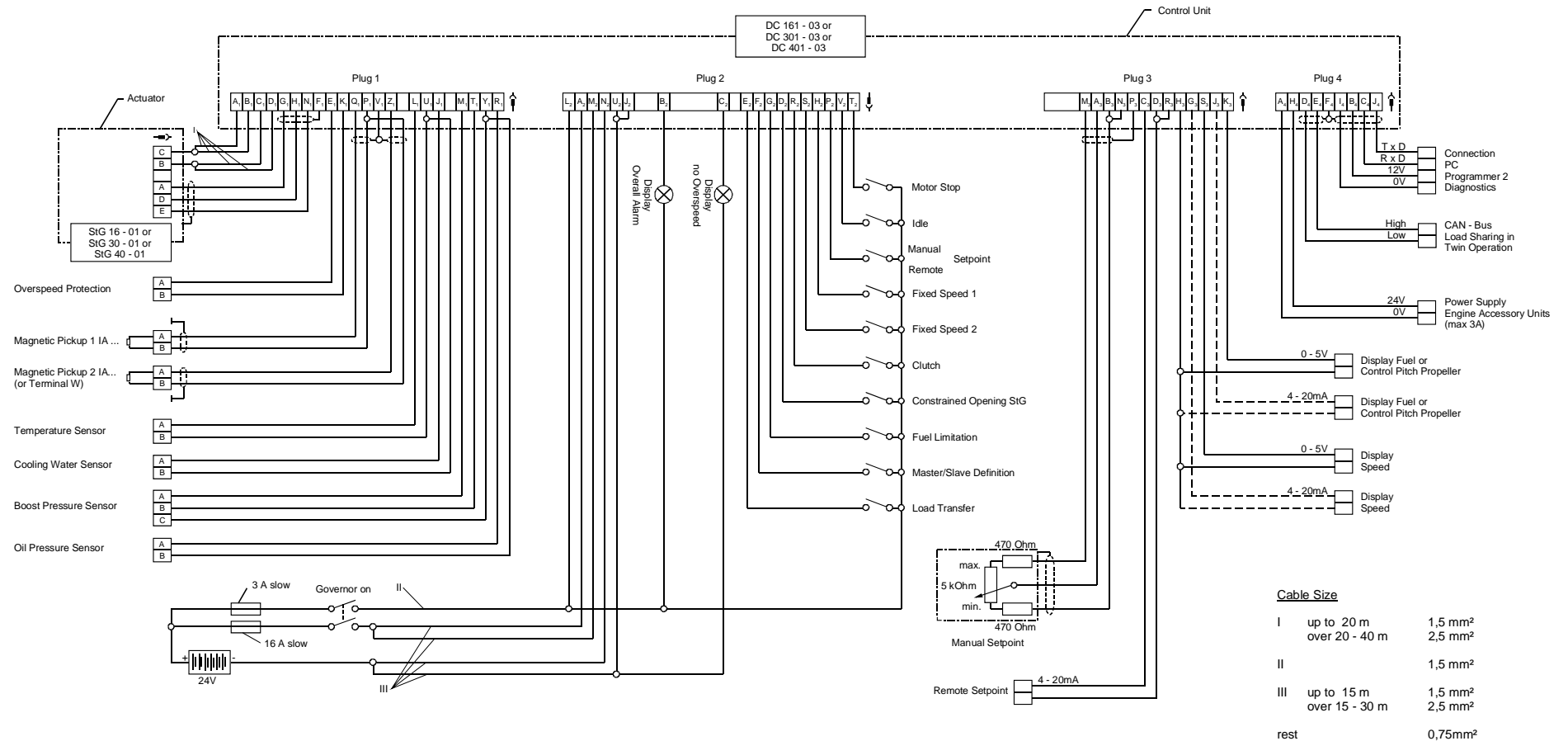

Figure 24: Connection for Marine Operation with Master/Slave

10.9 Example of Connection for Marine Operation in single Operation

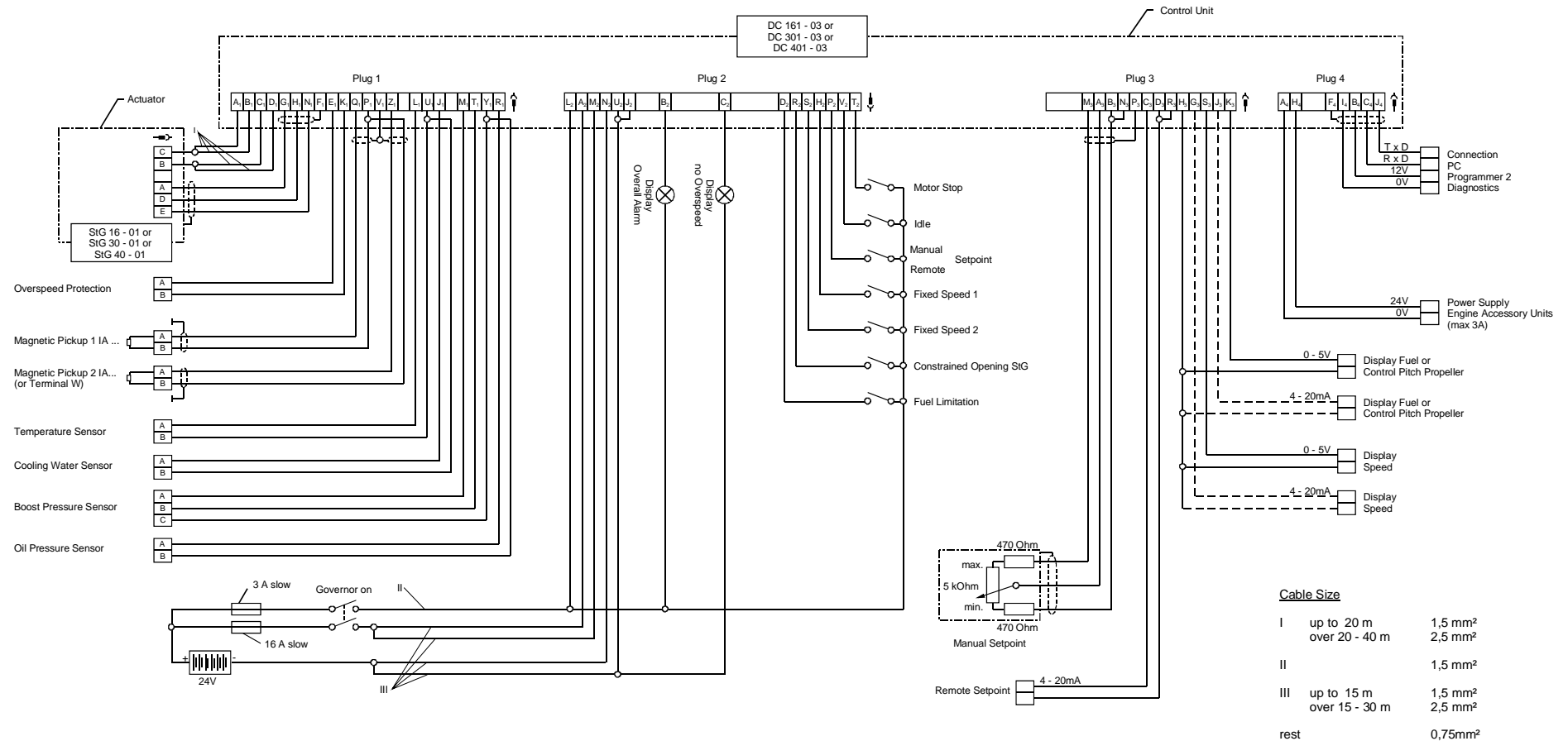

Figure 25: Example of Connection for Marine Operation in single Operation

11 Harness

11.1 Cable Lengths

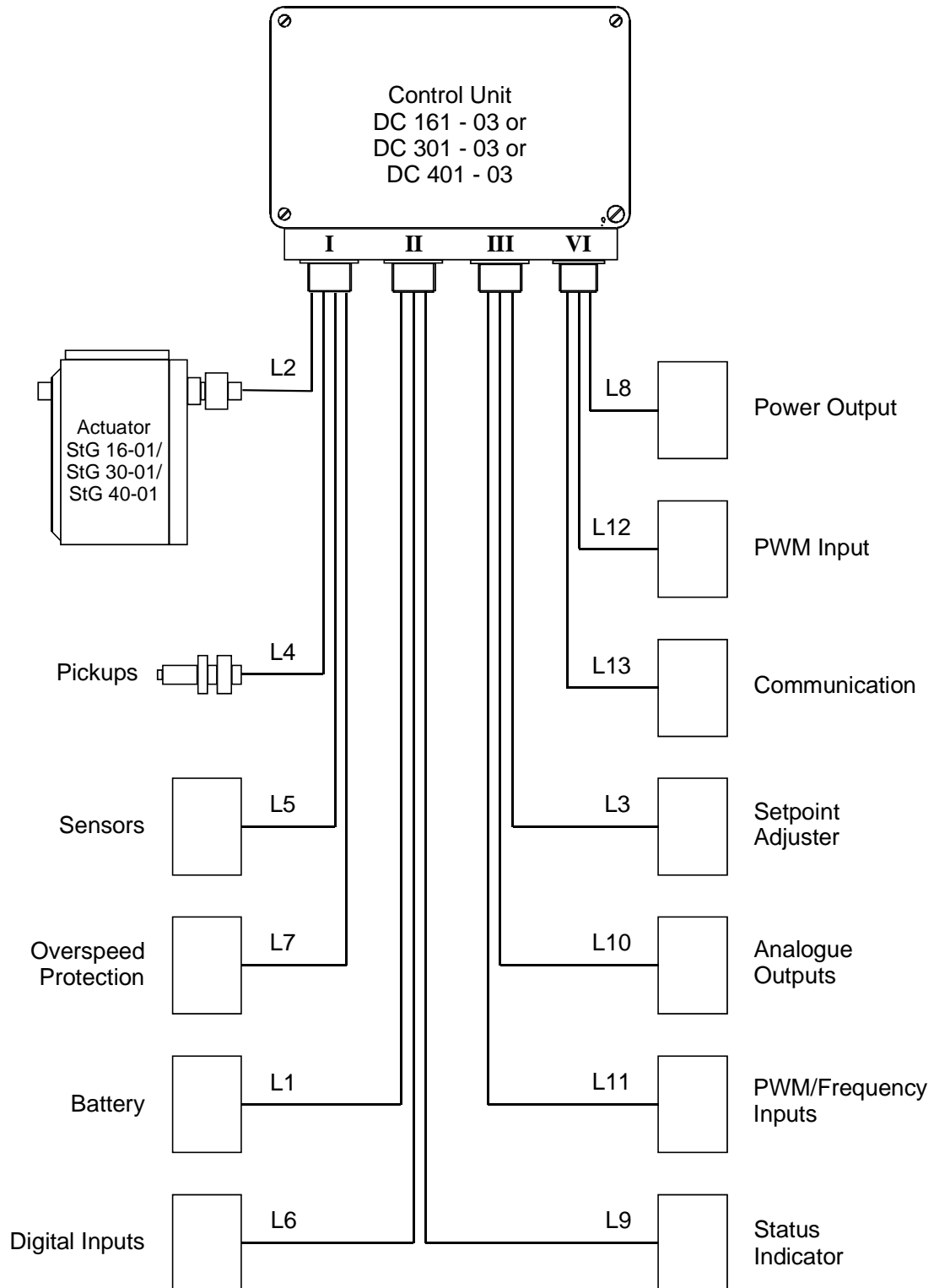

Figure 26: Harness with Cable Numbers

11.2 Plug Designations

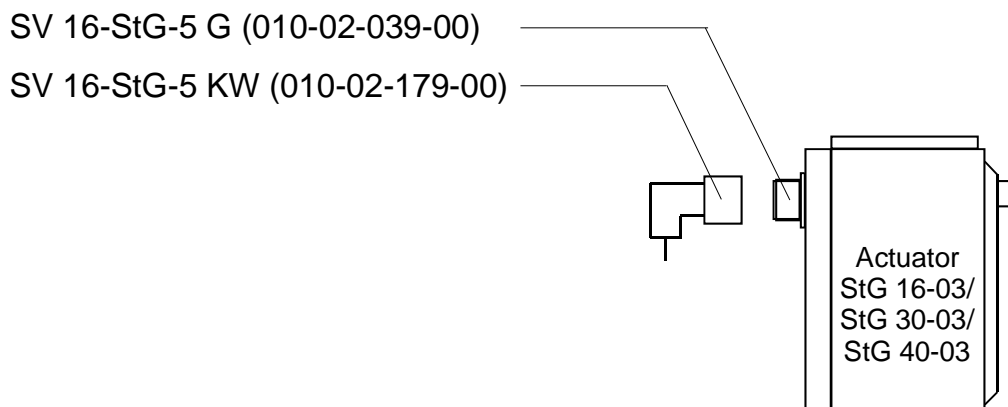
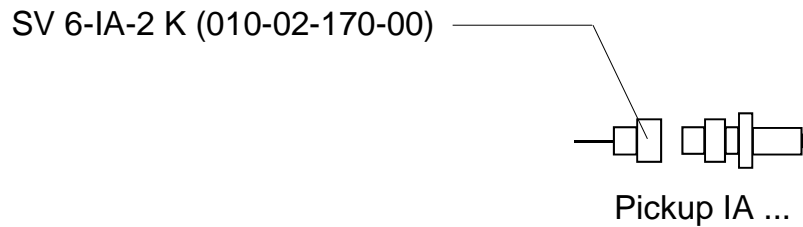
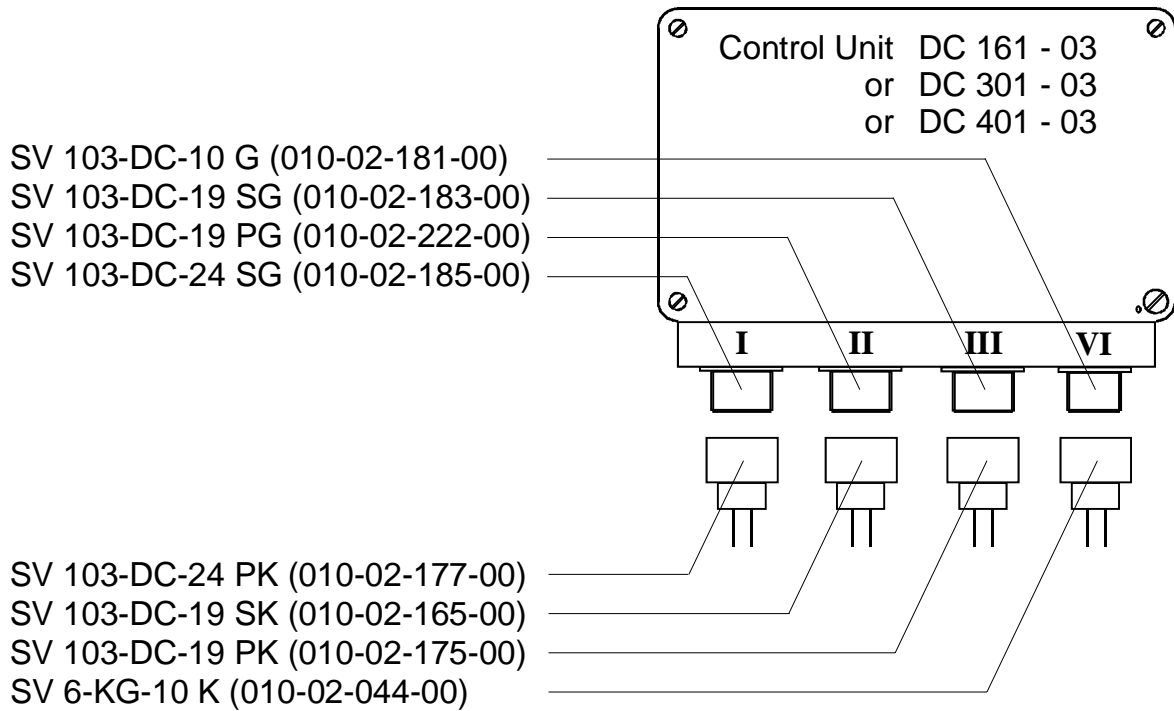

Figure 27: Plugs with Designation

12 Programming Possibilities

Programming the HEINZMANN Digital Governor can be performed according to the possibilities described below:

12.1 Programming by the Manufacturer

During final inspection by the manufacturer, the functionality of the governor is checked by means of a test program. If the operational data for the governor are available, the test program is executed using those data. On the engine, only the dynamic values and, if necessary, the actuator position limits and sensors have to be adjusted.

12.2 Programming with the Hand- Held Programmer 2

The entire programming can be performed using the Hand-Held Programmer 2. This handy device may be conveniently used for development and for serial adjustment as well as for service purposes.

12.3 Programming by PC

Programming can also be performed using the PC. In comparison with the hand-held programmer, this method offers advantages with respect to the possibilities of having characteristic curves readily displayed on the screen and easily varied; the same holds for the time diagrams when putting the governor into operation on the engine. Furthermore, the PC offers a better overview, as the PC program presents a menu structure and is able to continuously display several parameters at a time.

The PC program also permits to save and load governor data to and from diskettes.

12.4 Programming with User Masks

Principally, programming may be performed with the help of user masks that have been provided by HEINZMANN or may conveniently be created by the user himself. Within a user mask, only those parameters are accessible that are actually needed.

12.5 Transferring Data Sets

Once programming with respect to a specific engine type and its application has been completed, the data set can be stored (in the hand-held programmer or on diskette). For future cases of similar applications, the data set may be downloaded into the new governors.

12.6 Assembly Line End Programming

This method of programming is applied by the engine manufacturer during the final bench tests of the engine. On this occasion, the governor is programmed with regard to operation requirements and to ordering specifications.

13 Starting the Engine - Brief Instructions

13.1 Adjust clearance of magnetic pulse pickup.

13.2 Check program with respect to relevant parameters: number of teeth, speed, etc.

13.3 Set point potentiometer in mid-position:

P - Gain to 50

I - Stability to 0

D- Derivative to 0

If the dynamic values have already been determined for an installation, they can be programmed directly at this point.



Overspeed protection must be guaranteed!

Warning

13.4 Start engine and run it up to nominal speed using the set point potentiometer.

13.5 Increase gain (P-fraction) up to instability and reduce until stability is attained.

Increase stability (I-fraction) up to instability and reduce until stability is attained.

Increase derivative (D-fraction) up to instability and reduce until stability is attained.

With these values set, engine speed is to be disturbed briefly (e.g., by shortly pressing the stop switch), and the transient oscillations are to be observed.

13.6 Check over the entire speed range.

If for maximum and minimum speed other values than the programmed ones should result, this will be due to tolerances of the set point potentiometer. If the speed derivation is not acceptable, it will be necessary to measure the setpoint source.

13.7 Gain-correction (P-correction) for gas engines resp. for variable speed governors with larger speed ranges; adjust map if necessary.

13.8 Checking the remaining program items, e.g., starting fuel injection, ramp time, etc.



Note

The adjustment procedures as required for items 13.2 bis 13.8 and any further options of adjustment are in detail described in brochure DG 95110 - e.

14 Ordering Specifications

14.1 General

To know which informations we need, we have made a special order information for digital governors. It has the No. DG 96 012-d. This form has to be filled in and send to HEINZMANN together with the order.

14.2 Cable Length

It is of advantage to obtain the harness together with the governor.



Note

It is not possible to use all signals simultaneous because some inputs and outputs of the governor have various options depending on the application.

a) L1 = Control Unit - Power Supply

L 1.1	Control unit - power supplycm	5 x 1,50 mm ²
-------	-----------------------------	---------	--------------------------

b) L2 = Control Unit - Actuator

L 2.1	Control unit - actuator (feedback)cm	3 x 0,75 mm ² shielded
-------	------------------------------------	---------	-----------------------------------

L 2.2	Control unit - actuator (drive)cm	4 x 1,50 mm ²
-------	---------------------------------	---------	--------------------------

c) L3 = Control Unit - Setpoint Adjuster

L 3.1	Control unit - local setpointcm	3 x 0,75 mm ² shielded
-------	-------------------------------	---------	-----------------------------------

L 3.2	Control unit - manual setpointcm	2 x 0,75 mm ²
-------	--------------------------------	---------	--------------------------

L 3.3	Control unit - accessory unit 1cm	2 x 0,75 mm ² shielded
-------	---------------------------------	---------	-----------------------------------

L 3.4	Control unit - accessory unit 2cm	2 x 0,75 mm ² shielded
-------	---------------------------------	---------	-----------------------------------

d) L4 = Control Unit - Magnetic Pickup

L 4.1	Control unit - magnetic pickup 1cm	2 x 0,75 mm ² shielded
-------	----------------------------------	---------	-----------------------------------

L 4.2	Control unit - magnetic pickup 2cm	2 x 0,75 mm ² shielded
-------	----------------------------------	---------	-----------------------------------

e) L5 = Control Unit - Sensors

L 5.1	Control unit - boost pressure sensorcm	2 x 0,75 mm ²
L 5.2	Control unit - coolant temp. sensorcm	2 x 0,75 mm ²
L 5.3	Control unit - boost pressurecm	3 x 0,75 mm ²
L 5.4	Control unit - oil pressurecm	3 x 0,75 mm ²

f) L6 = Control Unit - Digital Inputs

L 6.1	Control unit - engine stopcm	1 x 0,75 mm ²
L 6.2	Control unit - switch 2cm	1 x 0,75 mm ²
L 6.3	Control unit - switch 3cm	1 x 0,75 mm ²
L 6.4	Control unit - switch 4cm	1 x 0,75 mm ²
L 6.5	Control unit - switch 5cm	1 x 0,75 mm ²
L 6.6	Control unit - switch 6cm	1 x 0,75 mm ²
L 6.7	Control unit - switch 7cm	1 x 0,75 mm ²
L 6.8	Control unit - switch 8cm	1 x 0,75 mm ²
L 6.9	Control unit - switch 9cm	1 x 0,75 mm ²
L 6.10	Control unit - switch 10cm	1 x 0,75 mm ²

g) L7 = Control Unit - Overspeed Protection

L 7	Control unit - overspeed protectioncm	2 x 0,75 mm ²
-----	-------------------------------------	---------	--------------------------

h) L8 = Control Unit – Controlled Current Output

L 7	Control unit – contr. current outputcm	2 x 0,75 mm ²
-----	--------------------------------------	---------	--------------------------

i) L9 = Control Unit - Status Indicator

L 9.1	Control unit - common alarmcm	2 x 0,75 mm ²
L 9.2	Control unit - overspeedcm	2 x 0,75 mm ²

j) L10 = Control Unit - Analogue Outputs

L 10.1	Control unit - display fuelcm	2 x 0,75 mm ²
L 10.2	Control unit - display speedcm	2 x 0,75 mm ²
L 10.3	Control unit - load sharingcm	2 x 0,75 mm ²
L 10.4	Control unit - pitch propeller controlcm	2 x 0,75 mm ²

k) L11 = Control Unit - Frequency Input

L 11	Control unit - tachocm	2 x 0,75 mm ²
------	----------------------	---------	--------------------------

l) L12 = Control Unit - PWM Input

L 12	Control unit - PWM inputcm	2 x 0,75 mm ²
------	--------------------------	---------	--------------------------

m) L13 = Communication

L 13	Control unit - PCcm	4 x 0,75 mm ² shielded
------	-------------------	---------	-----------------------------------

15 Figure List

Figure 1: Blockdiagram DG 16.1 - 03 up to DG 40.1 - 03	8
Figure 2: Clearance of Pickup.....	11
Figure 3: Magnetic Pickup	12
Figure 4: Temperature Sensor TS 01 - 28 - PT 1000	13
Figure 5: Oil Pressure Sensor	14
Figure 6: Boost Pressure Sensor with Plug	15
Figure 7: Boost Pressure Sensor with Housing.....	16
Figure 8: Potentiometer SW 01 - 1 - b	17
Figure 9: Potentiometer SW 02 - 10 - b	17
Figure 10: Control Unit DC 16.1 - 03 up to DC 40.1 - 03	20
Figure 11: Sectional Drawing of Actuator	21
Figure 12: Actuators StG 16 - 01, StG 30 -01 and StG 40 - 01	25
Figure 13: Linkage for Diesel Engines	27
Figure 14: Linkage for Gas Engines	28
Figure 15: Connection of separat Wire	29
Figure 16: Shield Connection without Plug	29
Figure 17: Shield Connection in the Plug	30
Figure 18: Correct Connection of Power Supply	31
Figure 19: Connection for Generator Set with digital Accessories.....	32
Figure 20: Connection for Generator Set with analogue Accessories	33
Figure 21: Connection for Vehicle Operation.....	34
Figure 22: Connection for Locomotive Operation with 16 Notches.....	35
Figure 23: Connection for Locomotive Operation with Speed Setpoint via Current Signal ...	36
Figure 24: Connection for Marine Operation with Master/Slave	37
Figure 25: Example of Connection for Marine Operation in single Operation	38
Figure 26: Harness with Cable Numbers	39
Figure 27: Plugs with Designation	40

16 Order Specifications for Manuals

There is no charge for our technical manuals ordered in reasonable quantities.

Order the necessary manuals on our speed governors from your nearest

[HEINZMANN location](#).

(Please click on “HEINZMANN location” to see the list of our subsidiaries and agents in the world).

Please include the following information:

- your name,
- the name and address of your company (you can simply include your business card),
- the address where you want the manuals sent (if different from above),
- the number(s) (as on front page bottom right) and title(s) of the desired manual(s),
- or the technical data of your HEINZMANN equipment,
- the quantity you want.

You can directly use the following fax-form for ordering one or several manuals.

Most of the manuals are available as Acrobat PDF-files, too. On request they can be send via e-mail.

We solicit comments about the content and the presentation of our publications. Please, send your comments to:

HEINZMANN GmbH & Co. KG

Service Department

Am Haselbach 1

D-79677 Schönau

Germany

Fax Reply

Order for HEINZMANN technical manuals

Fax-Hotline +49 7673 8208 194

Please send me the following manuals:

Quantity	No. of the manual	Title

Please send me your new sales documentation about

() the HEINZMANN Analogue Governors Application:

() the HEINZMANN Digital Governors Application:

() the HEINZMANN Gas Engine Equipment Application:

Company

Contact Person.....

Department

Address..... Country/Code/Town.....

Phone..... Fax.....

E-Mail.....

Activity.....

Date